

Technology Assessment and Application Guide for DynaCom™—A Single-Phase Voltage Sag Compensator

1011804

Technology Assessment and Application Guide for DynaCom™ – A Single-Phase Voltage Sag Compensator

1011804

Technical Update, October 2005

EPRI Project Manager

M Samotyj

DISCLAIMER OF WARRANTIES AND LIMITATION OF LIABILITIES

THIS DOCUMENT WAS PREPARED BY THE ORGANIZATION(S) NAMED BELOW AS AN ACCOUNT OF WORK SPONSORED OR COSPONSORED BY THE ELECTRIC POWER RESEARCH INSTITUTE, INC. (EPRI). NEITHER EPRI, ANY MEMBER OF EPRI, ANY COSPONSOR, THE ORGANIZATION(S) BELOW, NOR ANY PERSON ACTING ON BEHALF OF ANY OF THEM:

(A) MAKES ANY WARRANTY OR REPRESENTATION WHATSOEVER, EXPRESS OR IMPLIED, (I) WITH RESPECT TO THE USE OF ANY INFORMATION, APPARATUS, METHOD, PROCESS, OR SIMILAR ITEM DISCLOSED IN THIS DOCUMENT, INCLUDING MERCHANTABILITY AND FITNESS FOR A PARTICULAR PURPOSE, OR (II) THAT SUCH USE DOES NOT INFRINGE ON OR INTERFERE WITH PRIVATELY OWNED RIGHTS, INCLUDING ANY PARTY'S INTELLECTUAL PROPERTY, OR (III) THAT THIS DOCUMENT IS SUITABLE TO ANY PARTICULAR USER'S CIRCUMSTANCE; OR

(B) ASSUMES RESPONSIBILITY FOR ANY DAMAGES OR OTHER LIABILITY WHATSOEVER (INCLUDING ANY CONSEQUENTIAL DAMAGES, EVEN IF EPRI OR ANY EPRI REPRESENTATIVE HAS BEEN ADVISED OF THE POSSIBILITY OF SUCH DAMAGES) RESULTING FROM YOUR SELECTION OR USE OF THIS DOCUMENT OR ANY INFORMATION, APPARATUS, METHOD, PROCESS, OR SIMILAR ITEM DISCLOSED IN THIS DOCUMENT.

ORGANIZATION THAT PREPARED THIS DOCUMENT

EPRI Solutions, Inc.

This is an EPRI Technical Update report. A Technical Update report is intended as an informal report of continuing research, a meeting, or a topical study. It is not a final EPRI technical report.

ORDERING INFORMATION

Requests for copies of this report should be directed to EPRI Orders and Conferences, 1355 Willow Way, Suite 278, Concord, CA 94520. Toll-free number: 800.313.3774, press 2, or internally x5379; voice: 925.609.9169; fax: 925.609.1310.

Electric Power Research Institute and EPRI are registered service marks of the Electric Power Research Institute, Inc.

Copyright © 2005 Electric Power Research Institute, Inc. All rights reserved.

CITATIONS

This document was prepared by

EPRI Solutions, Inc.
942 Corridor Park Blvd.
Knoxville, Tennessee 37932

Principal Investigator
K. Gomatam

This document describes research sponsored by the Electric Power Research Institute (EPRI).

The publication is a corporate document that should be cited in the literature in the following manner:

Technology Assessment and Application Guide for DynaCom™ – A Single-Phase Voltage Sag Compensator, EPRI, Palo Alto, CA: 2005. 1011804.

ABSTRACT

The needs for higher production rates, lower production costs, and increased reliability in today's highly competitive markets are fueling the need for increased automation and control of industrial processes. Most industrial equipment is designed to operate when the electrical supply is "clean," that is, when voltage sags, momentary interruptions, voltage unbalance, single-phasing and other electrical disturbances are not part of the power supply. However, some variation in power quality is normal to power system operation. Electrical disturbances can cause electronic and electromechanical devices to trip and shut down.

A number of power conditioning devices are now used to mitigate the effect of power system disturbances on industrial equipment. The effectiveness of such equipment must be tested to understand their capabilities and limitations in protecting various types of loads.

This technical update describes the operation, features, and test results of DynaCom™ SS291, a single-phase voltage sag compensator designed to mitigate the effects of voltage sags on single-phase loads.

CONTENTS

1 INTRODUCTION.....	1-1
Problems Associated With Power Quality Disturbances	1-1
Sag-Mitigation Device	1-1
Operation of DynaCom™	1-2
2 DYNACOM™ CHARACTERIZATION TESTS	2-1
Test Description	2-1
Significance of the Characterization Tests	2-1
Objectives.....	2-1
Procedure	2-1
Results	2-2
Voltage Sag and Swell Test Results.....	2-2
Repetitive Voltage Sag Test Results	2-4
Response Time	2-5
Step Load Response	2-6
Steady-State Output Voltage Regulation	2-7
SEMI F47 Standard Compliance Test Results	2-8
3 APPLICATION OF THE DYNACOM	3-1
Knowledge of Equipment Versus Cost of Solution.....	3-1
Typical DynaCom™ Application.....	3-1
Application Issues	3-2
Start-Up Issues.....	3-2
Protection and Overloading Issues.....	3-2
Size and Weight Constraints	3-2
Maintenance Issues.....	3-2
4 SUMMARY.....	4-1

1

INTRODUCTION

Problems Associated With Power Quality Disturbances

While many consider sustained power interruptions to be the most serious power quality events encountered by industrial users of electric power, they are not the only events that can cause problems. Momentary breaker and recloser operations before lockout can have just as great an effect on sensitive end-use equipment as the actual lockout itself. Semiconductor-manufacturing plants, for example, are especially vulnerable to power quality events. The total time required to produce a semiconductor chip may be as long as 30 days, with numerous critical processes involved. The chip may be ruined at any time during this process if a voltage sag or momentary interruption causes a sensitive machine to trip or causes an abnormal operation. Other industries that are sensitive to voltage sags and momentary interruptions include pharmaceutical, plastics, rubber, paper, textiles, glass, automobile, and steel manufacturing plants.

Some of the components most sensitive to voltage disturbances are the contactors and relays that control the machinery. Relays can drop out within 5 to 20 milliseconds after the start of voltage sags as small as 75% of nominal voltage. These small devices are often responsible for shutting down the entire process. Recovering from such events can be time-consuming and expensive to the electric power customer.

Sag-Mitigation Device

This technical update documents the operation, features, and applications of the DynaCom™ SS291, a single-phase voltage sag compensator designed to mitigate the effects of voltage sags on single-phase loads. The key features of the DynaCom™ as specified by the manufacturer are as follows:

- The DynaCom™ provides protection against voltage sags to as low as 40% nominal voltage for up to 1 second with full rated loading of 1.5 kVA.
- Low response time of < 2 milliseconds and a transfer level of 90% remaining voltage.
- Battery free operation. Ultracapacitors used for energy storage ensure less maintenance and smaller footprint than batteries.
- The DynaCom™ provides LED indication on the front-panel for ON and OFF status. In addition, 'charging' or 'system diagnostic' is indicated by the RED color of the LED. A RESET button is also provided on the front-panel.
- According to the manufacturer, the single-phase DynaCom™ is available in nominal current capacities of 12.5 A, 25 A and 50 A. Each of the above models is available with nominal voltages of (input/output) 120V, 220V, 240V, 277 V and 346V.
- The DynaCom™ meets international standards (CE, CSA and UL approved. Exceeds SEMI F47).

- Environmentally friendly (no battery disposal).

Operation of DynaCom™

The DynaCom™ has two modes of operation – Normal operating mode and compensation mode. In the normal operating mode the thyristors are ON and the DynaCom™ allows the utility voltage to pass to the load. According to the manufacturer, the DynaCom™ has an overall efficiency of more than 98% in normal operating mode.

A simple block diagram of the operating modes of the DynaCom™ is shown in Figure 1-1. The control circuit in the DynaCom™ has a digital signal processor (DSP) that continuously monitors the input supply voltage. When the controller detects a voltage sag event on the input voltage, it switches to compensation mode.

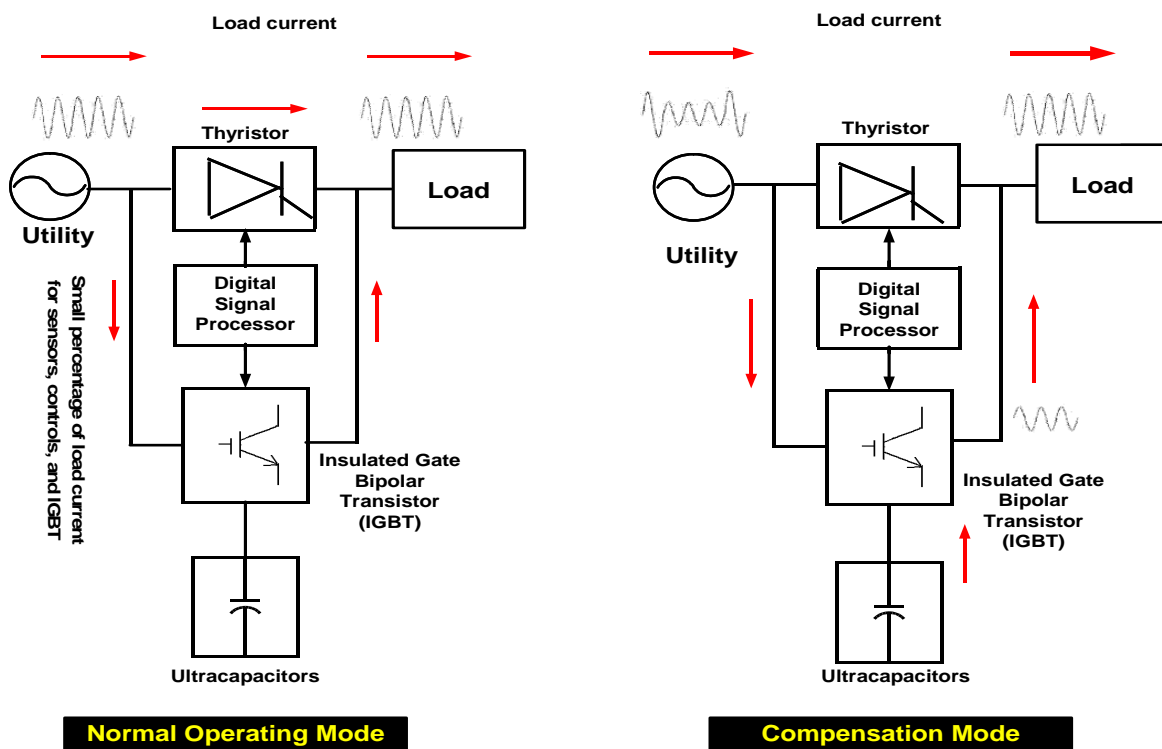

Figure 1-1
Operating Modes of the DynaCom™
 Source: Meiden Power Solutions (Singapore) PTE LTD

In compensation mode, the DynaCom™ injects “compensation” voltage to restore the voltage to as close to normal as possible. The DSP-based controller senses the input voltage to the DynaCom™ and captures the waveform. If the difference in the measured voltage and the set level is more than a certain setpoint, the DynaCom™ assumes that a voltage sag is occurring. It then turns off the thyristors and switches on the IGBTs to provide a pulse-width modulated (PWM) compensation voltage. The IGBTs draw DC power from the ultracapacitor bank, convert it to AC, and series-inject it to restore normal voltage to the output. By default, the transfer level (or compensation level) is 90%. This means that the DynaCom™ switches into compensation mode for voltage sags or events with 90% nominal voltage or less remaining.

The manufacturer's specification mentions that this transfer level can be changed as per application requirements. The tests described below were conducted on the DynaCom™ at the default transfer level of 90%. The system block diagram is shown in Figure 1-2.

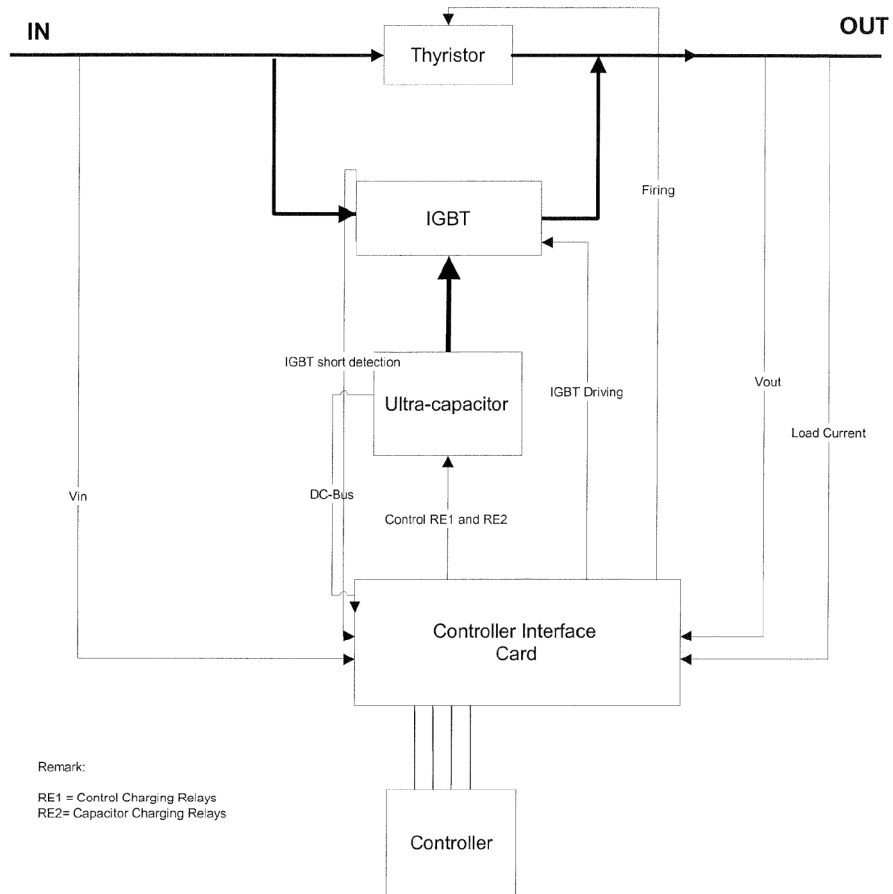

Figure 2

Figure 1-2
System Block Diagram of the DynaCom™

2

DYNACOM™ CHARACTERIZATION TESTS

This section covers the characterization tests conducted on the DynaCom™ SS291 unit at the EPRI Solutions test facility. The unit under test was rated at 1.5 kVA, 120 V, single-phase. The characterization tests included:

- Voltage sag and swell tests
- Repetitive Voltage sag tests
- Response time
- Step load response
- Steady-state output voltage regulation
- SEMI F47 standard compliance test

A 100A portable sag generator was employed to conduct these tests. The following sections describe the tests, procedures, and the results.

Test Description

Significance of the Characterization Tests

The characterization tests gauge the response of the device to several common disturbances that occur in typical manufacturing plants. The characterization tests verify the ability of the device to handle voltage variations in a plant. Additionally, the characterization tests provide information that may help the customer to evaluate the suitability of this device in a particular facility.

Objectives

The characterization tests have several objectives:

1. To verify that the performance of the device meets the manufacturer's specifications.
2. To measure the response time required by the DynaCom™ to detect and correct voltage sags.
3. To determine whether the DynaCom™ can protect and handle sensitive and non-linear loads at the preset transfer level.
4. To determine the sag protection envelope of the DynaCom™ with particular load types like programmable logic controllers (PLCs) and small motor drives.
5. To uncover any application issues that could be of value to the end user.

Procedure

The test setup for the characterization tests conducted on the DynaCom™ is shown in Figure 2-1. The Variac connected to the utility supply is used to maintain the input voltage to the

DynaCom™ at 120 V. The portable sag generator enables investigators to apply voltage sags (and swells) for the desired depth and desired number of cycles. The output of the DynaCom™ is connected to different types of loads as per the test requirement.

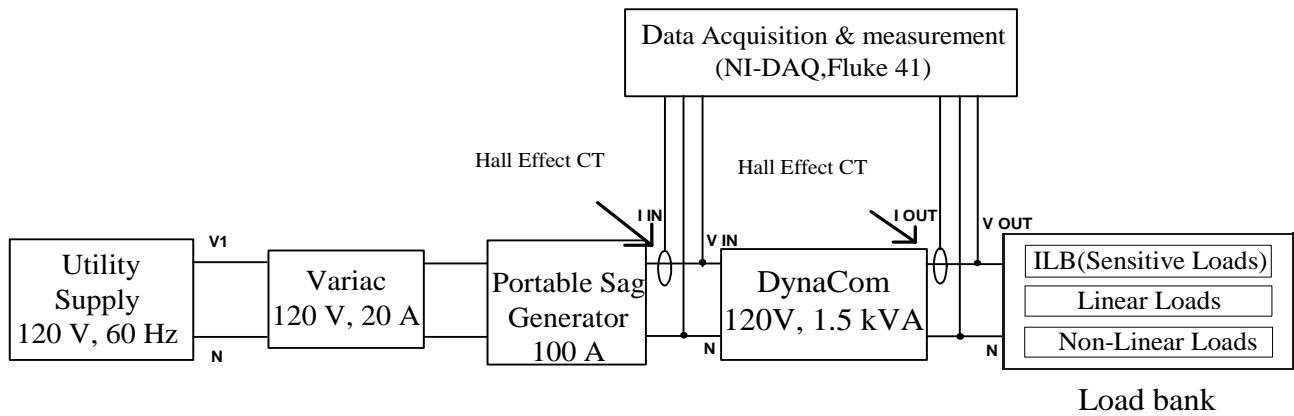

Figure 2-1
DynaCom™ Voltage-Sag Test Setup

The industrial load bank (ILB) is a permanent fixture that allows engineers to demonstrate the voltage-sag susceptibility of typical control components such as PLCs, relays, contactors, and power supplies and to characterize the ability of single-phase power conditioners to improve immunity of these loads. It is used to create a real-life loading environment for power-conditioning devices that will be used to demonstrate protection and immunity improvements. The ILB serves as an excellent test platform for evaluating the effectiveness of various power quality mitigation devices. More information about the ILB can be found in PQTN Brief 44¹ and 45².

The DynaCom™ was initially loaded to 25% of its rated capacity. The portable sag generator was used to apply voltage sags of various magnitudes and durations. A similar procedure was followed for 50%, 75% and 100% loading, with otherwise identical test conditions. The input and the output of the DynaCom™ were monitored and recorded for analysis.

Results

Voltage Sag and Swell Test Results

Momentary reductions in line voltage lasting several cycles or longer may occur during power system faults and when large loads are switched on. Voltage sags are one of the most common and costly power quality issues in manufacturing environments. When voltage sags are severe enough to interrupt a manufacturing process, the common results are downtime, product waste,

¹ PQTN Brief No. 44, “The Effects of Point-on-Wave on Low-Voltage Tolerance of Industrial Process Devices,” EPRI PEAC Corporation, June 1998.

² PQTN Brief No. 45, “The Effects of Phase Shift on Low-Voltage Tolerance of Industrial Process Devices,” EPRI PEAC Corporation, June 1998.

and a lengthy cleanup. Likewise, a swell, or momentary increase in line voltage lasting several cycles can cause certain electronic equipment to shut down. Voltage swells can occur during power system faults or on secondary circuits in ungrounded systems. Figure 2-2 and Figure 2-3 show the input voltage and output voltages during voltage sags and swells.

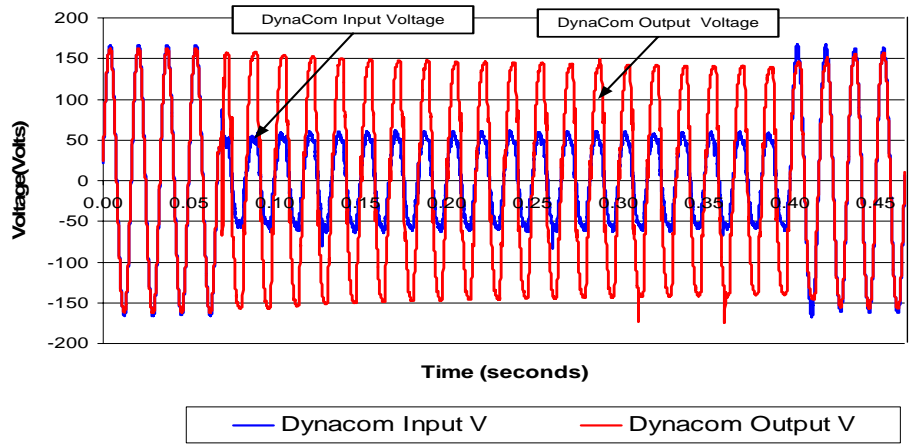

Figure 2-2
DynacomTM Input and Output Voltage Waveforms during a Voltage Sag Event of 60% Nominal Voltage Remaining for 20 Cycles at 60 Hz, at 100% Loading

Figure 2-2 shows the input and output voltages for the DynacomTM during a voltage sag event with 60% of the nominal voltage remaining. The voltage sag lasted for about 333 milliseconds (20 cycles at 60 Hz). The load was protected during this event, and did not trip.

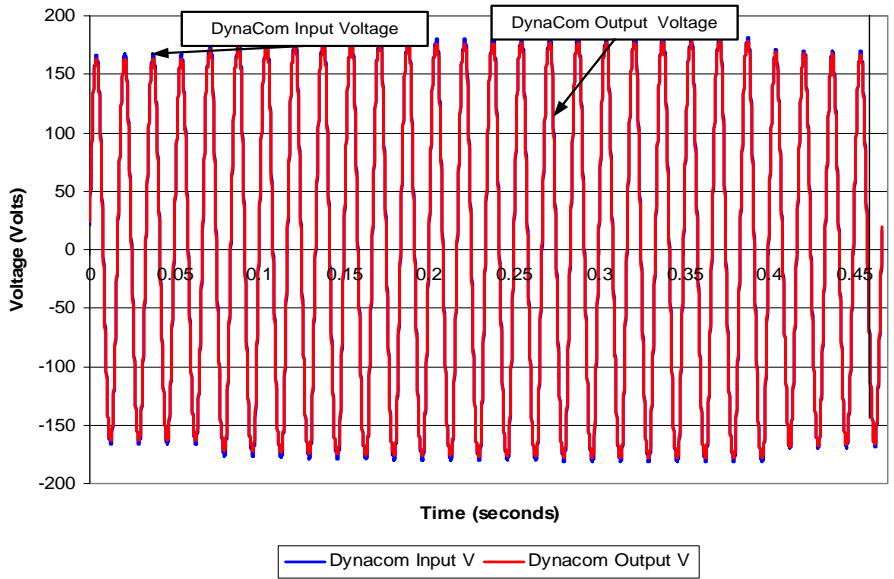

Figure 2-3

Dynacom™ Input and Output Voltage Waveforms During a Voltage Swell Event with 115% Nominal Voltage for 20 Cycles, at 100% Loading

Figure 2-3 shows the input and output voltages for the Dynacom™ during a voltage swell event with 115% nominal voltage. The voltage swell lasted for about 333 milliseconds (20 cycles at 60 Hz). It can be seen that the Dynacom™ does not regulate the output voltage during voltage swell events.

The results of the voltage sag testing conducted on the Dynacom™ in the compensating mode are summarized in the ride through curve shown in Figure 2-4. Curve A is the standard SEMIF47 curve. Curve B is the sag-ride through curve for a sensitive PLC load without Dynacom™. Certain PLCs can trip for voltage sags of 80% and less for 1 to 2 cycles. Curve C is the sag-ride through curve for the same PLC when powered by the Dynacom™. It is important to note that the Dynacom™ was loaded to 100% of capacity during the test. The Dynacom™ greatly enhances the PLC ride-through curve.

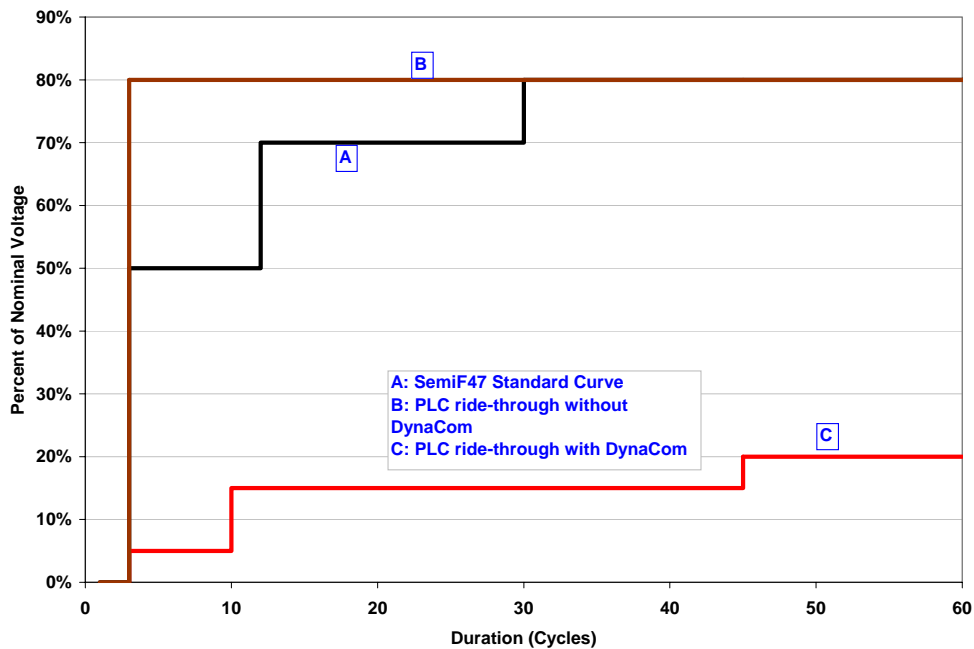

Figure 2-4
Sag Ride-Through Curve for a Typical Sensitive Load (PLC) Without and With Dynacom™ in the Compensating Mode at 100% Loading

Repetitive Voltage Sag Test Results

Automatic reclosers installed on distribution circuits protect the utility's equipment while providing the convenience of automatically restoring power after a fault. If a fault causes the recloser to open, it will attempt to reapply power after a preset time delay. In some cases, a fault will clear itself and power will be restored. If not, the recloser will typically make three to four attempts before "locking out" and requiring manual intervention. These repeated operations are often seen as successive voltage sags by customers on adjacent feeders.

The DynaCom™ was exposed to repetitive 6 cycle voltage sags down to 60% of nominal voltage for a period of 1 minute. The test involved a total of about twenty successive sags separated by an interval of about 3 seconds. A similar test was performed with 40% nominal voltage remaining. Both the tests showed satisfactory performance by the Dynacom™ and the loads were protected during repetitive sags. Figure 2-5 shows a typical response of the DynaCom™ during this test regimen. Note that the output voltage regulation remains close to the expected waveform, even after repetitive sag events.

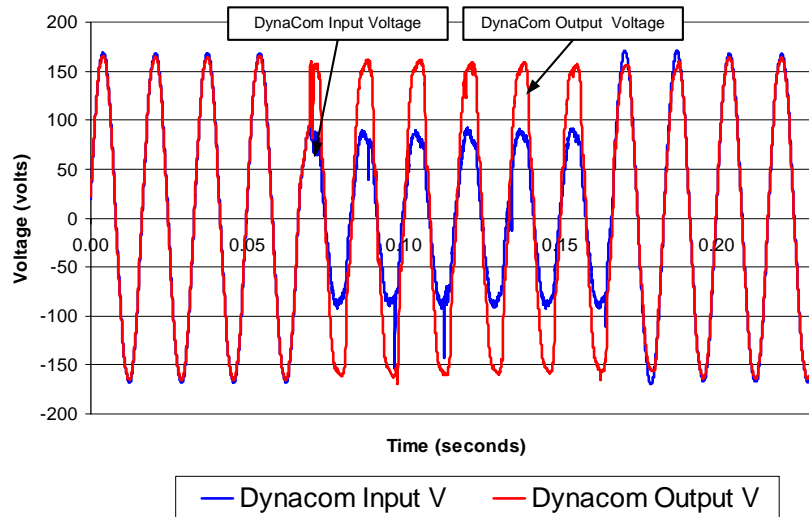

Figure 2-5
Dynacom™ Input and Output Voltage Waveforms at the End of a Sag Sequence Each With 60% Voltage Remaining for 6 Cycles at 60 Hz, Applied Repetitively for Twenty Successive Times

Response Time

The response time of the DynaCom™ is the time between the beginning of the sag event and the initiation of compensation voltage in response. This is an important issue for standby-type power conditioners, since some sensitive loads can trip before the transfer is complete (less than one cycle for some loads). The manufacturer has defined a response time and a transient time the sum of which is less than 5 milliseconds. The measured response and transient time as shown in Figure 2-6 is 3.40 milliseconds which is within the specification. The response time was measured with 100% loading on the DynaCom™.

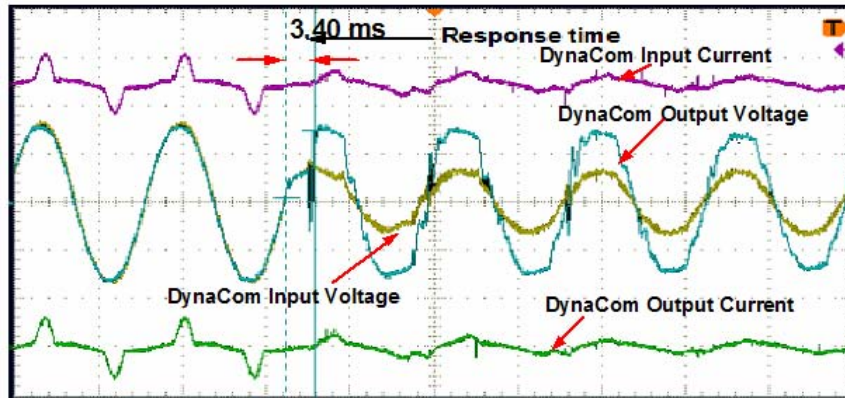

Figure 2-6
Response Time Plus Transient Time of the DynaCom™ with the New Firmware

Step Load Response

Inductive loads such as motors must often be supported by power conditioning equipment in order to produce consistent performance during voltage variations. However, not all types of power conditioners can supply the large inrush current drawn by inductive loads when they first start up. The starting current for an induction motor may be 6 to 7 times the nominal current draw.

The objective of this test was to find out if the DynaCom™ could protect loads during a step load variation. The DynaCom™ unit was tested with the new firmware provided by the manufacturer. In order to evaluate the step load response in detail, a load bank of power factor corrected power supplies was used to effect a step load change from approximately 25% to approximately 100%.

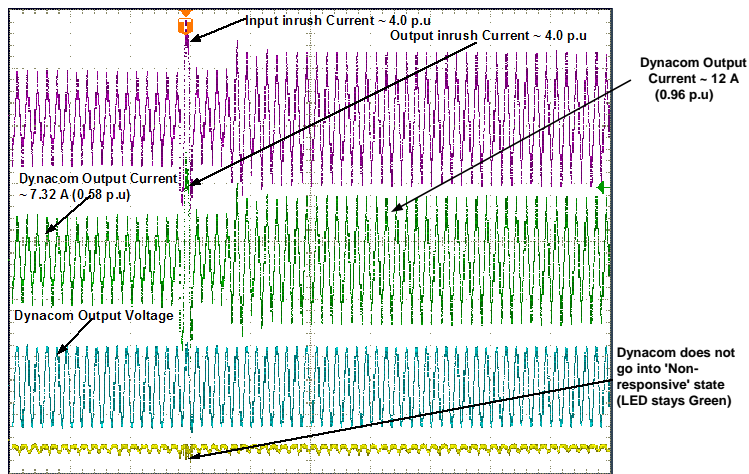

Figure 2-7
Response of the DynaCom™ to a Step Load Change From 0.58 p.u to 0.96 p.u with a Linear Load that Causes Low (4.0 p.u) Inrush Current. (Full Load Current of 12.5 A is Assumed as the Base for p.u Calculation)

Figure 2-7 shows the response of the DynaCom™ to a step load change with a linear load consisting of power factor compensated computer power supplies. The DynaCom™ was loaded to 7.32 A (0.58 p.u assuming full load current of 12.5 A as the base), with the industrial load bank. The linear load was switched ON and the total load on the DynaCom™ was about 12.0 A (0.96 p.u) The linear load draws a significant amount of inrush current (4.0 p.u), well within the manufacturer’s specification of 5 p.u. In the case when loads have inrush current more than the specification of 5 p.u the DynaCom™ goes into a ‘non-responsive’ state during which the DynaCom™ unit allows the voltage from the utility to pass to the load without any compensation. Care should be taken to make sure the load will not exceed this specification.

Steady-State Output Voltage Regulation

The steady-state output voltage regulation was evaluated by performing steady-state under-voltage and steady-state over-voltage tests on the DynaCom™. The objective of these tests was to find out if the DynaCom™ can maintain the output voltage if the utility supply has under-voltage or over-voltage for extended durations. The DynaCom™ unit under test was subjected to over-voltages of 105%, 110% and 120%. The under-voltage test was done by reducing the nominal input voltage from 100% through 70% in steps of 5%. Figure 2-8 below shows the steady-state output voltage regulation of the device. It can be seen that the output voltage is very well regulated.

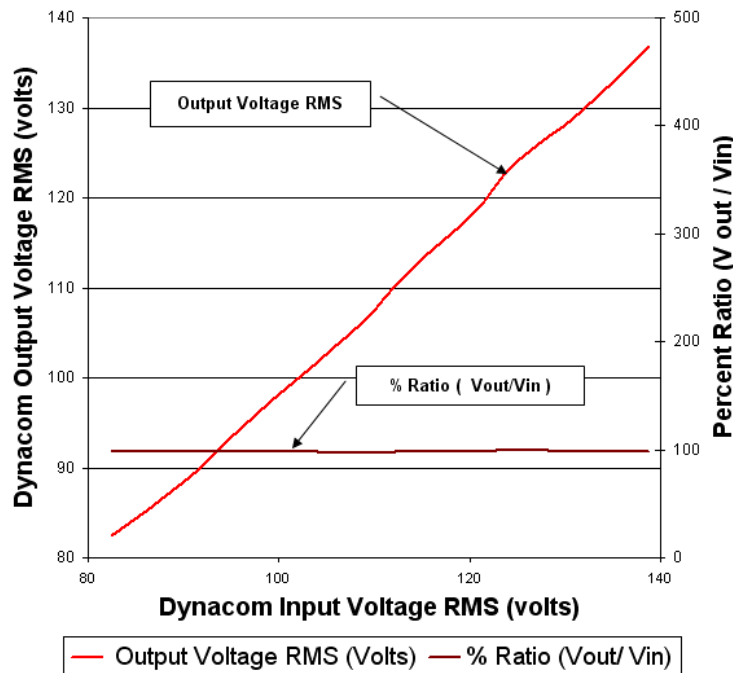

Figure 2-8
Steady State Output Voltage Regulation Capabilities of the Dynacom™

SEMI F47 Standard Compliance Test Results

The results obtained from the tests conducted at EPRI Solutions’ laboratory indicate that the DynaCom™ is capable of mitigating voltage sags effectively and is compliant with the SEMI F47 standard. Figure 2-9 shows the sag-handling capabilities of the DynaCom™ unit at full-load conditions. Curve A shows the SEMI F47 ride-through curve. Any voltage sag occurring above this curve should not affect the operation of a semiconductor tool. Any sag that falls below that curve is known to affect the operation of a tool. Use of the DynaCom™ clearly improved the ride-through for sensitive loads, meeting the SEMI F47 standard.

Curve B shows the points that represent the ride-through curve or the voltage tolerance curve at 120Vac for the DynaCom™ at full load conditions. The DynaCom™ was tested at points below the SEMI F47 curve to fully characterize the components. These points (1s at 20%, 0.75s at 15%, 0.16s at 5%, and 0.08s at 0%) are representative of sag events for which the DynaCom™ was able to restore the output voltage to close to the nominal value.

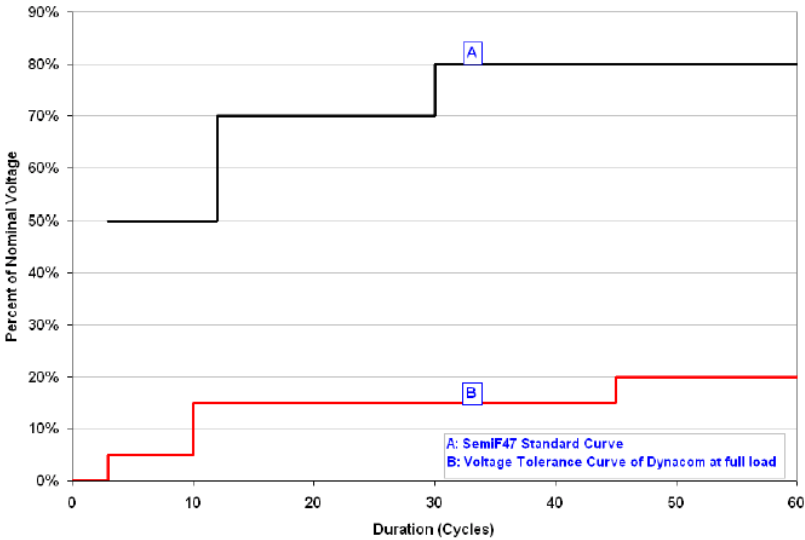

Figure 2-9
Ride-Through Curves for SEMI F47 and Sensitive Loads Protected by a DynaCom™

3

APPLICATION OF THE DYNACOM

Knowledge of Equipment Versus Cost of Solution

Momentary voltage variations are the most common power quality problems that affect industrial customers. There are various causes for voltage sags, which include temporary loss of supply, short circuits, load switching, and power swings. These voltage variations can lead to many problems, including:

- Contactor dropout
- Trips on variable-speed drives
- PLC dropout
- Abnormal operation of protective relays

Any of these events can cause an unplanned process shutdown. The prevention of such process shutdowns due to minor voltage variations can save industries significant amounts of money. This can be achieved by the use of ride-through devices, which protect the sensitive loads against momentary voltage fluctuations. The simplest approach to providing sag protection is to provide utility-level solutions; but the relative cost of such solutions is on the order of millions of dollars. Protection can be achieved for much less inside the plant at the control level, but this requires more knowledge of the process and the equipment. Smaller, less expensive power conditioners can be applied if the process is well understood. Studies of process equipment can lead to a situation in which a DynaCom™ could be a viable option.

Typical DynaCom™ Application

A DynaCom™ is a single-phase power quality mitigation device used to protect the critical process equipment from voltage disturbances. It is available in a wide range of sizes to support small and medium loads in the 1 kVA to 17.2 kVA range. A DynaCom™ can be used in process-level protection as well as system-level protection, depending on the nature of the problem in the facility. In addition, DynaComs comply with the SEMI F47 standard used by the semiconductor industry to ensure equipment ride-through. Some of the plants in which DynaComs can find good applications are semiconductor fabrication and cutting facilities, crystal growing facilities, newspaper plants, bottling plants, plastic extrusion plants, PVC pipe manufacturing plants, and automotive plants. Some of the typical devices that are protected by the DynaCom™ are small AC/DC drives, lighting devices, contactors, and PLCs.

Application Issues

The sections below describe the issues that should be considered by the customer before purchasing a DynaCom™ for a specific application. In some cases, there may be other devices that are better suited to the application, based on performance characteristics and customer needs. The following are some of the key application issues associated with this device.

Start-Up Issues

The DynaCom™ unit under test is rated for 1.5 kVA, 120V with maximum current of 12.5A. One of the challenges encountered during the testing procedure was that the initial start-up required up to 45 minutes for the ultracapacitors in the unit to charge to full capacity. After small duration interruptions (3 cycles at 60 Hz) for which the DynaCom is designed to compensate , the unit takes about 30 seconds to charge the ultracapacitors and is ready for compensation. During the start up period, the system can provide partial compensation.

Protection and Overloading Issues

The DynaCom™ comes with over-current, over-voltage, thyristor fault and IGBT fault protection. Induction motor loads comparable to the size of the Dynacom™ could cause large inrush currents, which might activate the over-current protection. During a fault condition the DynaCom™ goes into the diagnostic mode. The diagnostic mode could last for about 30 seconds or less, during which the loads might not be protected. After the fault has been cleared, the DynaCom™ does a system check and becomes operational again (Green display of the LED). Loads with high inrush current could cause this type of fault due to over current. Users should make sure that the loads connected to the DynaCom™ do not exceed the specification of load inrush current . Over-voltage on the input side up to 115% of nominal voltage did not have an effect on the normal operation of the DynaCom™. No tests were performed over 115%.

Size and Weight Constraints

The SS291 single phase DynaCom™ is portable and could be tower mounted or wall mounted. The actual dimensions of the DynaCom™ are 400 mm (W) x 250 mm (D) x 500 mm (H) and the weight of the DynaCom™ is approximately 45 lbs. Compared to some of the commercially available power conditioners in its class and capacity, the DynaCom™ is larger in size. Space requirements should be considered when several DynaComs are required to be installed for a specific application, in an industrial plant.

Maintenance Issues

The SS291 single phase DynaCom™ unit can be obtained with an auto bypass panel. The auto bypass panel has a make-before-break, 3-position, key-lockable rotary cam switch that operates the bypass contactor to keep the loads powered. This enables the DynaCom™ to be electrically isolated from the circuit for routine and preventive maintenance without powering down the loads. An important maintenance advantage for the DynaCom™ is the use of ultracapacitors instead of conventional batteries. These devices require very little routine maintenance and have longer expected life than alternatives such as batteries.

4

SUMMARY

The DynaCom™ that was tested is a single-phase voltage-sag-mitigation device. It comes in different ratings from 1 kVA up to 17.2 kVA, single-phase, 2-wire type. Three-phase DynaCom™ devices are also available for large applications. The SS291 single phase DynaCom™ unit complies with the SEMI F47 standard, the stringent semiconductor industry ride-through standard.

Its typical applications include but are not limited to HID lamps, small motors, programmable logic controllers (PLCs), and various industrial contactors and relays. Overall the DynaCom™ could be a good choice for customers that are looking for a low-maintenance, single-phase power quality mitigation device to protect their processes from voltage sags.

Export Control Restrictions

Access to and use of EPRI Intellectual Property is granted with the specific understanding and requirement that responsibility for ensuring full compliance with all applicable U.S. and foreign export laws and regulations is being undertaken by you and your company. This includes an obligation to ensure that any individual receiving access hereunder who is not a U.S. citizen or permanent U.S. resident is permitted access under applicable U.S. and foreign export laws and regulations. In the event you are uncertain whether you or your company may lawfully obtain access to this EPRI Intellectual Property, you acknowledge that it is your obligation to consult with your company's legal counsel to determine whether this access is lawful. Although EPRI may make available on a case-by-case basis an informal assessment of the applicable U.S. export classification for specific EPRI Intellectual Property, you and your company acknowledge that this assessment is solely for informational purposes and not for reliance purposes. You and your company acknowledge that it is still the obligation of you and your company to make your own assessment of the applicable U.S. export classification and ensure compliance accordingly. You and your company understand and acknowledge your obligations to make a prompt report to EPRI and the appropriate authorities regarding any access to or use of EPRI Intellectual Property hereunder that may be in violation of applicable U.S. or foreign export laws or regulations.

The Electric Power Research Institute (EPRI)

The Electric Power Research Institute (EPRI), with major locations in Palo Alto, California, and Charlotte, North Carolina, was established in 1973 as an independent, nonprofit center for public interest energy and environmental research. EPRI brings together members, participants, the Institute's scientists and engineers, and other leading experts to work collaboratively on solutions to the challenges of electric power. These solutions span nearly every area of electricity generation, delivery, and use, including health, safety, and environment. EPRI's members represent over 90% of the electricity generated in the United States. International participation represents nearly 15% of EPRI's total research, development, and demonstration program.

Together...Shaping the Future of Electricity

© 2005 Electric Power Research Institute (EPRI), Inc. All rights reserved. Electric Power Research Institute and EPRI are registered service marks of the Electric Power Research Institute, Inc.

 Printed on recycled paper in the United States of America

1011804

ELECTRIC POWER RESEARCH INSTITUTE

3420 Hillview Avenue, Palo Alto, California 94304-1395 • PO Box 10412, Palo Alto, California 94303-0813 • USA
800.313.3774 • 650.855.2121 • askepri@epri.com • www.epri.com