

Qualification Testing for Metal Matrix Neutron Absorber Materials for Wet & Dry Storage Applications

1013723



Effective December 6, 2006, this report has been made publicly available in accordance with Section 734.3(b)(3) and published in accordance with Section 734.7 of the U.S. Export Administration Regulations. As a result of this publication, this report is subject to only copyright protection and does not require any license agreement from EPRI. This notice supersedes the export control restrictions and any proprietary licensed material notices embedded in the document prior to publication.

Qualification Testing for Metal Matrix Neutron Absorber Materials for Wet & Dry Storage Applications

1013723

Technical Update, November 2006

EPRI Project Managers
A. Machiels
R. Lambert

DISCLAIMER OF WARRANTIES AND LIMITATION OF LIABILITIES

THIS DOCUMENT WAS PREPARED BY THE ORGANIZATION(S) NAMED BELOW AS AN ACCOUNT OF WORK SPONSORED OR COSPONSORED BY THE ELECTRIC POWER RESEARCH INSTITUTE, INC. (EPRI). NEITHER EPRI, ANY MEMBER OF EPRI, ANY COSPONSOR, THE ORGANIZATION(S) BELOW, NOR ANY PERSON ACTING ON BEHALF OF ANY OF THEM:

(A) MAKES ANY WARRANTY OR REPRESENTATION WHATSOEVER, EXPRESS OR IMPLIED, (I) WITH RESPECT TO THE USE OF ANY INFORMATION, APPARATUS, METHOD, PROCESS, OR SIMILAR ITEM DISCLOSED IN THIS DOCUMENT, INCLUDING MERCHANTABILITY AND FITNESS FOR A PARTICULAR PURPOSE, OR (II) THAT SUCH USE DOES NOT INFRINGE ON OR INTERFERE WITH PRIVATELY OWNED RIGHTS, INCLUDING ANY PARTY'S INTELLECTUAL PROPERTY, OR (III) THAT THIS DOCUMENT IS SUITABLE TO ANY PARTICULAR USER'S CIRCUMSTANCE; OR

(B) ASSUMES RESPONSIBILITY FOR ANY DAMAGES OR OTHER LIABILITY WHATSOEVER (INCLUDING ANY CONSEQUENTIAL DAMAGES, EVEN IF EPRI OR ANY EPRI REPRESENTATIVE HAS BEEN ADVISED OF THE POSSIBILITY OF SUCH DAMAGES) RESULTING FROM YOUR SELECTION OR USE OF THIS DOCUMENT OR ANY INFORMATION, APPARATUS, METHOD, PROCESS, OR SIMILAR ITEM DISCLOSED IN THIS DOCUMENT.

ORGANIZATION(S) THAT PREPARED THIS DOCUMENT

Northeast Technology Corp.

NOTICE: THIS REPORT CONTAINS PROPRIETARY INFORMATION THAT IS THE INTELLECTUAL PROPERTY OF EPRI, ACCORDINGLY, IT IS AVAILABLE ONLY UNDER LICENSE FROM EPRI AND MAY NOT BE REPRODUCED OR DISCLOSED, WHOLLY OR IN PART, BY ANY LICENSEE TO ANY OTHER PERSON OR ORGANIZATION.

This is an EPRI Technical Update report. A Technical Update report is intended as an informal report of continuing research, a meeting, or a topical study. It is not a final EPRI technical report.

NOTE

For further information about EPRI, call the EPRI Customer Assistance Center at 800.313.3774 or e-mail askepri@epri.com.

Electric Power Research Institute and EPRI are registered service marks of the Electric Power Research Institute, Inc.

Copyright © 2006 Electric Power Research Institute, Inc. All rights reserved.

CITATIONS

This report was prepared by

Northeast Technology Corp.
108 North Front Street
UPO Box 4178
Kingston, NY 12402

Principal Investigator
K. Lindquist

This report describes research sponsored by the Electric Power Research Institute (EPRI).

This publication is a corporate document that should be cited in the literature in the following manner:

Qualification Testing for Metal Matrix Neutron Absorber Materials for Wet & Dry Storage Applications. EPRI, Palo Alto, CA: 2006. 1013723.

ABSTRACT

The report describes testing sequences to qualify candidate metal matrix neutron absorber materials for verifiable performance in service environments that are characteristic of spent fuel storage and transport applications. For a particular candidate material, sample type, sample configuration and sample number as well as test conditions for the intended service environment are specified. Detailed test procedures in five categories of material qualification testing are also provided. These categories, which are both application and material specific, are as follows:

- Accelerated corrosion
- Elevated temperature thermal
- Long-term radiation
- Short-term radiation
- Swelling and blistering

For each sample subjected to a particular test sequence, a series of pre-test and post-test measurements that are to be performed to evaluate the effects of the service environment on critical material parameters are described. Broadly, these critical material parameters include: dimensions, density, hardness, weight, mechanical properties, and ^{10}B areal density. Qualification for those candidate materials is expected to be validated when pre-test and post-test measurements are found to be within acceptable limits. Quality assurance requirements necessary to verify effective test implementation are also specified.

CONTENTS

1 INTRODUCTION & OBJECTIVES	1-1
2 PROJECT PLAN OVERVIEW	2-1
3 RELATED DOCUMENTS.....	3-1
4 SCOPE OF MATERIALS TO BE TESTED	4-1
5 PROJECT PLAN: ACCELERATED CORROSION TESTING	5-1
General	5-1
Test Matrix and Coupon Description	5-1
General.....	5-1
General Coupons with Scratches (Coated Coupons Only)	5-2
Bi-Metallic Galvanic Coupons.....	5-2
Weld Coupons.....	5-4
Crevice Coupons	5-4
Encapsulated Coupons	5-4
Schedule for Corrosion Coupon Testing	5-5
Inspection and Tests	5-6
Control of Test Conditions.....	5-7
6 PROJECT PLAN: ELEVATED TEMPERATURE THERMAL TESTING	6-1
General	6-1
Test Matrix and Coupon Description	6-1
Schedule for Elevated Temperature Testing.....	6-3
Inspections and Tests	6-3
Control of Test Conditions.....	6-3
7 PROJECT PLAN: LONG-TERM RADIATION TESTING FOR SPENT FUEL POOL APPLICATIONS	7-1

General	7-1
Test Matrix and Coupon Description	7-1
Schedule for Coupon Testing.....	7-3
Inspection and Tests	7-4
Control of Test Conditions.....	7-4
8 PROJECT PLAN: SHORT-TERM RADIATION TESTING FOR DRY STORAGE APPLICATIONS	8-1
General	8-1
Test Matrix and Coupon Description	8-1
Schedule for Coupon Testing.....	8-1
9 PROJECT PLAN: SWELLING & BLISTER TESTS	9-1
General	9-1
Test Matrix and Coupon Description	9-1
Schedule for Coupon Testing.....	9-1
Inspection & Tests.....	9-1
Control of Test Conditions.....	9-2
10 QUALITY ASSURANCE	10-1
General	10-1
Critical Elements	10-1
Administrative System.....	10-2
A SEP-244-01: PROCEDURE FOR ACCELERATED CORROSION TESTING OF ALUMINUM MATRIX NEUTRON ABSORBER MATERIAL COUPONS.....	A-1
Scope	A-1
Applicability	A-1
Related Documents.....	A-1
Required Test Equipment and Materials	A-2
Equipment Required.....	A-2
Materials Required	A-2
Coupon Designation.....	A-3
Coupon Racks and Testing Sequence.....	A-4
Procedure for Test Solution Preparation and Test Initiation.....	A-5
Procedure for Preparing Test Solutions	A-5

Procedure for Test Initiation	A-6
Procedure for Rack Loading.....	A-6
Procedure for 2000, 4000 and 6000 Coupon Rack Removal.....	A-7
Procedure for 8000 Hour Coupon Rack Removal	A-7
B SEP-244-02: PROCEDURE FOR SHORT-TERM ELEVATED TEMPERATURE TESTING OF ALUMINUM MATRIX NEUTRON ABSORBER MATERIAL COUPONS	B-1
Scope	B-1
Applicability	B-1
Related Documents.....	B-2
Required Test Equipment and Materials	B-2
Coupon Designation and Test Scope.....	B-2
Coupon Designation	B-2
Test Scope	B-3
Procedure for Test Performance and Data Recording	B-4
C SEP-244-03: PROCEDURE FOR LONG-TERM ELEVATED TEMPERATURE TESTING OF ALUMINUM.....	C-1
Scope	C-1
Applicability	C-1
Related Documents.....	C-2
Required Test Equipment and Materials	C-2
Coupon Designation and Test Scope.....	C-3
Coupon Designation	C-3
Test Scope	C-3
Procedure for Test Performance and Data Recording	C-4
D SEP-244-04: PROCEDURE FOR RADIATION TESTING OF ALUMINUM MATRIX NEUTRON ABSORBER MATERIAL COUPONS.....	D-1
Scope	D-1
Applicability	D-1
Related Documents.....	D-2
Required Test Equipment.....	D-2
Coupon Designation and Test Scope.....	D-2
Coupon Designation	D-2
Test Scope	D-4

Coupon Packets..... D-6
Procedure for Packet Assembly and Shipping D-6
Procedure for Test Irradiation..... D-7
Data Recording D-7

**E SEP-244-05: PROCEDURE FOR TESTING NEUTRON ABSORBER MATERIALS
UNDER SIMULATED CASK WETTING/ HYDRO TESTING & VACUUM DRYING
CONDITIONS E-1**

Scope E-1
Applicability E-1
Related Documents..... E-1
Required Test Equipment and Material..... E-1
Coupon Receipt Inspection/Test Preparation..... E-2
Procedure for Wetting/Hydro Simulation Test..... E-2
Procedure for Vacuum Drying Simulation Test E-4
Data Recording E-4

LIST OF FIGURES

Figure 5-1 Configuration of Bi-Metallic Galvanic Corrosion Coupon	5-3
Figure 5-2 Coupon Capsules	5-4
Figure 6-1 Reduced – Section Tension Specimens.....	6-2
Figure 7-1 Coupon Packet for Irradiation Testing	7-3
Figure 8-1 Coupon Packet for Irradiation Testing	8-2
Figure D-1 Coupon Packet	D-6
Figure E-1 Locations for Coupon Thickness Measurements	E-3

LIST OF TABLES

Table 2-1 Cask Storage Condition/Test Category/Test Environment/Critical Test Parameters.....	2-1
Table 2-2 Wet Storage Conditions/Test Category/Test Environment/Critical Test Parameters.....	2-3
Table 5-1 Coupon Test Matrix for Accelerated Corrosion Testing.....	5-2
Table 5-2 LWR Fuel Assembly Materials of Construction	5-3
Table 5-3 Number of Coupons Tested After 2000, 4000 and 6000 Test Hours	5-5
Table 5-4 Scope of Tests for Accelerated Corrosion Testing (General Coupons and Encapsulated Coupons Only)	5-6
Table 5-5 Scope of Tests for Accelerated Corrosion Tests (Crevice, Galvanic, Weld & Coated (Corrosion) Coupons Only).....	5-7
Table 6-1 Coupon Test Matrix for Thermal Testing	6-2
Table 6-2 Scope of Tests for the Short- and Long-Term Thermal Testing	6-4
Table 7-1 Coupon Test Matrix for Irradiation Testing	7-2
Table 7-2 Radiation Coupon Packet Contents.....	7-2
Table 7-3 Schedule of Coupon Packet Removal FNR Irradiation.....	7-3
Table 7-4 Scope of Tests for Irradiated Rectangular Coupons.....	7-4
Table 7-5 Scope of Tests for Irradiated Tensile Coupons	7-5
Table 8-1 Coupon Test Matrix for Irradiation Testing	8-2
Table 8-2 Radiation Coupon Packet Contents.....	8-2
Table 9-1 Inspection & Tests	9-2
Table A-1 The Number & Type of Coupons in Each Set	A-3
Table A-2 Number of Coupons Tested After 2000, 4000 and 6000 Hours	A-4
Table B-1 The Number and Type of Coupons in the Set.....	B-2
Table B-2 Scope of Tests for Short-Term Thermal Testing	B-4
Table C-1 The Number and Type of Coupons in the Set.....	C-2
Table C-2 Scope of Tests for the Long-Term Thermal Testing	C-4
Table D-1 Radiation Coupon Packet Contents	D-3
Table D-2 Schedule of Coupon Packet Removal Test Reactor Irradiation.....	D-4
Table D-3 Scope of Tests for Irradiated Rectangular Coupons	D-5
Table D-4 Scope of Tests for Irradiated Tensile Coupons.....	D-5
Table E-1 Summary of Test Conditions for AMNAM Coupons	E-5

1

INTRODUCTION & OBJECTIVES

This document contains a project plan for testing metal matrix neutron absorber materials in order to qualify such materials for use in spent fuel storage and transportation applications. This project plan does not apply to neutron absorbers with, for example, polymer-based matrices. Neutron absorber materials are used in spent fuel storage racks, dry storage casks as well as in transportation casks to control the reactivity state of the fuel in storage thereby preventing a criticality incident. The integrity of such neutron absorber materials in the proposed service environment and over the intended service life is of paramount importance in assuring the safe storage and transportation of spent nuclear fuel assemblies.

Spent fuel storage racks were typically designed for a 40-year service life. With nuclear plant license extension becoming the norm, racks in service today may be expected to be used for more than 60 years. Similarly, dry storage facilities originally licensed for 20 years are now being re-licensed for another 20 years. Further, delays in the opening of a federal repository could mean neutron absorber materials in storage casks would be in service for extended periods of time.

In spent fuel storage racks, the service environment to which neutron absorber materials are subjected includes exposure to massive doses of gamma radiation as well as lesser levels of fast neutron radiation. Additionally, the aqueous environment of the spent fuel pool presents special challenges with respect to corrosion considerations. When the matrix of the neutron absorber is a metal that differs from the structural material used for the storage racks, the potential for accelerated corrosion due to galvanic effects exist. In spent fuel racks, the neutron absorber material and structure are often two dissimilar materials separated by an electrolyte (demineralized water or boric acid).

Considering the service conditions in a dry storage or transportation cask, the neutron absorber materials are only exposed to water briefly during cask loading (and unloading) so that long-term corrosion effects need not be addressed. It is noted that short-term water exposure and the potential for the production of flammable corrosion products, such as hydrogen during fuel loading, poses a special hazard that must be addressed. The potential for ignition of such products during canister lid seal welding must be considered. As the fuel placed in storage casks is considerably aged relative to fuel that has been removed from the reactor and placed in storage racks, gamma and neutron sources associated with cooled fuel are significantly diminished. Accordingly, integrated radiation exposures are diminished greatly relative to a fuel rack applications.

During vacuum drying, neutron absorber material can be subjected to relatively high temperatures. Subsequent to vacuum drying and backfill with helium, the neutron absorber material will be at lower, yet elevated, temperatures for long periods of time. As the fuel decay

Introduction & Objectives

heat diminishes with time, the service temperature of the neutron absorber will gradually diminish. Throughout this protracted history of elevated temperatures, the matrix of the neutron absorber material must maintain its function of retaining the neutron absorber.

In order to evaluate potential neutron absorber materials for spent fuel applications, appropriately developed accelerated test programs are required. The need for such test programs is accentuated by the extended service life and potentially extreme service conditions for these materials as discussed previously. The test conditions must simulate the anticipated service conditions on an accelerated basis, as it is not practical to test materials over a 60-year service life. This project plan is an attempt to define the basic elements of and procedures for a sufficiently rigorous accelerated test program for qualifying new neutron absorber materials. The overall objective of the project plan is to provide a means for screening and selecting those neutron absorber materials that will maintain functional integrity throughout the design service life and beyond.

The project plan developed herein applies to new materials for which there has been little or no qualification testing completed. In some cases, qualification testing has been completed and publicly documented for materials that are similar to the new material being proposed. An example of similar material would include alloys with differing alloying species. In these cases engineering judgment and evaluations can be applied to adjust the required scope of the qualification testing described herein.

The following sections of this document contain an overview of the project plan as well as a detailed description of each test. Included in the appendices are procedures for conducting the tests on candidate aluminum matrix neutron absorber materials.

2

PROJECT PLAN OVERVIEW

A typical series of tests have been developed to evaluate candidate materials on an accelerated basis for application in cask storage and transportation as well as for application in spent fuel racks.

For cask storage and transportation applications, the test matrix is defined in Table 2-1. Test 1 is intended to identify the potential for the production of flammable corrosion products (hydrogen) during cask loading. If such flammable gases are produced, this test would further serve to quantify the rate at production so as to provide a basis for establishing limits and precautions for canister lid welding procedures.

Table 2-1
Cask Storage Condition/Test Category/Test Environment/Critical Test Parameters

Test No.	Storage Condition	Test Category	Test Environment	Critical Test Parameter
1	Cask loading	Short-term aqueous	Demin water or boric acid @ 200°F	Hydrogen generation
2	Cask drying	Short-term high temperature	900°F for 48 hours	Dimensional/density stability Change of mechanical properties Areal density Changes at particle/metal interface
3	Cask drying	Cycling/vacuum drying	Temperature/Pressure/Cycle Bounding for specific cask	Clad delamination and swelling +
4	Cask storage	Long-term high temperature	750°F for 1 year	As in 2 above
5	Cask storage	Accelerated radiation	Fast neutron $\geq 1 \times 10^{17}$ nvt	As in 2 above
+ For clad materials and materials at less than theoretical density				

Test 2 is intended to demonstrate the ability of candidate absorber material to adequately withstand exposure to the high temperatures, which the materials would be exposed to during cask

Project Plan Overview

vacuum drying. Test 2 would apply to all candidate materials and would verify dimensional/density stability, acceptable mechanical properties and areal density after testing. In addition, electron microscopy (SEM or TEM) can be used to determine if there are changes at the particle/metal matrix interface that could eventually lead to unacceptable material performance.

Test 3 applies to proposed neutron absorber materials that are less than full density. These materials would have internal porosity through which water could enter. Subsequent thermal cycling has the potential for swelling and, if the materials are clad, a delamination of the clad. The test environment should be selected so that the test temperature/pressure history selected bounds the history projected for a specific cask. For transportation casks, where the neutron absorber will be subjected to numerous wetting/drying cycles, the neutron absorber material needs to be tested for an adequate number of cycles. For storage applications where the material would normally be exposed to one wetting/drying cycle, testing should be conducted for three cycles. This will conservatively bound the situation in which the cask must be reflooded and opened.

Test 4 is intended to demonstrate acceptable material performance at elevated temperatures over the design service life of a storage cask. In this test, the test temperature is specified as being significantly higher than the projected average temperature during service as the test is completed on an accelerated basis in one year. The post-exposure testing is designed to determine acceptable material performance as in Test 2 above.

During the neutron absorber service life in dry storage casks, these materials will be subjected to fast neutrons from spontaneous fissions. The integrated exposure is anticipated to be low and less than about 1×10^{17} nvt. The material can be exposed to this level of exposure at the face of a test reactor in a short time. Acceptable material performance is determined by measurements as in Tests 2 and 4.

For spent fuel rack applications, the tests matrix is specified in Table 2-2. Test 1 and 2 are accelerated corrosion tests under BWR and PWR conditions, respectively. Both tests are conducted at temperature somewhat elevated relative to the maximum temperature expected in a spent fuel pool so as to assess corrosion behavior on an accelerated basis. Corrosion rates via weight changes, as well as local effects including pitting corrosion, galvanic corrosion between dissimilar metals and crevice corrosion are measured.

In spent fuel racks, neutron absorber material can be expected to be exposed to high levels of gamma radiation and lesser levels of fast neutron fluence. This is the case as the gamma sources associated with freshly discharged fuel assemblies (one week cooling time) are substantial with gamma energy deposition rates in the rack structure and neutron absorber of 1×10^7 rads/hour or more. Further, it is generally the preference of plant operators to discharge fuel from the reactor into the same spent fuel rack modules at each refueling outage. Accordingly, integrated gamma exposure levels of up to 1.5×10^{11} rads and beyond can be experienced. While metals are largely unaffected by gamma radiation, prudence suggests that the combined effects of massive doses of gamma radiation and lesser exposure to fast neutrons be tested. The critical parameters to be tested include dimensional/density stability, mechanical properties, boron-10 areal density, weight and hardness changes.

**Table 2-2
Wet Storage Conditions/Test Category/Test Environment/Critical Test Parameters**

Test No.	Storage Condition	Test Category	Test Environment	Critical Test Parameter
1	BWR Pool Storage	Accelerated Corrosion	195°F for 1 year in demineralized water	Oxide film and weight change, pitting, crevice and galvanic corrosion
2	PWR Pool Storage	Accelerated Corrosion	195°F for 1 year in boric acid	As in 1 above
3	PWR/BWR Pool Storage	Accelerated Irradiation	Gamma exposure > 1.5 x 10 ¹¹ rads	Dimensional/density stability mechanical properties/areal density weight change, hardness change

3

RELATED DOCUMENTS

The following Special Engineering Procedures (SEPs) will guide and control the test programs and coupon inspections and measurements. The SEPs are applicable as written to the testing of aluminum matrix absorber material, since this general category of material is most often proposed and considered. The procedures can be adapted to test alternative candidate materials. The procedures are contained in the appendices to this report and are as follows:

Test Procedures

- SEP-244-01 Procedure for Accelerated Corrosion Testing of Aluminum Matrix Neutron Absorber Material Coupons
- SEP-244-02 Procedure for Short-Term Elevated Temperature Testing of Aluminum Matrix Neutron Absorber Material Coupons
- SEP-244-03 Procedure for Long-Term Elevated Temperature Testing of Aluminum Matrix Neutron Absorber Material Coupons
- SEP-244-04 Procedure for Radiation Testing of Aluminum Matrix Neutron Absorber Material Coupons
- SEP-244-05 Procedure for Testing Neutron Absorber Materials under Simulated Cask Wetting/Hydro Testing and Vacuum Drying Conditions

Additional procedures, SEP-244-06 through SEP-244-12, are second-level procedures that are used in the qualification process, but are not detailed in this report.

4

SCOPE OF MATERIALS TO BE TESTED

The total number of coupons comprising a test program depends on a number of factors including the configuration of the absorber in a particular application, structural and other materials in contact with the absorbers, e.g., fastening methods employed, etc. A typical test program might include a total of 294 coupons (138 coupons for accelerated corrosion testing, 60 coupons for thermal testing, and 96 coupons for radiation testing). Test matrices will include coupons of both intermediate without absorber and maximum without absorber material.

Candidate absorber material may be mill finished or it may be protectively coated. For example, aluminum matrix absorber material may be anodized to provide oxidation protection. In the test sequences below, mill finish has been selected as the representative example of candidate material. If it were intended to contrast the behavior of mill and protective coated material, then accelerated corrosion testing would be performed for both types of material. Correspondingly, the total number of coupons to be tested would increase and the test matrices would be appropriately modified.

Weld coupons have been included in the accelerated corrosion, thermal and irradiation test phases. The purpose of these coupons is to determine whether the weld alloy or the heat-affected zone is impacted by the proposed service environment. Some weld specimens subject to elevated temperature and radiation testing will be tested for tensile strength, yield strength and elongation.

In order to develop as-fabricated baseline data for particular material properties, archive coupons will be retained and tested. Archive coupons will not be subjected to the test environments described above and are, therefore, not counted among the 294 coupons designated for these categories of testing. Eighteen archive coupons will be included in the test program.

5

PROJECT PLAN: ACCELERATED CORROSION TESTING

General

The accelerated corrosion test program has been designed to determine the susceptibility of proposed neutron absorber materials to general (uniform) and localized (pitting) corrosion in PWR and BWR spent fuel pools. Two sets of coupons are to be tested: one set in deionized water, simulating BWR pool conditions, and one set in deionized water containing 2,500 ppm boron as boric acid, simulating PWR pool conditions. Both tests are run at 195°F (90.5°C) to accelerate any corrosion effects for ~8,000 hours (11 months). The tests are accelerated by conducting the tests at temperatures, which are elevated relative to typical temperatures in the planned service environment. Typically, spent fuel pools are operated in the temperature range of 80 to 100°F (27 - 38°C) with short-term excursions to 130°F (54°C), which occur during refueling outages. The procedure for conducting these tests for aluminum matrix absorbers is contained in Appendix A.

Test Matrix and Coupon Description

The test matrix for the accelerated corrosion test is shown in Table 5-1. A total of 138 coupons are to be tested; 69 in deionized water and 69 in 2,500 ppm boron as boric acid. A description of each coupon type is given below:

General

General coupons will be rectangular (2 inch x 4 inch x nominal thickness). The purpose of these coupons is to determine the rate at which a uniform oxide film forms. The rate of oxide build-up will be determined by changes in the coupon weight and thickness. The coupons will be subject to precision weighing prior to testing and after a nitric acid wash and drying after testing.

Project Plan: Accelerated Corrosion Testing

**Table 5-1
Coupon Test Matrix for Accelerated Corrosion Testing**

Sample Type	Deionized Water		Boric Acid	
	Intermediate w/o absorber	Max w/o absorber	Intermediate w/o absorber	Max w/o absorber
Mill Finish				
General	10	10	10	10
Crevice	10		10	
Galvanic	9		9	
Weld	10		10	
Encapsulated	10	10	10	10
Total Number of Coupons for Corrosion Testing – 138				

General Coupons with Scratches (Coated Coupons Only)

Scratches will be applied with a scribe to the coated coupons to simulate handling scratches which would be anticipated during assembly/fabrication of cask baskets or fuel racks. The corrosion performance of these scratched coupons will be assessed via optical microscopy.

Bi-Metallic Galvanic Coupons

In conventional spent fuel racks, the neutron absorber material is enclosed in 304 L stainless steel wrapper plate so that the potential for aluminum/stainless steel galvanic corrosion exists. Because of the improved mechanical properties of neutron absorber materials, it is possible that this material would be used unsheathed so that it could be in contact with by LWR fuel assemblies. Of the materials in LWR fuel assemblies supplied by U.S. fuel manufacturers, only stainless steel, Inconel and Zircaloy could contact the surface of fuel racks as shown in Table 5-2. Accordingly, bi-metallic coupons will be prepared with the neutron absorber and:

- 304-L stainless steel
- Inconel 718
- Zircaloy 2

**Table 5-2
LWR Fuel Assembly Materials of Construction**

Fuel Assembly Component	Materials which could contact fuel rack/cask baskets						
	Westinghouse (CE Fuel)		Framatome (B&W)	Framatome (Siemens)		Westinghouse	G.E.
	BWR	PWR		BWR	PWR		
Top & Bottom Nozzles	SS-304	SS-304	SS-CF3M	SS-ANF	SS-ANF	SS-304	SS-304
Grid Spacers	Zirc 4	In-625 Zirc 4	In-718	In-718 Zirc 4	In-718 Zirc 4	In-718 Zirc 4	Zirc 4 In X 750
Fuel Rods	Zirc 2	Zirc 4	Zirc 4	Zirc 2	Zirc 4	Zirc 4 SS-304 SS-348 SS-347	Zirc 2
Fuel Channel	Zirc 4			Zirc 4			Zirc 4
Channel Spring	In x 750			In x 750			In x 750

The above alloys will be 2 inch x 4 inch x nominal thickness inch and will have a staircase machine pattern on one flat face as shown in Figure 5-1. When placed in contact with a neutron absorber coupon will provide various distances (gaps) between the coupled metals. The two metals comprising each coupon will be fastened to each other mechanically.

Inspection of the galvanic coupons will be via optical microscopy. Acid cleaning will be used depending on the depth of any oxide films.

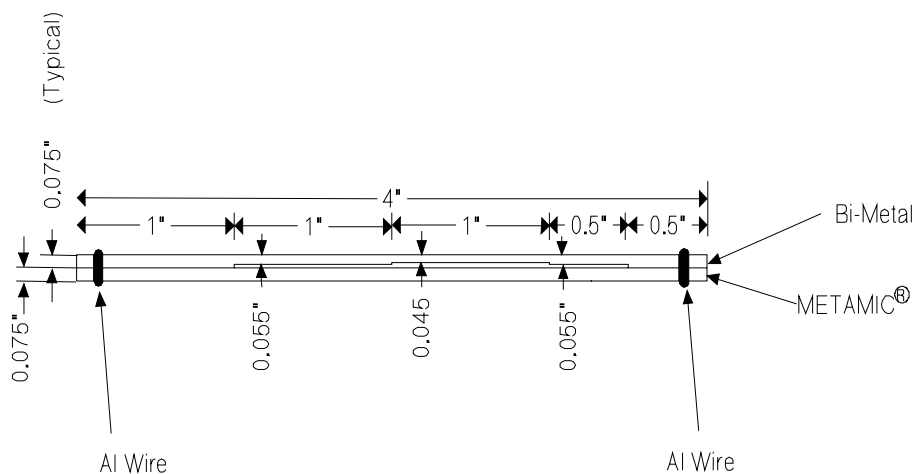

**Figure 5-1
Configuration of Bi-Metallic Galvanic Corrosion Coupon**

Weld Coupons

The weld coupons will also be 2 inch x 4 inch x nominal thickness inch with the weld running across the coupon width midway along its length. The weld will be a butt weld with the weld bead machined flush with the surface of the absorber material. The weld coupon will be inspected via optical microscopy. Acid cleaning will be performed as needed.

Crevice Coupons

The crevice coupons will also be 2 inch x 4 inch x nominal thickness inch with two 0.250-inch holes in them. The holes will be used to attach two crevice forming Teflon washers via Teflon machine screws and an insulating shoulder washer.

Encapsulated Coupons

Coupons encapsulated in stainless steel capsules have been included to simulate the semi-stagnant conditions around the neutron absorber which would prevail in fuel racks. The capsules are formed from three pieces of stainless steel as shown in Figure 5-2. The capsules are basically two flat plates of stainless steel which form a sandwich with a third “picture frame” configured stainless steel piece. The three pieces are held together by four stainless steel machine screws and nuts. The coupon resides in the volume created inside the picture frame. The inlet and outlet slots are sized to simulate the fluid exchange rate (between inner volume around the coupons and bulk pool volume) as expected in a spent fuel rack condition. For this test, a minimum exchange rate of ~0.1 volumes per day was conservatively selected.

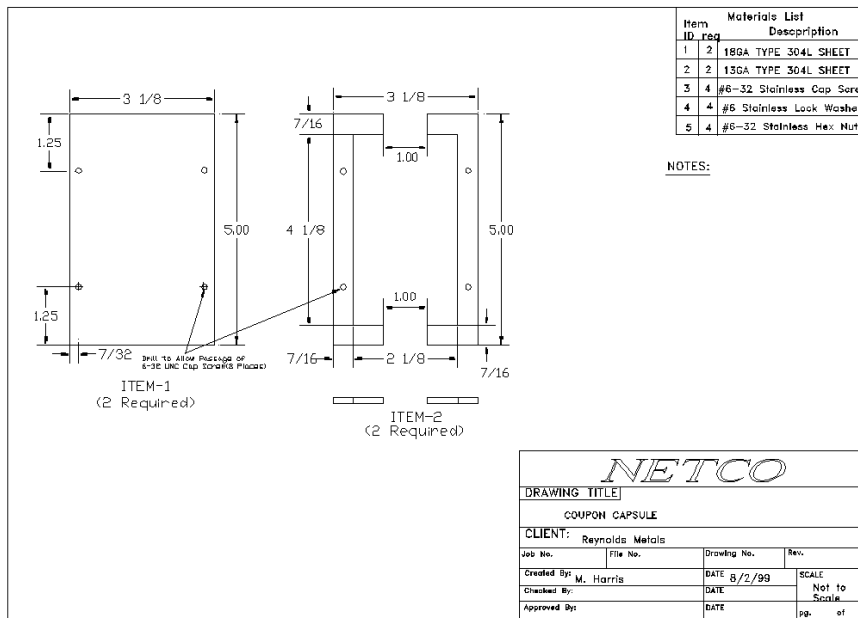

Figure 5-2
Coupon Capsules

Schedule for Corrosion Coupon Testing

The accelerated corrosion testing will be conducted at 195°F. The elevated temperature test environment is expected to accelerate corrosion effects relative to typical spent fuel pool conditions (80°F to 100°F). Corrosion effects are generally governed by an Arrhenius function of temperature.

The tests will be conducted over ~ 8000 hours (~ 11 months). Testing of corrosion coupons will be performed at approximately the following intervals:

- 2000 hours
- 4000 hours
- 6000 hours
- 8000 hours

Select coupons will be removed at the intermediate test intervals (2000, 4000 and 6000 hours) and post-test characterization will be performed. For post-test characterization, the coupons will be inspected either non-destructively or destructively. Because the coupons will be removed from the corrosion test baths, it is possible that the corrosion process may be disturbed. Returning the inspected coupons to the test baths and subsequent testing could introduce scatter in the data and complicate data interpretation. Accordingly, these coupons will not be returned for subsequent exposure in the corrosive bath coupon characterization performed subsequent to the 2000, 4000 and 6000 hour tests will be considered post test characterization.

Table 5-3 contains the number of coupons to be removed after 2000, 4000 and 6000 test hours. At the completion of the test (8000 hours), there will be remaining 4 coupons of the original 10 coupons of each type shown in Table 5-1. Each will be subject to post test characterization.

**Table 5-3
Number of Coupons Tested After 2000, 4000 and 6000 Test Hours**

Sample Type	Deionized Water		Boric Acid	
	Intermediate w/o absorber	Max w/o absorber	Intermediate w/o absorber	Max w/o absorber
Mill Finish				
General	2	2	2	2
Crevice	2		2	
Galvanic	3		3	
Weld	2		2	
Encapsulated	2	2	2	2
A – One of each type of bi-metallic coupon removed and subject to post-test characterization at 4000 hours. The rest of the galvanic samples will be inspected at 8000 hours.				

Inspection and Tests

Table 5-4 contains the tests and inspections to be conducted prior to testing, during interim tests and for the post-test characterization for the general coupons and encapsulated coupons. Table 5-5 contains a similar test description for the crevice corrosion, galvanic, weld and scratched (coated) coupons.

**Table 5-4
Scope of Tests for Accelerated Corrosion Testing (General Coupons and Encapsulated Coupons Only)**

Test	Pre-Test Characterization	Post-Test Characterization
Visual Inspection	✓	✓
High Resolution Photography	✓	✓
Dimensions	✓	✓
Dry Weight	✓	✓
Neutron Attenuation ²	✓	✓
Chemical Characterization	OPT	OPT
Acid Cleaning		✓
Weight Loss		✓
Surface characterization via Metallography for: ²		
Oxide Film	1	✓ ²
Pit Size and Depth	1	✓ ²
1 – Retain archive samples (for comparison to post test data) 2 – Select samples only		

**Table 5-5
Scope of Tests for Accelerated Corrosion Tests (Crevice, Galvanic, Weld & Coated
(Corrosion) Coupons Only)**

Test	Pre-Test Characterization	Post-Test Characterization
Visual Inspection	✓	✓
High Resolution Photography	✓	✓
Quantitative Optical Microscopy		✓
Surface Characterization		
Via Microscopy for:		
Oxide Film Thickness		✓ ¹
Pit Size and Depth		✓ ¹
1 – As required and at the discretion of the project manager		

Control of Test Conditions

The demineralized water used for preparation of the corrosion fluids will be prepared in the laboratory using mixed bed resins similar to those used at spent fuel pools. The water will be chemically tested for silica, chlorine, pH and conductivity. The boric acid solutions will be prepared using this demineralized water and reagent grade boric acid. Periodically, and at a frequency to be determined by the project manager, samples from both water volumes will be taken and analyzed for silica, chlorine, boron (PWR test only), pH and conductivity. The frequency for water sampling will be determined by initial measurement results and the range of variability encountered.

The constant temperature baths will be maintained at 195°F (90.5°C). Circulators (performance specification ± 0.2°F) are provided to maintain uniformity of water temperature. Bath temperatures will be monitored with a thermometer with 1°C resolution and ± 1°C accuracy and/or thermocouples. The corrosion baths will be fitted with gabled stainless covers to minimize evaporation. Makeup for evaporative losses will be made with deionized water. Records of the date, time and volume of makeup water added will be maintained.

6

PROJECT PLAN: ELEVATED TEMPERATURE THERMAL TESTING

General

Elevated temperature thermal testing will be completed to conservatively simulate conditions which prevail in dry cask applications. Two tests will be performed. The first is a long-term (8000 hour) test at 750°F (399°C) in air. The air test environment is conservative as the service environment in casks is a helium atmosphere. After 2000 hours, and at 2000 hour intervals thereafter, specific coupons will be removed, cooled and tested. A second test will simulate cask vacuum drying operations and will include a 900°F (482°C) test for two days. To minimize surface oxidation during this test, the coupons will be heated in a helium rich atmosphere. Coupons will be tested before and after heating.

Appendices B and C contain procedures for conducting the short-term and long-term elevated temperature tests.

Test Matrix and Coupon Description

The test matrix for short- and long-term thermal testing is shown in Table 6-1. Two configurations of coupons are included; rectangular coupons (2 inch x 4 inch x nominal thickness inch) which are identical to the general coupons used in the corrosion tests and tensile coupons. The latter are 1 inch x 8 inch x nominal thickness inch reduced section tension specimens as shown in Figure 6-1.

Project Plan: Elevated Temperature Thermal Testing

**Table 6-1
Coupon Test Matrix for Thermal Testing**

Sample Type	Long-Term in Air @ 750° (399°C)		Short-Term in Inert Atm @ 900°F (482°C)	
	Intermediate w/o neutron absorber	Max w/o neutron absorber	Intermediate w/o neutron absorber	Max w/o neutron absorber
General				
Rect. Coupons	5	5	5	5
Tensile Coupons	5	5	5	5
Weld				
Rect. Coupons	5		5	
Tensile Coupons	5		5	

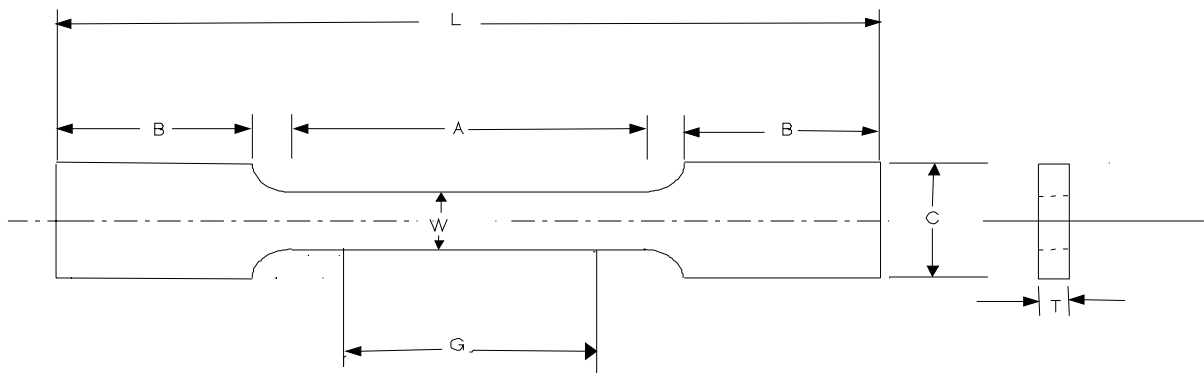

G - Gage length	2.000 ± 0.005
W - Width (Note1)	0.75 ± 0.010
T - Thickness	.075
R - Radius of fillet, min	½
L - Over-all length, min	8
A - Length of reduced section, min	2 ¼
B - Length of grip section, min (Note 2)	2
C - Width of grip section, approximate (Note 3)	1.0

NOTE 1 - The ends of the reduced section shall not differ in width by more than 0.002 in.

NOTE 2 - It is desirable, if possible, to make the length of the grip section large enough to allow the specimen to extend into the grips a distance equal to two thirds or more of the length of the grips.

NOTE 3 - The ends of the specimen shall be symmetrically with the center line of the reduced section within 0.01 and 0.005 in., respectively.

**Figure 6-1
Reduced – Section Tension Specimens**

Schedule for Elevated Temperature Testing

The short-term test at 900°F (482°C) will be run first followed by the long-term test. The long-term test at 750°F (399°C) will be conducted over a period of ~11 months (8000 hours). Testing of coupons will be conducted at approximately the following intervals:

- 2000 hours
- 4000 hours
- 6000 hours
- 8000 hours

Testing at the intermediate test intervals (2000, 4000, and 6000 hours) will be conducted as either interim testing or post-test characterization. In the former, the coupons will be inspected and tested non-destructively. After testing, they will be returned to the test oven. In the latter, the coupons will be tested destructively (tensile coupons) and will not be returned to the test environment. One tensile coupon of each type will be subject to tensile testing at 2000, 4000 and 6000 hours (a total of 4 coupons at each intermediate test interval). At the end of the test, there will remain a total of 2 coupons of each type (a total of 12 coupons) for tensile testing.

Inspections and Tests

For long-term thermal tests, the inspection and test to be performed prior to testing, during interim testing and post-test are shown in Table 6-2. For the short-term thermal tests, the scope of pre- and post-test inspections is identical. However, no interim inspections are performed for the short-term thermal tests. It is noted that neutron radiography will be performed on all weld specimens scheduled for tensile testing to assure that possible porosity in the weld material or heat-affected zone does not complicate data evaluation.

Control of Test Conditions

During the short-term thermal tests, the furnace will be continuously purged with helium. This will minimize the extent of surface oxidation. The long-term tests will be conducted in air. For both tests, the temperature of the furnace will be monitored with thermocouples.

Project Plan: Elevated Temperature Thermal Testing

**Table 6-2
Scope of Tests for the Short- and Long-Term Thermal Testing**

Test	Pre-Characterization	Interim⁺	Post-Characterization
Visual Inspection	✓	✓	✓
High-Resolution Photography	✓	✓	✓
Dimensions	✓	✓	✓
Dry Weight	✓	✓	✓
Density	✓		✓
Tensile Strength ¹	✓		✓
Yield Strength ¹	✓		✓
Elongation ¹	✓		✓
Neutron Attenuation ²	✓		✓
Radiography ³	✓		
Chemical Characterization	OPT		OPT
SEM or TEM	OPT		OPT

7

PROJECT PLAN: LONG-TERM RADIATION TESTING FOR SPENT FUEL POOL APPLICATIONS

General

The radiation test program is designed to determine the stability of proposed neutron absorber when subjected to intense levels of gamma radiation and lesser levels of neutron radiation as would be experienced in spent fuel pools. A series of coupons packets will be irradiated in a specially designed and custom fabricated canister at a test reactor. The canister will serve as a thermal neutron shield to minimize the amount of thermal neutron energy deposited in the coupons. (In both spent fuel racks and casks, the neutron fluxes are relatively low.) The canister has inlet and outlet cooling ports, designed with baffles, to preclude neutron streaming. Cooling is via natural circulation of the reactor pool water.

Periodically, sample packets will be removed by from the test reactor and shipped to a qualified laboratory for testing.

A procedure for conducting a long-term radiation test is contained in Appendix D.

Test Matrix and Coupon Description

As shown in Table 7-1, three types of coupons are to be included in the radiation test matrix; 2 inch x 4 inch x nominal thickness rectangular coupons, 1 inch x 8 inch x nominal thickness reduced section tensile coupons (see Figure 6-2) and similarly sized tensile coupons of weld materials. Wire of an appropriate material will be used to secure each packet of 12 coupons. Table 7-2 contains the contents of each coupon packet. The coupons will be packaged in 8 packets of 12 coupons each as shown in Figure 7-1.

Project Plan: Long-Term Radiation Testing for Spent Fuel Pool Applications

**Table 7-1
Coupon Test Matrix for Irradiation Testing**

Sample Type	Neutron Absorber Loading	
	Intermediate w/o	Maximum w/o
General		
Rect. Coupons	16	16
Tensile Coupons	24	24
Weld		
Tensile Coupons	8	8

**Table 7-2
Radiation Coupon Packet Contents**

Packet No.	Rectangular		Tensile		
	Int. w/o absorber	Max w/o absorber	Int. w/o absorber	Max w/o absorber	Weld
1	2	2	3	3	2
2	2	2	3	3	2
3	2	2	3	3	2
4	2	2	3	3	2
5	2	2	3	3	2
6	2	2	3	3	2
7	2	2	3	3	2
8	2	2	3	3	2
Totals	16	16	24	24	16

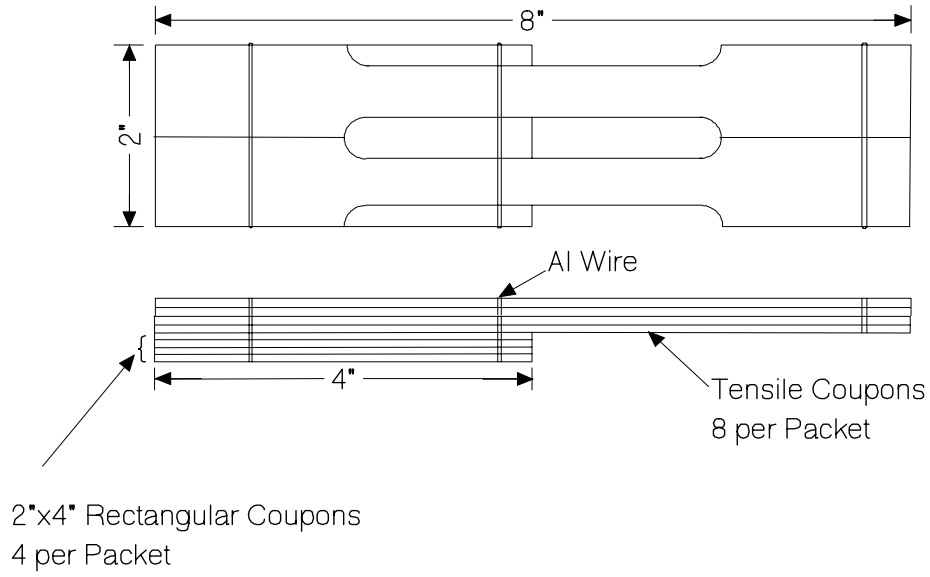

Figure 7-1
Coupon Packet for Irradiation Testing

Schedule for Coupon Testing

The schedule for coupon removal from the test reactor and the target exposure of each packet is shown in Table 7-3. This schedule has been developed to maximize the number of coupons tested at the higher accumulated gamma exposure to improve the statistics of the test data.

The coupon packet exposures in Table 7-3 are approximate and are to be verified during the initial weeks of testing via dosimetry.

Table 7-3
Schedule of Coupon Packet Removal FNR Irradiation

Approximate Irradiation Time, months	Coupon Gamma Exposure, rads*	Number of Packets Removed
0.5	6.0×10^9	1
1.0	1.2×10^{10}	1
3.0	4.8×10^{10}	1
5.0	7.5×10^{10}	1
6.0	1.0×10^{11}	1
12.0	2.0×10^{11}	3

* Based on an exposure rate of 5×10^7 rads/hour at the core face of a typical test reactor. Exposure rate to be verified via dosimetry during the initial weeks of irradiation.

Inspection and Tests

The irradiated coupons are to be subjected to pre-characterization and post-test characterization.

Table 7-4 specifies the pre- and post-test characterizations to be performed on the rectangular coupons scheduled for irradiation. The testing to be performed on the tensile coupons is shown in Table 7-5. It is noted that the weld specimens scheduled for tensile testing will be subject to neutron radiography during pre-characterization. This is to determine whether the welds contain porosity and will help facilitate evaluation of the tensile data.

Table 7-4
Scope of Tests for Irradiated Rectangular Coupons

Test	Pre-Characterization	Post-Characterization
Visual Inspection	✓	✓
High-Resolution Photography	✓	✓
Dry Weight	✓	✓
Density	✓	✓
Hardness	✓	✓
Neutron Attenuation ¹	✓	✓
Chemical Assay	OPT	OPT
SEM or TEM	OPT	OPT
1 On select coupons only OPT: At the option of the project manager		

Control of Test Conditions

The coupon packets will be irradiated under controlled conditions at a suitable test reactor, at which the neutron flux has been accurately characterized at the various locations where the specially designed customized canister is to be placed. During irradiation, the canister and the coupons will be immersed in deionized water in the reflector tank. The operating staff will periodically monitor tank temperature. Designated packets will be removed from the canister at such times as gamma exposure levels in Table 7-3 are attained.

Table 7-5
Scope of Tests for Irradiated Tensile Coupons

Test	Pre-Characterization	Post-Characterization
Visual Inspection	✓	✓
High-Resolution Photography	✓	✓
Dimensions	✓	✓
Dry Weight	✓	✓
Density	✓	✓
Hardness	✓	✓
Neutron Radiography ¹	✓	
Chemical Assay	OPT	OPT
Tensile Strength	✓	✓
Yield Strength	✓	✓
Elongation	✓	✓

8

PROJECT PLAN: SHORT-TERM RADIATION TESTING FOR DRY STORAGE APPLICATIONS

General

If the test program specified in SEP-244-04 is completed, no further radiation testing is required for dry storage applications. If the neutron absorber material is being qualified for dry storage applications only, then the following abbreviated radiation program is to be completed.

This radiation test program is designed to determine the stability of proposed neutron absorber when subjected to levels of gamma radiation and fast neutron radiation in excess of those expected during the service life in a dry storage application. A series of coupons will be irradiated in a specially designed and custom fabricated canister at a test reactor. The canister will serve as a thermal neutron shield to minimize the amount of thermal neutron energy deposited in the coupons. The canister has inlet and outlet cooling ports, designed with baffles, to preclude neutron streaming. Cooling is via natural circulation of the reactor pool water.

At the end of the radiation period, the coupons will be removed by from the test reactor and shipped to a qualified laboratory for testing.

A procedure for conducting a short-term radiation test can be adapted from the procedure contained in Appendix D.

Test Matrix and Coupon Description

As shown in Table 8-1, three types of coupons are to be included in the radiation test matrix; 2 inch x 4 inch x nominal thickness rectangular coupons, 1 inch x 8 inch x nominal thickness reduced section tensile coupons and similarly sized tensile coupons with welds. Wire of an appropriate material will be used to secure the coupons into 2 packets of 12 coupons each. Table 8-2 contains the contents of each coupon packet. The coupons will be packaged in 2 packets of 12 coupons each as shown in Figure 8-1.

Schedule for Coupon Testing

The radiation interval shall be selected such that at the end of the interval the coupons will have sustained a fast neutron fluence of at least 1×10^{17} nvt.

Project Plan: Short-Term Radiation Testing for Dry Storage Applications

**Table 8-1
Coupon Test Matrix for Irradiation Testing**

Sample Type	Neutron Absorber Loading	
	Intermediate w/o	Maximum w/o
General		
Rect. Coupons	4	4
Tensile Coupons	4	4
Weld		
Tensile Coupons	4	4

**Table 8-2
Radiation Coupon Packet Contents**

Packet No.	Rectangular		Tensile		Weld Tensile	
	Int. w/o absorber	Max w/o absorber	Int. w/o absorber	Max w/o absorber	Int. w/o absorber	Max w/o absorber
1	4		4		4	
2		4		4		4
Totals	4	4	4	4	4	4

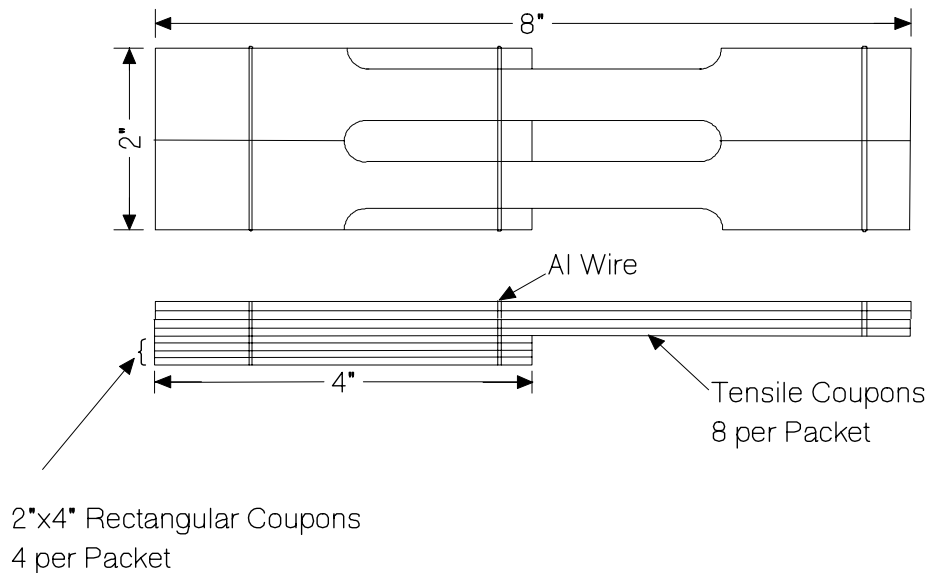

**Figure 8-1
Coupon Packet for Irradiation Testing**

9

PROJECT PLAN: SWELLING & BLISTER TESTS

General

Should a neutron absorber material be susceptible to swelling and/or clad delamination and the formation of blisters, qualification testing shall be completed. Materials susceptible to blistering include clad absorbers that have a core density that contain porosity. In this case, the test environment should simulate the conditions to which the absorber is subjected during canister loading, lid seal welding and vacuum drying.

Test Matrix and Coupon Description

A sufficient number of coupons should be tested so as to include material from a number of production lots in the test matrix. The coupons should be sized such that the test results are representative of the behavior of full-size panels of the neutron absorber material. For this purpose, the minimum size shall include full-width coupons with a minimum length of 12 inches.

Schedule for Coupon Testing

The schedule for wetting, pressurization and vacuum drying shall be selected so as to bound the most adverse conditions expected during canister loading, lid seal welding, canister draw down and vacuum drying. For these purposes, the thermal and pressure history during bounding conditions are generally provided in the Certificate of Compliance (CoC) document and/or Final Safety Analysis Report (FSAR) for the cask.

Inspection & Tests

The coupons shall be subjected to inspection and testing as shown in Table 9-1. The coupons are subject to testing and inspection prior to testing (pre-characterization), after wetting and prior to drying (interim) and after vacuum drying (post-test characterization). Visual inspection may include high-resolution photography if anomalies are observed.

Thickness measurement shall be performed at a sufficient number of locations on each coupon so that changes in thickness can be readily identified. For this size coupon, nine locations are judged to be a sufficient number. The coupons shall be measured at the same locations pre- and post-testing. Optional microscopy at the site of blisters is recommended. Destructive examination may reveal information with respect to the cause of blisters and the blister formation mechanism.

Control of Test Conditions

In order to assure test reproducibility, the test conditions shall be carefully controlled. For this purpose, programmable thermal and pressure controls are recommended to control the temperature and pressure (or vacuum) of the wetting and drying vessels.

Table 9-1
Inspection & Tests

Test	Pre-Characterization	Interim	Post-Test Characterization
Visual Inspection	✓	✓	✓
Thickness Measurements	✓		✓
Weight	✓	✓	✓
Microscopy			OPT
Destructive Exam			OPT

10

QUALITY ASSURANCE

General

Candidate metal matrix neutron absorber materials, which successfully qualify for nuclear safety-related application, must be qualified through implementation of a testing process that conforms with the requirements of 10 CFR 50 Appendix B, 10 CFR 21 and with nuclear industry quality standards, as put forth in ANSI/ASME N 45.2. A viable project plan must, therefore, be implemented within an administrative system that includes measures and procedures to assure that qualification testing is performed in compliance with all applicable codes and standards.

Critical Elements

Six critical administrative and procedural elements, the control of which is key to verifiably effective implementation of the “Qualification Testing for Metal Matrix Neutron Absorber Materials for Wet and Dry Storage Applications” are as follows:

- Test Control

Test controls are to be adequate to assure that characteristics to be tested and the test methods employed are documented, pre-specified, and have been adequately designed to accurately model the service environment of the candidate neutron absorber material. Qualification tests are to be performed by properly trained and qualified personnel. Prior to implementation, all test procedures are to be reviewed and approved by responsible and knowledgeable personnel.

- Control of Measuring & Test Equipment

All qualification testing is to be performed using instruments and measuring equipment, which prior to use, has been calibrated and has been adjusted to maintain accuracy within necessary limits. As appropriate, calibration is to be performed in accordance with and accompanied by NIST traceable standards and calibration certificates.

- Test Status

The test status of all samples of candidate neutron absorber material is to be identified on the sample and/or in documents traceable to the sample. The documentation is to provide assurance that all required qualification testing has been performed as well as assurance that the associated test results have been accurately analyzed and recorded.

- Sample Identification & Control

Materials and samples subjected to qualification testing are to be identified and uniquely labeled with suitable levels of control to assure that there exists accurate, verifiable and

Quality Assurance

traceable correspondence between item and test results attributable to specified tests performed on particular material or sample.

- **Handling & Storage Control**

Materials and samples that are scheduled for or have already been subjected to qualification testing are to be handled and stored by methods and techniques employing controls that are suitable to prevent damage, loss or alteration of chemical and/or physical properties.

- **Quality Assurance Records**

For each test and for all samples tested, readily retrievable records are to be prepared, which are suitable to furnish documentary evidence that qualification testing and results have been implemented and documented in conformance with all applicable requirements. Responsibility will be assigned to store and retain all such records.

Administrative System

The metal matrix neutron absorbing material qualification project plan is to be implemented within a quality assurance-based administrative system that verifies and documents attainment of the above six critical elements. Within the administrative system, there must also exist adequate provision for document control, control of non-conformances, corrective actions as well as planned and scheduled quality assurance audits which verify compliance with all applicable requirements. In actual practice, quality assurance controls of the types described above will be applied to the preparation, review, approval, implementation and verification of the test procedures cited in the appendices of this project plan.

A SEP-244-01: PROCEDURE FOR ACCELERATED CORROSION TESTING OF ALUMINUM MATRIX NEUTRON ABSORBER MATERIAL COUPONS

Scope

In support of the Aluminum Matrix Neutron Absorber Material (AMNAM) wet and dry storage qualification project, this procedure specifies the methods and techniques to be used to:

- Replicate at elevated temperature the aqueous environments typically encountered in PWR and BWR spent fuel pools.
- Expose specified numbers and particular types of AMNAM coupons for prescribed time intervals to the replicated aqueous environments.
- Remove AMNAM coupons from the test environment to detect and classify possible corrosion induced effects.
- Record pertinent data related to coupons, exposures and to environmental control.

A total of 138 AMNAM coupons will be environmentally qualified according to the procedure described herein.

Applicability

AMNAM coupons held on specially designed Teflon racks will be exposed to controlled aqueous environments in order to determine, on an accelerated basis, the susceptibility to general (uniform) and localized (pitting) corrosion. Subsequent to initial characterization of select properties, the uniquely identified coupons will be systematically placed on specially fabricated holding racks. The racks will be placed in circulating water baths containing either plain deionized water (BWR) or deionized water having 2500 ppm of boron as boric acid (PWR). Both environments will be maintained at a constant temperature of 195°F. At specified intervals (every 2000 hrs) and at the full completion of the test (8000hrs), particular coupons will be removed and subjected to post-test characterization. After final characterization, the coupons will be individually stored in a vapor corrosion inhibiting (VCI) bags.

Related Documents

- Qualification Testing for Metal Matrix and Alloy Neutron Absorber Materials for Wet and Dry Storage Applications: Main body of this report and referred to as NET-244-02 in the appendices.

- SEP-244-06 Procedure for Pre-Characterizing the Accelerated Corrosion Coupons.
- SEP-244-07 Procedure for Post-Test Characterization of the Accelerated Corrosion Coupons.
- Hach Water Analysis Procedures, for Al, B, Na, Cl, Si, pH and conductivity.
- ASTM D-1193-99 Standard Specification for Reagent Water.

Required Test Equipment and Materials

Equipment Required

1. Thermometers (2), range 0 to 110° (1°C graduation) (Scientific Products Model T2050-1 or equivalent).
2. pH Meter with up to 0.01 pH resolution (Cole-Palmer, Model MF-59002-40 or equivalent).
3. Conductivity Meter and cell (Cole-Palmer, Model MF-19810-00 or equivalent).
4. Hach Model DR/IA Colorimeter or equivalent.
5. Large volume (56 liter) Constant Temperature Utility Baths (2 required).
6. Custom fabricated Teflon coupon holding racks fitted to interior of utility baths with designated locations to accommodate particular types and numbers of *AMNAM* coupons (8 required).
7. Mixed bed demineralizer.
8. 1 liter polyethylene flasks.
9. Stainless steel rules - 12" long (2).
10. Cylindrical HDPE 15 gallon storage tank with cover and spigot (2 required)

To assure that instruments and other measuring and test equipment used for this project are properly controlled, calibrated and adjusted at specified intervals in order to maintain the specified accuracy, the following shall apply:

Calibration standards shall have certification and/or a sticker indicating the last date of calibration and the date when further calibration is required. At the time of tests, the calibration will be completed and appropriately recorded.

Materials Required

1. Deionized water per the requirements of ASTM D-1193 type IV reagent water.
2. 1 kilogram of reagent grade boric acid.
3. Hach standard test reagents for aluminum, silica, boron, sodium and chlorine.
4. Chlorine standard solution.

5. Boron standard solution.
6. Silica standard solution.*
7. Aluminum standard solution.
8. Polyethylene bags.
9. pH standard solution.
10. Conductivity standard solution.
11. Kimwipes or paper towels.
12. Disposable latex gloves.
13. Vapor Corrosion Inhibitor (VCI) Bags.

- Note: Low-concentration solution

Coupon Designation

The 138 coupons to be tested are divided into two identical sets of 69 coupons. Each set contains coupons of 7 distinct types. The number and type of coupons in each set of 69 coupons is listed in the Table A-1 below. One set of coupons will be immersed in deionized water at 195°F, and the other in borated water at the same temperature.

**Table A-1
The Number & Type of Coupons in Each Set**

Type of Coupon	Number of Coupons	
	Intermediate w/o Absorber	Maximum w/o Absorber
Mill Finished AMNAM		
General	10	10
Crevice	10	
Galvanic (bi-metallic)	9	
Weld	10	
Encapsulated	10	10

The AMNAM coupons are 2”x 4” and are inscribed in the upper right-hand corner with a unique identification number on the front side. A coupon may be of intermediate or maximum w/o absorber. The AMNAM coupons are mill finished. Variously, the coupons may be general, crevice, weld, bi-metallic galvanic or encapsulated. Data will be recorded and stored such that the coupon ID number will correspond with the specific characteristics and test history of a given coupon. For a more complete description of the coupons the reader is referred to the Project Plan: Qualification Testing for Metal Matrix and Alloy Neutron Absorber Materials for Wet and Dry Storage Applications: NET-244-02.

For coupon designation and data handling the following conventions will apply:

- Coupon ID unique 6 digit number (xyz - abc)
- B₄C Content I or M
- Surface M or C *
- Type G (general)
- C (crevice)
- B (bi-metallic)
- W (weld)
- E (encapsulated)
- S (scratched) *

- Note: Provision is made to accommodate the possibility that coupons with protective coating may be tested.

For example, an intermediate w/o absorber mill finish weld coupon with ID number 101-132 would be designated in a data table as:

Coupon ID	B ₄ C Content	Surface Finish	Coupon Type
101-132	I	M	W

Coupon Racks and Testing Sequence

Teflon holding racks have been especially designed to hold the coupons in the fluid baths and to otherwise accommodate the testing sequence. A total of 8 racks will be used to hold the 138 coupons subject to accelerated corrosion testing. Teflon has been selected owing to mechanical strength, chemical (inertness) and temperature stability (up to 500°F) as well as the fact that the material lends itself to shaping and machining. During environmental exposure, the coupons will be held in the vertical position within close tolerance groves machined into the racks. To assure adequate fluid circulation a wide open groove will be maintained below each row of coupons.

Each rack will be inscribed with the approximate testing schedule (i.e. 2000, 4000, 6000 or 8000 hours). All coupons for each of the 2000, 4000 and 6000 hour tests will be loaded on one rack. Accordingly, the rack can be removed from the bath for testing without interrupting the test. The number of each type of coupon tested at 2000, 4000 and 6000 hours are shown in Table A-2. The coupons which are scheduled for 8000 hours of testing will also be loaded on one rack. Four racks will be immersed in deionized water and four will be immersed in borated water.

**Table A-2
Number of Coupons Tested After 2000, 4000 and 6000 Hours**

Type of Coupon	Intermediate w/o absorber	Maximum w/o Absorber
Mill Finish AMNAM		
General	2	2

Crevice	2	
Galvanic (bi-metallic) Note: A	1	
Weld	2	
Encapsulated	2	2
Note A – One bimetallic coupon of each type removed at 4000 hours. The rest will be subject to PTC at 8000 hours PTC – Post-Test Characterization		

Procedure for Test Solution Preparation and Test Initiation

Procedure for Preparing Test Solutions

- a. Initiate flow of tap water through the mixed bed demineralizer directing through flow into the demin water storage tank and take a large enough sample of flow to determine chlorine and silica levels.
- b. Using the colorimeter and appropriate test procedure and reagent set determine SiO₂, and chlorine concentrations. If the silica content is less than 100 ppb and the total chlorine, aluminum and sodium contents are less than 50 ppb continue demineralizing process.
- c. Continue filling the storage vessel until it is full. During filling process, monitor the color conductivity of the treated water and the color of the resin. Replace resin cartridge if necessary.
- d. Remove samples from the storage vessel and repeat Step 7.1b. Record silica, aluminum sodium, and chlorine water on Data Sheet SEP-244-01-01.
- e. Withdraw 1 liter of demineralized water from storage vessel into a polyethylene storage flask marked with “Archive Demineralized Water”. Label the storage vessel, “PWR, Demineralized Water”. The BWR utility bath may be filled with demineralized water from the storage tank. Label the bath “BWR Environment”. Measure and record the depth of the water on Data Sheet SEP-244-01-02.
- f. Repeat steps 7.1a to 7.1 d and fill a second polyethylene storage tank with 50 liters of deionized water.
- g. Weigh 714.4 grams of reagent grade boric acid and place in a suitable vessel. Transfer boric acid to the second storage vessel containing the 50 liters of demineralized water and mix with a polyethylene paddle until the boric acid is completely dissolved.
- h. Withdraw a suitable volume of the boric acid solution and using the colorimeter and appropriate procedure and reagent set determine the boron concentration of the boric acid

solution (Note: Owing to relatively high concentration, this will require a pipette and volumetric flask for dilution so that the test fluid is within the range of the colorimeter). If the boron concentration is determined to be within ± 50 ppm of 2500 ppm boron it is acceptable for use. If it is not, repeat boron measurement. If second determination is not within 50 ppm contact the Project Manager.

- i. Withdraw 1 liter of the boric acid solution into a polyethylene flask marked "Archive Boric Acid Solution". Label the storage vessel, "PWR, Boric Acid Solution".
- j. The PWR test utility bath may now be filled with an appropriate volume of boric acid solution. Label the bath "PWR Environment". Measure and record the depth of the water on Data Sheet SEP-244-01-02. Dispose of any boric acid solution which is not required to fill the bath.

Procedure for Test Initiation

- a. Bring the filled utility baths to a temperature of 195° F and allow to stabilize for a period of 24 hours.
- b. Remove a 100 ml sample from each bath and allow the sample to cool for 1 hour to room temperature.
- c. For the BWR sample, use the appropriate equipment to measure pH, conductivity, SiO₂, aluminum, sodium and chlorine per the appropriate procedure attached. Record on Data Sheet SEP-244-01-01.
- d. For the PWR sample, use the appropriate procedure and equipment to measure pH, conductivity, SiO₂, chlorine, aluminum, and boron per the appropriate procedure attached. Record on Data Sheet SEP-244-01-01.
- e. Place the coupon racks loaded in accordance with Section 8.0 below in their appropriate test baths and record time and date on initial entry on Data Sheet SEP-244-01-03. Cover both with gabled stainless steel covers and ensure that they fit tightly to minimize evaporative losses.
- f. After 1 week at temperature, record bath temperature on data sheet below. If necessary add sufficient amounts of demineralized water to both baths to restore the bath levels to the initial level. Record water level on Data Sheet SEP-244-1-02.
- g. After 1 hour, perform steps 7.2 b through 7.2d.
- h. At intervals to be specified by the Project Manager, thereafter, repeat step 7.2f.
- i. At a frequency to be established by the Project Manager, repeat step 7.2g.
- j. At designated time intervals, remove coupons for interim and post test inspection as per Section 9.0.

Procedure for Rack Loading

- a. Select the required number of each coupon type for the 2000 hour test and layout on a clean dry surface (the coupons should be in their respective VCI bags at this point.

- b. Sequentially remove each coupon using a pair of forceps and place in a slot designated for that coupon type in the Teflon rack inscribed with 2000 hours.
- c. As each coupon is loaded record the coupon ID No. for each coupon on data sheet SEP-244-01-03.
- d. Repeat steps a.) through c.) for each of the two 2000 hour racks filling out separate data sheets SEP-244-01-03 for each rack.
- e. Repeat steps a.) through d.) for the 4000 hour and 6000 racks.
- f. For the 8000 hour racks use data sheet SEP-244-01-04 and repeat steps a.) through d.) for each of the 8000 hour racks.
- g. Coupon Removal from Test Baths for Inspection.

Procedure for 2000, 4000 and 6000 Coupon Rack Removal

- a. Carefully remove racks designated as the 2000 hour from the circulating water baths.
- b. Examine over-all appearance of racks and coupons.
- c. Record the time and date of rack removal on Data Sheet SEP-244-01-03.
- d. Using SEP-244-07 subject the coupon to post test characterization.
- e. Repeat steps a) through d) at 4000 hours and 6000 hours.

Procedure for 8000 Hour Coupon Rack Removal

- a. De-energize circulating water baths
- b. Carefully remove all racks from the circulating water bath
- c. Subject the remaining coupons post-test characterization using SEP-244-07.

Page ____ of ____

Data Sheet SEP-244-01-01
Water Chemistry Data Sheet

Check one:

BWR Bath _____

PWR Bath _____

Date	pH	Cond. μS/cm	Resistivity		Sample Volume, ml	Dilution Factor	Instrument Reading, ppm	Actual ppm	By
				Al					
				B					
				SiO ₂					
				Cl					
				Na					
				Al					
				B					
				SiO ₂					
				Cl					
				Na					
				Al					
				B					
				SiO ₂					
				Cl					
				Na					
				Al					
				B					
				SiO ₂					
				Cl					
				Na					
				Al					
				B					
				SiO ₂					
				Cl					
				Na					

Check one _____
 Boric Acid _____
 Demin Water _____

Data Sheet SEP-244-01-03

Coupon/Rack Loading Record
 Scheduled for Testing at _____ hours

Test Initiated _____
 Date: _____
 Test Terminated _____
 Time: _____

Coupon Type	Finish	B ₄ C Loading, w/o	Coupon ID
General	M	I	
General	M	I	
General	M	M	
General	M	M	
Crevice	M	I	
Crevice	M	I	
Weld	M	I	
Weld	M	I	
Encapsulated	M	I	
Encapsulated	M	I	
Encapsulated	M	M	
Encapsulated	M	M	

4000 hour coupons only

Coupon Type	Finish	B ₄ C Loading, w/o	Coupon ID
Galvanic - Ss-304	M	I	
Galvanic - In-718	M	I	
Galvanic - Zr-2	M	I	

Check one Boric Acid _____ Demin Water _____
 Data Sheet SEP-244-01-04
 Coupon/Rack Loading Record
 Scheduled for Testing at _____ hours
 Test Initiated Date: _____
 Test Terminated Date: _____
 Time: _____

Coupon Type	Finish	B ₄ C Loading, w/o	Coupon ID
General	M	I	
General	M	I	
General	M	I	
General	M	I	
General	M	M	
General	M	M	
General	M	M	
General	M	M	
Crevice	M	I	
Crevice	M	I	
Crevice	M	I	
Crevice	M	I	
Weld	M	I	
Weld	M	I	
Weld	M	I	
Weld	M	I	
Encapsulated	M	I	
Encapsulated	M	I	
Encapsulated	M	I	
Encapsulated	M	I	
Encapsulated	M	M	
Encapsulated	M	M	
Encapsulated	M	M	
Encapsulated	M	M	
Galvanic - Ss-304	M	I	
Galvanic - Ss-304	M	I	
Galvanic - Zr-2	M	I	
Galvanic - Zr-2	M	I	
Galvanic - In-718	M	I	
Galvanic - In-718	M	I	

B SEP-244-02: PROCEDURE FOR SHORT-TERM ELEVATED TEMPERATURE TESTING OF ALUMINUM MATRIX NEUTRON ABSORBER MATERIAL COUPONS

Scope

In support of the candidate Aluminum Matrix Neutron Absorber Material AMNAM wet and dry storage nuclear qualification project, this procedure specifies the methods and techniques to be used to:

- Replicate the elevated temperature environment typically encountered for short time period in dry fuel cask drying operations after fuel loading:
- Expose specified set of AMNAM coupons for a prescribed time interval to the replicated elevated temperature environment:
- Remove AMNAM coupons from the test environment to detect and classify possible thermal induced effects:
- Record pertinent data related to coupons, exposures and to environmental control.

A total of 30 AMNAM coupons will be environmentally qualified according to the procedure described herein.

Applicability

In order to determine possible susceptibility to thermally induced effects, AMNAM coupons will be time exposed to elevated temperature (900°F) in a controlled environment in a furnace. Subsequent to pre-test characterization of select properties, the uniquely identified coupons will be systematically placed in the furnace. The furnace will be purged with helium and brought to and maintained at a constant temperature of 900°F. After a period of 48 hours at temperature the coupons will be cooled to room temperature and subjected to post-test characterization. After final characterization the coupons will be individually stored in labeled polyethylene bags.

As part of the process of initial characterization, a separate group of coupons referred to, as archive coupons will be subject to destructive tensile testing. The archive coupons will not be heated, however measured mechanical properties will be compared with those determined in post-test characterization of similar coupons that were subjected to elevated temperature testing. The same archive coupons will be used for the long-term and short-term thermal exposure tests.

Related Documents

- Qualification Testing for Metal Matrix and Alloy Neutron Absorber Materials for Wet and Dry Storage Applications: Main body of this report and referred to as NET-244-02 in the appendices.
- SEP-244-08 Procedure for Precharacterization of Thermal Coupons.
- SEP-244-10 Procedure for Post Test Characterization of Thermal Coupons.

Required Test Equipment and Materials

Equipment Required:

1. Blue M muffle furnace with chamber purge vent and programmable temperature control.
2. Chromel/Alumel Thermocouples and recorder (2 minimum).
3. Helium regulator and connecting tubing.
4. 6061 Aluminum plate sized to fit furnace floor.

Materials Required:

1. Tank of pressurized helium

Coupon Designation and Test Scope

Coupon Designation

The 30 coupons to be tested comprise a set of an equal number (5 of each type) of 6 distinct types. The number and type of coupons are listed in the Table B-1 below.

**Table B-1
The Number and Type of Coupons in the Set**

Type of Coupon	Number of Coupons	
	Intermediate w/o Neutron Absorber	Maximum w/o Neutron Absorber
<i>Mill Finished</i>		
General:		
Rectangular	5	5
Tensile	5	5
Weld:		
Rectangular	5	
Tensile:	5	

Mill finish AMNAM coupons, either rectangular or tensile and either intermediate without or maximum without neutron absorber. The four resultant categories are further divided into general and weld coupons. All weld coupons are intermediate w/o neutron absorber. Each coupon is inscribed in the upper right hand corner with a unique identification number. Ten tensile coupons constitute the set of archive coupons referred to above. For a more complete description of the coupons the reader is referred to the Project Plan: Qualification Testing for Metal Matrix and Alloy Neutron Absorber Materials for Wet and Dry Storage Applications, NET-244-02.

For coupon designation and data handling the following conventions will apply:

Test Environment	STT (short-term thermal)
Coupon ID	unique 6 digit number
B ₄ C Content	I or M
Surface *	M or C
Type	T (tensile) R (rectangular)
Weld Status	W(weld) G (general), no weld

- Note: Provision is made to accommodate the possibility that coupons with protective coating may be tested.

For example, an intermediate w/o absorber mill finish welded tensile coupon with ID number 075 would be designated in a data table as:

Test Environment	Coupon ID	B₄C Content	Surface Finish	Coupon Type	Weld Status
STT	101-075	I	M	T	W

As described below, these data will be recorded on special data sheets.

Test Scope

For short-term thermal testing, the scope of pre-test and post-test characterization tests are identical. The tests are to be performed in conformity with SEP-244-08 Procedure for Pre-Characterization of Thermal Coupons and with SEP-244-10 Procedure for Post-Test Characterization of Thermal Coupons. The characterization tests are listed in the Table B-2 below.

**Table B-2
Scope of Tests for Short-Term Thermal Testing**

Test	Pre- Characterization	Post- Characterization
Visual Inspection	✓	✓
High Resolution Photography	✓	✓
Dimensions	✓	✓
Dry Weight	✓	✓
Density	✓	✓
Tensile Strength (1)	✓	✓
Yield Strength (1)	✓	✓
Elongation (1)	✓	✓
Neutron Attenuation (2)	✓	✓
Radiography (3)	✓	

Legend

1. Perform test on archive coupons and retain coupons for comparison to post-test data
2. 2 Select samples only
3. 3 Tensile weld specimens only. X-ray for weld porosity

NOTE: Prior to test exposure all coupons shall have been pre-characterized according to SEP-244-08.

Procedure for Test Performance and Data Recording

- a. Place the coupons in the furnace on 6061 aluminum plate cut to fit the floor of the furnace. The aluminum plate will serve as a thermal contact between the coupon and the furnace floor. Record coupon ID numbers on Data Sheet SEP-244-02-01 and record test environment as STT.
- b. Place thermocouples in the center of two stacks of coupons and run the leads to the recorder.
- c. Secure the furnace door and purge the furnace volume with helium. After the initial purge set helium flow rate as specified by the project manager.
- d. Turn on the furnace heating element and initiate heating. Record the time of initial heating on Data Sheet Sep-152-02-02.

- e. As the furnace approaches 900°F trim the furnace control to allow the coupons to come to equilibrium temperature at 900°F ± 25°F. Record the time on Data Sheet SEP-244-02-02.
- f. Continue to record the temperature throughout the test on the strip chart recorder.
- g. After 48 hours turn off the furnace and allow the furnace to come to room temperature. Record the date and time on Date Sheet 244-02-02.
- h. Turn off helium flow, open the furnace and remove the thermocouples.
- i. Inspect the coupons and note any anomalies on Data Sheet-244-02-02. Place each coupon in a polyethylene bag for storage until the post test characterization is performed.

C SEP-244-03: PROCEDURE FOR LONG-TERM ELEVATED TEMPERATURE TESTING OF ALUMINUM

Scope

In support of the candidate Aluminum Matrix Neutron Absorber Material (AMNAM) wet and dry storage qualification project, this procedure specifies the methods and techniques to be used to:

- Replicate the elevated temperature environment typically encountered in dry fuel cask for a period of 8000 hours.
- Expose specified set of AMNAM coupons for a prescribed time interval to the replicated elevated temperature environment.
- Remove AMNAM coupons from the test environment to detect and classify possible thermal induced effects.
- Record 30 AMNAM pertinent data related to coupons, exposures and to environmental control.

A total of 60 AMNAM coupons will be environmentally qualified according to the procedure described herein.

Applicability

In order to determine the possible susceptibility to long-term thermally induced effects, AMNAM coupons will be time exposed to elevated temperature in an air atmosphere. This is considerably more aggressive than the inert atmosphere (helium) which prevails in dry storage casks but is considered conservative in the test of limited duration. Subsequent to pre-test characterization of select properties, the uniquely identified coupons will be systematically placed in the furnace. The furnace will be brought to and maintained at a constant temperature of 750°F for 8000 hours. At intervals of 2000 hours the furnace will be cooled to room temperature and some coupons will be subject to non-destructive interim testing and returned to the furnace for additional elevated temperature conditioning. Other coupons will be removed from the furnace permanently and subject to post-test destructive characterization. Table C-1 shows the type and number of coupons tested. After final characterization the coupons will be individually stored in labeled polyethylene bags.

Table C-1
The Number and Type of Coupons in the Set

Type of Coupon	Number of Coupons	
	Intermediate w/o Neutron Absorber	Maximum w/o Neutron Absorber
<i>Mill Finished AMNAM</i>		
General:		
Rectangular	5	5
Tensile	5	5
Weld:		
Rectangular	5	
Tensile:	5	

As part of the process of initial characterization, a separate group of coupons referred to, as archive coupons will be subject to destructive tensile testing and Rockwell B or E hardness testing depending on the boron carbide loading. The archive coupons will not be subjected to elevated temperature testing, however measured mechanical properties will be compared with those determined in post-test characterization of similar coupons that were subjected to elevated temperature testing. The same archive coupons will be used to develop baseline properties for the long-term and short-term thermal tests, as well as the accelerated radiation test.

Related Documents

- Qualification Testing for Metal Matrix and Alloy Neutron Absorber Materials for Wet and Dry Storage Applications: Main body of this report and referred to as NET-244-02 in the appendices.
- SEP-244-08 Procedure for Pre-Characterization of Thermal Coupons.
- SEP-244-09 Procedure for Interim Testing of Thermal Coupons.
- SEP-244-10 Procedure for Post-Test Characterization of Thermal Coupons.

Required Test Equipment and Materials

Equipment Required:

- 1 Blue M muffle furnace with temperature control.
- 2 Chromel/Alumel Thermocouples and recorder (2 minimum).
- 3 Aluminum plate sized to fit furnace floor.

Coupon Designation and Test Scope

Coupon Designation

The 30 coupons to be tested comprise a set of an equal number (5 of each type) of 6 distinct types. The number and type of coupons are listed in the table below.

The AMNAM coupons are mill finish, either rectangular or tensile and either intermediate w/o neutron absorber or maximum w/o neutron absorber. The eight resultant categories are further divided into general and weld coupons. All weld coupons are intermediate w/o. Each coupon is inscribed in the upper right hand corner with a unique identification number. Ten tensile coupons constitute the set of archive coupons referred to above. For a more complete description of the coupons the reader is referred to the Project Plan: Qualification Testing for Metal Matrix and Alloy Neutron Absorber Materials for Wet and Dry Storage Applications, NET-244-02.

For coupon designation and data handling the following conventions will apply:

Test Environment	LTT (long-term thermal)
Coupon ID	unique 6 digit number
B ₄ C Content	I or M
Surface *	M or C
Type	T (tensile) R (rectangular)
Weld Status	W (weld) G (general) i.e. no weld

Note: Provision is made to accommodate the possibility that coupons with protective coating may be tested.

For example, an intermediate w/o B₄C absorber mill finish welded tensile coupon with ID number 175-523 would be designated in a data table as:

Test Environment	Coupon ID	B ₄ C Content	Surface Finish	Coupon Type	Weld Status
LTT	175-523	15	M	T	W

As described below, these data will be recorded on special data sheets.

Test Scope

For long-term thermal testing the scope of pre-test and post-test characterization tests are identical with the exception of the radiography which is performed on the tensile weld coupon during the pre-characterization test. The tests are to be performed in conformity with SEP-244-08 Procedure for Pre-Characterization of Thermal Coupons and with SEP-244-10

Procedure for Post Test Characterization of Thermal Coupons. The non-destructive interim tests are performed as per SEP-244-09, Procedure for Interim Testing of Thermal Coupons. The characterization tests are listed in the Table C-2 below.

**Table C-2
Scope of Tests for the Long-Term Thermal Testing**

Test	Pre-Characterization	Interim	Post-Characterization
Visual Inspection	✓	✓	✓
High-Resolution Photography	✓	✓	✓
Dimensions	✓	✓	✓
Dry Weight	✓	✓	✓
Density	✓		✓
Tensile Strength ¹	✓		✓
Yield Strength ¹	✓		✓
Elongation ¹	✓		✓
Neutron Attenuation ²	✓		✓
Radiography ³	✓		
Chemical Characterization	OPT		OPT

1 Retain archive material for comparison to post-test data.

2 Select samples only.

3 Tensile weld specimens only. X-ray radiography for weld porosity.

OPT: At the option of the project manager.

NOTE: Prior to test exposure all coupons shall have been pre-characterized according to SEP-244-08.

Procedure for Test Performance and Data Recording

- a. Place the coupons in the furnace on an aluminum plate cut to fit the floor of the furnace. The aluminum plate will serve as a thermal contact between the coupon and the furnace floor. Record coupon ID numbers on Data Sheet SEP-244-03-01 and record test environment as LTT.
- b. Place thermocouples in the center of two stacks of coupons and run the leads to the recorder.

- c. Secure the furnace door and turn on the furnace heating element and initiate heating. Record the time of initial heating on Data Sheet SEP-244-03-02.
- d. As the furnace approaches 750°F trim the furnace control to allow the coupons to come to equilibrium temperature at 750°F ± 25°F. Record the time on Data Sheet SEP-244-03-02.
- e. Continue to record the temperature throughout the test on the strip chart recorder.
- f. After approximately 2000 hours turn off the furnace and allow the furnace to come to room temperature. Record the date and time on Date Sheet 244-03-02.
- g. Remove the coupons scheduled for post test characterization and place in individual polyethylene bags until post test characterization work can be completed.
- h. Inspect the coupons scheduled for interim testing and note any anomalies on Data Sheet-244-03-02. Place each coupon in a polyethylene bag for storage until the interim test characterization is performed.
- i. Perform interim test characterization per SEP-244-09.
- j. Perform post test characterization per SEP-244-10.
- k. Repeat steps a through j until the remaining coupons have been exposed to 750° for a cumulative period of 8000 hours.

Data Sheet SEP-244-03-02

Long-Term Elevated Temperature Test Log

Record for Initial 2000 hours at 750°F:

Furnace Heating Initiated: Date: _____; Time: _____; By _____; Verified: _____

Furnace at Equilibrium at 750°F: Date: _____; Time: _____; By _____; Verified: _____

Furnace at 750°F for 2000 hrs.: Date: _____; Time: _____; By _____; Verified: _____

Furnace at Lab Temperature: Date: _____; Time: _____; By _____; Verified: _____

Record for Second 2000 hrs @ 750°F:

Date: _____; Time: _____; By _____; Verified: _____

Furnace Heating Initiated Date: _____; Time: _____; By _____; Verified: _____

Furnace at 750°F Date: _____; Time: _____; By _____; Verified: _____

Furnace at 750°F for 2000 hrs.: Date: _____; Time: _____; By _____; Verified: _____

Furnace at Lab Temperature: Date: _____; Time: _____; By _____; Verified: _____

Record for Third 2000 hrs @ 750°F:

Date: _____; Time: _____; By _____; Verified: _____

Furnace Heating Initiated Date: _____; Time: _____; By _____; Verified: _____

Furnace at 750°F Date: _____; Time: _____; By _____; Verified: _____

Furnace at 750°F for 2000 hrs.: Date: _____; Time: _____; By _____; Verified: _____

Furnace at Lab Temperature: Date: _____; Time: _____; By _____; Verified: _____

Record for Fourth 2000 hrs @ 750°F:

Date: _____; Time: _____; By _____; Verified: _____

Furnace Heating Initiated Date: _____; Time: _____; By _____; Verified: _____

Furnace at 750°F Date: _____; Time: _____; By _____; Verified: _____

Furnace at 750°F for 2000 hrs.: Date: _____; Time: _____; By _____; Verified: _____

Furnace at Lab Temperature: Date: _____; Time: _____; By _____; Verified: _____

Comments _____

D SEP-244-04: PROCEDURE FOR RADIATION TESTING OF ALUMINUM MATRIX NEUTRON ABSORBER MATERIAL COUPONS

Scope

In support of the Aluminum Matrix Neutron Absorber Material (AMNAM) nuclear qualification project, this procedure specifies the methods and techniques to be used to:

- Replicate the intensive radiation environment typically encountered in spent fuel storage pools and spent fuel casks:
- Expose specified numbers and particular types of AMNAM coupons for prescribed time intervals to the replicated radiation environment:
- Remove AMNAM coupons from the test environment to detect and classify possible radiation induced effects:
- Record pertinent data related to coupons, exposures and to environmental control.

A total of 96 AMNAM coupons will be environmentally qualified according to the procedure described herein.

Applicability

Eight packets of twelve AMNAM coupons each will be placed in a specially designed and custom fabricated canister. The canister will then be time exposed to high level gamma radiation in order to determine possible susceptibility to radiation induced effects. Subsequent to initial characterization of select properties, the uniquely identified coupons will be packaged in packets, placed in the canister and then irradiated. At specified intervals of time and at the full completion of the test, coupons will be removed and subjected to re-characterization. After final characterization the coupons will be individually stored in labeled envelopes.

The AMNAM coupons in the radiation matrix will be either intermediate without or maximum without neutron absorber. In the process of initial characterization, a separate group of AMNAM coupons, referred to, as archive coupons will be subject to destructive tensile testing. The archive coupons will not be irradiated; however, measured mechanical properties will be compared with those determined in post-test characterization of similar coupons that were irradiated. The same archive coupons will be used for the long-term and short-term thermal exposure as well as irradiation tests.

Related Documents

- Qualification Testing for Metal Matrix and Alloy Neutron Absorber Materials, for Wet and Dry Storage Applications: Main body of this report and referred to as NET-244-02 in the appendices.
- SEP-244-11 Procedure for Pre-Characterizing the Accelerated Radiation Coupons.
- SEP-244-12 Procedure for Post-Test Characterization of Accelerated Radiation Coupons.

Required Test Equipment

Equipment Required:

1. Custom fabricated *AMNAM* radiation canister
2. Aluminum wire (Alloy 1100 or Alloy 6061)
3. Boraflex dosimeter coupons (4 coupons 1” wide x 8” long)

Coupon Designation and Test Scope

Coupon Designation

The 96 *AMNAM* coupons to be tested comprise a set containing 6 distinct types of coupons. The *AMNAM* coupons will be placed in 8 packets of 12 each. The number and type of coupons in each packet are listed in the Table D-1 below.

**Table D-1
Radiation Coupon Packet Contents**

Packet No.	Rectangular		Tensile		
	Int. w/o absorber	Max w/o absorber	Int. w/o absorber	Max w/o absorber	Weld*
1	2	2	3	3	2
2	2	2	3	3	2
3	2	2	3	3	2
4	2	2	3	3	2
5	2	2	3	3	2
6	2	2	3	3	2
7	2	2	3	3	2
8	2	2	3	3	2
Totals	16	16	24	24	16
*Note: Each packet will contain one intermediate w/o and one maximum w/o tensile weld coupon.					

The AMNAM coupons are mill finish, either rectangular or tensile and either intermediate w/o or maximum w/o neutron absorber. The eight resultant categories are further divided into general and weld coupons. Each coupon is inscribed in the upper right hand corner with a unique identification number. Fourteen tensile coupons constitute the set of archive coupons referred to above. For a more complete description of the coupons the reader is referred to the Project Plan: Metal Matrix and Alloy Neutron Absorber Materials, Qualification Testing for Wet and Dry Storage Applications, NET-244-02.

For data handling the following coupon designation conventions will apply:

- Test Environment RT (accelerated radiation testing)
- Coupon ID unique 3 digit number
- B₄C Content I or M
- Surface * M or C
- Type T (tensile)
 R (rectangular)
- Weld Status W (weld)
 G (general) i.e. no weld

*Note: Provision is made to accommodate the possibility that coupons with protective coating may be tested.

For example, an intermediate w/o or maximum w/o neutron absorber mill anodized finish welded tensile coupon with ID number 101-075 might be designated in a data table as:

Test Environment	Coupon ID	B₄C Content	Surface Finish	Coupon Type	Weld Status
RT	101-075	I	M	T	W

As described below, these data will be recorded on special data sheets.

Test Scope

The accelerated irradiation testing will be conducted over a period of approximately 238 days. Prior to irradiation all coupons will be subject to pre-test characterization according to SEP-244-11, “Procedure for Pre-Characterization of the Radiation Coupons”. During the course of testing, coupon characterization will be conducted after exposure intervals shown in Table D-2 below. These tests are to be performed in conformance with SEP-244-12, “Procedure for Post-Test Characterization of Radiation Coupons”.

**Table D-2
Schedule of Coupon Packet Removal Test Reactor Irradiation**

Approximate Irradiation Time, months	Coupon Gamma Exposure, rads*	Number of Packets Removed
0.5	6.0 x 10 ⁹	1
1.0	1.2 x 10 ¹⁰	1
3.0	4.8 x 10 ¹⁰	1
5.0	7.5x10 ¹⁰	1
6.0	1.0x10 ¹¹	1
12.0	2.0x10 ¹¹	3

*Based on an exposure rate of 5 x 10⁷ rads/hour at the core face of a typical test reactor. Exposure rate to be verified via dosimetry during the initial weeks of irradiation

*Based on an exposure rate of 4.4 x 10⁹ rads/day. Exposure rate will be verified via dosimetry during the initial week of irradiation

The characterization tests are listed in the Table D-3 and Table D-4 below. Table D-3 shows the scope of tests for rectangular coupons. Table 4 shows the scope of tests for tensile coupons.

**Table D-3
Scope of Tests for Irradiated Rectangular Coupons**

Test	Pre-Characterization	Post-Characterization
Visual Inspection	✓	✓
High-Resolution Photography	✓	✓
Dry Weight	✓	✓
Density	✓	✓
Hardness	✓	✓
Neutron Attenuation ¹	✓	✓
Chemical Assay	OPT	OPT
¹ On select coupons only OPT: Optional		

**Table D-4
Scope of Tests for Irradiated Tensile Coupons**

Test	Pre-Characterization	Post-Characterization
Visual Inspection	✓	✓
High-Resolution Photography	✓	✓
Dry Weight	✓	✓
Density	✓	✓
Hardness	✓	✓
Radiography ¹	✓	
Chemical Assay	OPT	OPT
Tensile Strength	✓	✓
Yield Strength	✓	✓
Elongation	✓	✓
¹ On weld specimens only. X-ray radiography for weld porosity. OPT: Optional		

Coupon Packets

A total of eight packets each containing 12 coupons will be assembled. A packet will contain 4 rectangular and 8 tensile coupons. The contents of each packet are shown in Table D-1 above. Figure D-1 below shows the arrangement of coupons in the packet.

COUPON PACKET FOR IRRADIATION TESTING

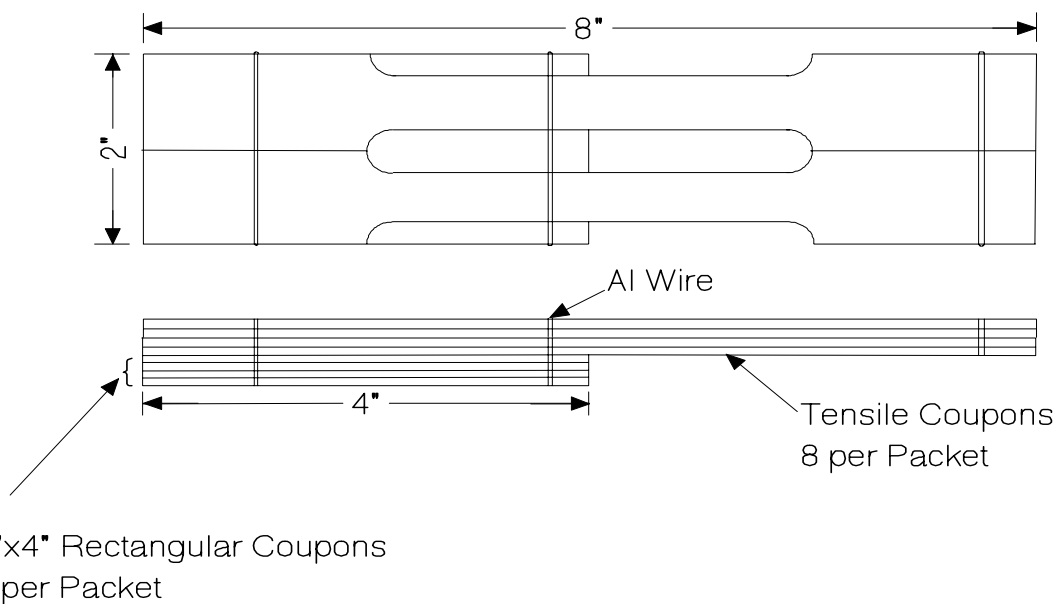

Figure D-1
Coupon Packet

NOTE: Prior to test exposure all coupons would have been pre-characterized according to SEP-244-11.

Procedure for Packet Assembly and Shipping

- a. Place coupon set on clean dry surface.
- b. For each packet select coupons types shown on Table D-1.
- c. Isolate the requisite twelve coupons on clean dry surface.
- d. Record packet number and coupon IDs on Data Sheet SEP-244-04-01.
- e. Arrange coupons as shown in Figure D-1.

- f. Position coupons so that ID number of one of the first rectangular coupons is visible when the packet is assembled.
- g. Bind packets with aluminum wire in positions shown in Figure D-1 by twisting ends and cutting excess such that placement in canister is not impeded by the wire.
- h. Record the ID number of the rectangular coupon which is visible on Data Sheet SEP-244-04-01.
- i. Repeat steps a through h for each of the seven remaining packets.
- j. Carefully load assembled packets into canister.
- k. Assure that each packet is securely positioned.
- l. Secure the lid on the canister.
- m. Package the canister in suitable shipping package.
- n. Ship package by Federal Express to the designated person at test reactor.

Procedure for Test Irradiation

- a. Record time and date of reactor startup following placement of the AMNAM canister in the radiation field of the test reactor on Data Sheet SEP-244-04-02.
- b. After one week of irradiation remove one coupon packet from the canister and record the ID number of the first rectangular coupon which is visible without disassembling the packet on Data Sheet SEP-244-04-02.
- c. Except for the first AMNAM coupon packet store the packet in the pool.
- d. Remove the four Boraflex dosimeter coupons.
- e. Secure canister lid and replace canister in the radiation field
- f. At the intervals identified in Table 2 remove the prescribed number of packets and repeat steps 8.0a through 8.0c and 8.0e above.

Note:
Do not remove packet with rectangular coupon ID <u>(later)</u> with rectangular coupon ID _____ until 238 days of irradiation

- g. After 4 coupon packets have been removed from the test reactor, package the packets and ship to the individual identified in 8.0 f above.
- h. After the last four packets have been removed from the test reactor repeat step 8.0h above.

Data Recording

As designated in Sections 7.0 and 8.0 above use Data Sheet SEP-244-04-01 to record contents of coupon packets and Data Sheet SEP-244-04-02

Packet Assembly, Data Sheet SEP-244-04-01
(Use one form per packet)

Packet Number _____

ID Number of first Rectangular Coupon _____

Enter Coupons Included in Packet

Coupon Type	Number in Packet	Coupon ID
Mill, Recta, int. w/o absorber		
Mill, Recta, max. w/o absorber		
Mill, Tens, int. w/o absorber		
Mill, Tens, max. w/o absorber		
Mill, Tens, Weld, int. w/o absorber		
Mill, Tens, Weld, max w/o absorber		

Inspected By: _____ Date: _____

Verified By: _____ Date: _____

Data Sheet SEP-244-04-02
Test Reactor Irradiation Log

Event	Date	Time	Coupon Packet ID Removed	By:
Reactor Startup After Canister Placement				
Reactor Shutdown				
Reactor Startup				
Reactor Shutdown				
Reactor Startup				
Reactor Shutdown				
Reactor Startup				
Reactor Shutdown				
Reactor Startup				
Reactor Shutdown				
Reactor Startup				
Reactor Shutdown				
Reactor Startup				
Reactor Shutdown				
Reactor Startup				
Reactor Shutdown				

E SEP-244-05: PROCEDURE FOR TESTING NEUTRON ABSORBER MATERIALS UNDER SIMULATED CASK WETTING/ HYDRO TESTING & VACUUM DRYING CONDITIONS

Scope

This procedure specifies test methods for determining whether the Aluminum Matrix Neutron Absorber Material (AMNAM) will develop blisters during cask wetting/hydro testing and vacuum drying testing.

Applicability

This procedure applies to AMNAM intended for use in dry storage casks for spent nuclear fuel.

Related Documents

- Cask Final Safety Analysis Report
- Certificate of Compliance (CoC) Document

Required Test Equipment and Material

Test equipment required:

- Vacuum Furnace
- Temperature/Process Controller for Furnace
- Vacuum pump
- Aluminum Pressure Vessels (2) with 28L Capacity
- Heating Tapes for Pressure Vessels
- Pressure Regulator
- Dual Channel Chart Recorder for Type K Thermocouples
- Chart Recorder for Type J&K thermocouples
- Balance and Standard Masses Calibrated with NIST Traceable Certificate

High-Resolution Digital Camera Material required:

- Demineralized water 100 L per test
- Boric acid (~ 350 gm per test)
- Absorbent paper towels
- Acetone
- Thread sealant

Coupon Receipt Inspection/Test Preparation

AMNAM coupons approximately 8 inches wide, 12 inches long, and of nominal thickness are to be supplied in protective packaging.

- a. Unpackage coupons and inspect for an identifying number on each coupon. If they are not individually identified select a unique ID number for each coupon and inscribe in the upper right corner with an engraver. Record this number on the receipt inspection documentation. If the coupons are longer than 12 inches, trim to this length using a shear.
- b. Inspect the coupons for cleanliness. Remove any surface dirt or foreign matter.
- c. Inspect the coupons for pre-test anomalies. Record on Data Sheet 1 and photograph all coupons (front and back sides).
- d. Weigh coupons with the calibrated balance and record weight on Data Sheet SEP-244-05-01.
- e. Measure the thickness of each coupon at the location shown in Figure E-1.

Procedure for Wetting/Hydro Simulation Test

- a. Rinse the pressure chamber with deionized water.
- b. Place AMNAM coupons scheduled for testing in the pressure chamber using a spacer rack, if necessary, to keep them separated.
- c. Fill test chamber with a boric acid solution with a concentration of boron equivalent to 2500 ppm. (see Attachment for preparation of boric acid solutions).
- d. Secure the sealing bolts on the pressure chamber.
- e. Attach lines from compressed air regulator to the chamber and adjust chamber pressure to 16 ± 1 psig. Record pressure on Data Sheet SEP-244-05-01.
- f. Bring the chamber to $100^{\circ}\text{F} \pm 2^{\circ}\text{F}$ and hold for approximately 96 hours. Record time and temperature on Data Sheet SEP-244-05-01.
- g. After the prescribed time in step f, set the programmable controller to increase the borated water temperature to $200^{\circ}\text{F} \pm 2^{\circ}\text{F}$ over 17 ± 1 hour. Record time and temperature on Data Sheet SEP-244-05-01.

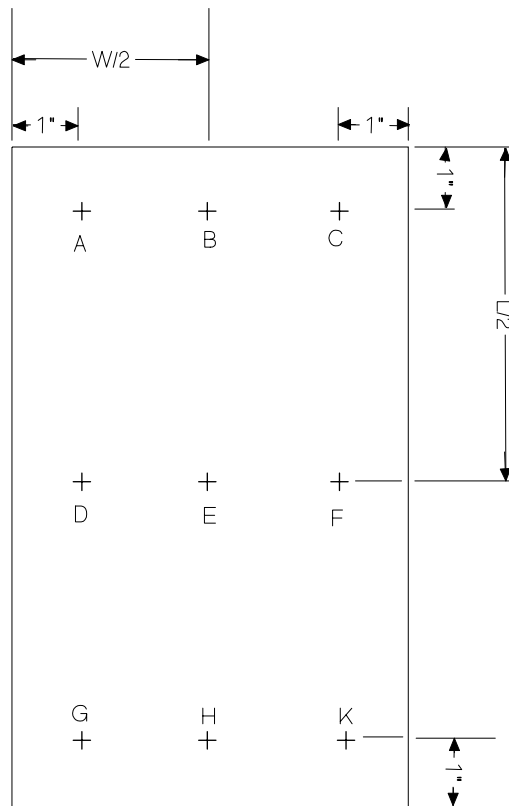

Figure E-1
Locations for Coupon Thickness Measurements

- h. Increase pressure in the chamber to 21.5 ± 1 psig for 10 minute (+ 2/-0 minutes) to simulate the hydro leak test. Record the pressure and time on Data Sheet SEP-244-05-01.
- i. Release pressure in the chamber and remove compressed air lines to the chamber.
- j. Release seal bolts and remove lid from the chamber. Remove coupons.
- k. Lay coupons on absorbent paper towels and allow surface moisture to dry.
- l. Weigh each coupon and record post test weight on Data Sheet SEP-244-05-01.
- m. Rewet each coupon for approximately 30 minutes in the borated water used for the wetting/hydro test.

Procedure for Vacuum Drying Simulation Test

- a. Immediately after step 6m, arrange the AMNAM coupons in a stack and place the stack on the furnace rack. Record the stacking order on Data Sheet SEP-244-05-02.
- b. Position one of the furnace thermocouples in the center of the coupon stack.
- c. Position the other thermocouple between the first two coupons at the bottom of the stack.
- d. Bring furnace and coupon temperature to 250°F over a period of 4 hours. Briefly open the furnace door and inspect coupon stack for blisters. Record the furnace heat-up rate, temperature and any indication of blisters.
- e. Close the furnace door, start the vacuum pump and set the automatic furnace controller. The vacuum pump setting is 3.3 ± 0.2 in H₂O. Heat up from 250°F to 550°F over a period of 10 hours. Hold at approximately 550°F for 4 hours. Record ramp parameters on Data Sheet SEP-244-05-02.
- f. After the drying cycle is complete, close bypass valve on the vacuum line and shut off the vacuum pump.
- g. Hold vacuum for 10 minutes and allow furnace to cool to room temperature. Inspect coupons for blisters and other anomalies and note on Data Sheet SEP-244-05-02.
- h. Photograph all coupons.
- i. Weigh each coupon and record coupon weight on Data Sheet SEP-244-05-03.
- j. For those coupons that have blistered, measure immersion weight and record on Data Sheet SEP-244-05-03.
- k. Review strip charts for furnace thermocouples. Note temperature of any step increases in temperature which could be indicative of the onset of blister formation.
- l. Measure coupon thickness at the location shown in Figure 1. Record on Data Sheet SEP-244-05-02.

The test conditions are summarized in Table E-1.

Data Recording

As described in Sections 6.0 and 7.0 above use Data Sheets SEP-244-05-01, SEP-244-05-02 and SEP-244-05-03 to record data for Wetting/Hydro Test Simulation, Coupon Thickness Measurements, and Vacuum Drying Test Simulation, respectively.

**Table E-1
Summary of Test Conditions for AMNAM Coupons**

Immersion Test (2500 ppm Boron)	
Time, hrs	96
Temperature, °F	100
Pressure, psig	16
Water Heat-up and Hydro Test	
Water Heat-up Time, hrs	17
End Temperature, °F	200
Ramp Pressure, psig	16
Hydro Test Pressure, psig	21.5
Hydro Test Time, minutes	10
Initial Heat-up (Dry, no Vacuum)	
Average Heat-up Rate, °F/hr	~ 35
Temperature, °F	250
Pressure, psig	Ambient
Heat-up under Vacuum	
Average Heat-up Rate, °F/hr	~ 30
Temperature, Pump on, °F	250
Final Temperature, °F	550
Time, hrs	10
Pressure, in. H ₂ O (mm Hg)	3.3 (6.2)

Export Control Restrictions

Access to and use of EPRI Intellectual Property is granted with the specific understanding and requirement that responsibility for ensuring full compliance with all applicable U.S. and foreign export laws and regulations is being undertaken by you and your company. This includes an obligation to ensure that any individual receiving access hereunder who is not a U.S. citizen or permanent U.S. resident is permitted access under applicable U.S. and foreign export laws and regulations. In the event you are uncertain whether you or your company may lawfully obtain access to this EPRI Intellectual Property, you acknowledge that it is your obligation to consult with your company's legal counsel to determine whether this access is lawful. Although EPRI may make available on a case-by-case basis an informal assessment of the applicable U.S. export classification for specific EPRI Intellectual Property, you and your company acknowledge that this assessment is solely for informational purposes and not for reliance purposes. You and your company acknowledge that it is still the obligation of you and your company to make your own assessment of the applicable U.S. export classification and ensure compliance accordingly. You and your company understand and acknowledge your obligations to make a prompt report to EPRI and the appropriate authorities regarding any access to or use of EPRI Intellectual Property hereunder that may be in violation of applicable U.S. or foreign export laws or regulations.

The Electric Power Research Institute (EPRI)

The Electric Power Research Institute (EPRI), with major locations in Palo Alto, California, and Charlotte, North Carolina, was established in 1973 as an independent, nonprofit center for public interest energy and environmental research. EPRI brings together members, participants, the Institute's scientists and engineers, and other leading experts to work collaboratively on solutions to the challenges of electric power. These solutions span nearly every area of electricity generation, delivery, and use, including health, safety, and environment. EPRI's members represent over 90% of the electricity generated in the United States. International participation represents nearly 15% of EPRI's total research, development, and demonstration program.

Together...Shaping the Future of Electricity

© 2006 Electric Power Research Institute (EPRI), Inc. All rights reserved. Electric Power Research Institute and EPRI are registered service marks of the Electric Power Research Institute, Inc.

 Printed on recycled paper in the United States of America

1013723

ELECTRIC POWER RESEARCH INSTITUTE

3420 Hillview Avenue, Palo Alto, California 94304-1338 • PO Box 10412, Palo Alto, California 94303-0813 • USA
800.313.3774 • 650.855.2121 • askepri@epri.com • www.epri.com