

# **Common Functions for Smart Inverters**

*4<sup>th</sup> Edition*

**3002008217**

---



# Common Functions for Smart Inverters

*4<sup>th</sup> Edition*

3002008217

Technical Update, December 2016

EPRI Project Manager

B. Seal

## **DISCLAIMER OF WARRANTIES AND LIMITATION OF LIABILITIES**

THIS DOCUMENT WAS PREPARED BY THE ORGANIZATION(S) NAMED BELOW AS AN ACCOUNT OF WORK SPONSORED OR COSPONSORED BY THE ELECTRIC POWER RESEARCH INSTITUTE, INC. (EPRI). NEITHER EPRI, ANY MEMBER OF EPRI, ANY COSPONSOR, THE ORGANIZATION(S) BELOW, NOR ANY PERSON ACTING ON BEHALF OF ANY OF THEM:

(A) MAKES ANY WARRANTY OR REPRESENTATION WHATSOEVER, EXPRESS OR IMPLIED, (I) WITH RESPECT TO THE USE OF ANY INFORMATION, APPARATUS, METHOD, PROCESS, OR SIMILAR ITEM DISCLOSED IN THIS DOCUMENT, INCLUDING MERCHANTABILITY AND FITNESS FOR A PARTICULAR PURPOSE, OR (II) THAT SUCH USE DOES NOT INFRINGE ON OR INTERFERE WITH PRIVATELY OWNED RIGHTS, INCLUDING ANY PARTY'S INTELLECTUAL PROPERTY, OR (III) THAT THIS DOCUMENT IS SUITABLE TO ANY PARTICULAR USER'S CIRCUMSTANCE; OR

(B) ASSUMES RESPONSIBILITY FOR ANY DAMAGES OR OTHER LIABILITY WHATSOEVER (INCLUDING ANY CONSEQUENTIAL DAMAGES, EVEN IF EPRI OR ANY EPRI REPRESENTATIVE HAS BEEN ADVISED OF THE POSSIBILITY OF SUCH DAMAGES) RESULTING FROM YOUR SELECTION OR USE OF THIS DOCUMENT OR ANY INFORMATION, APPARATUS, METHOD, PROCESS, OR SIMILAR ITEM DISCLOSED IN THIS DOCUMENT.

REFERENCE HEREIN TO ANY SPECIFIC COMMERCIAL PRODUCT, PROCESS, OR SERVICE BY ITS TRADE NAME, TRADEMARK, MANUFACTURER, OR OTHERWISE, DOES NOT NECESSARILY CONSTITUTE OR IMPLY ITS ENDORSEMENT, RECOMMENDATION, OR FAVORING BY EPRI.

**THE ELECTRIC POWER RESEARCH INSTITUTE (EPRI) PREPARED THIS REPORT.**

**This is an EPRI Technical Update report. A Technical Update report is intended as an informal report of continuing research, a meeting, or a topical study. It is not a final EPRI technical report.**

### **NOTE**

For further information about EPRI, call the EPRI Customer Assistance Center at 800.313.3774 or e-mail [askepri@epri.com](mailto:askepri@epri.com).

Electric Power Research Institute, EPRI, and TOGETHER...SHAPING THE FUTURE OF ELECTRICITY are registered service marks of the Electric Power Research Institute, Inc.

Copyright © 2016 Electric Power Research Institute, Inc. All rights reserved.

# ACKNOWLEDGMENTS

The Electric Power Research Institute (EPRI) prepared this report.

Principal Investigator

B. Seal

B. Ealey

This report describes research sponsored by EPRI.

---

This publication is a corporate document that should be cited in the literature in the following manner:

*Common Functions for Smart Inverters: 4<sup>th</sup> Edition*. EPRI, Palo Alto, CA: 2016. 3002008217.



# ABSTRACT

This document is the fourth edition of “Common Functions for Smart Inverters”. This body of work represents a decade of work by utility and technology stakeholders worldwide to define a foundation for the integration of distributed energy resources such as solar photovoltaics and energy storage. Since 2009, EPRI has been facilitating an industry collaborative initiative that is working to define common functions and communication protocols for integration of smart distributed resources with the grid. The goal is to enable scenarios in which a diversity of resources (including, photovoltaic and energy storage) in varying sizes and from varying manufacturers can be integrated into distribution circuits in a manageable and beneficial way. This requires a degree of consistency in the services and functions that these devices provide and uniform, standards-based communication protocols for their integration with utility distribution management and supervisory control and data acquisition (SCADA) systems.

The initiative has engaged a large number of individuals representing inverter manufacturers, system integrators, utilities, universities, and research organizations. The resulting work products have provided valuable input to a number of standards organizations and activities, including the National Institute of Standards and Technology (NIST) and the International Electrotechnical Commission (IEC). Participation in this activity has been open to anyone who is interested. Volunteers met by teleconference from 2009 to August 2012, discussing, defining, and documenting the first phase of proposed common functions. The process continued since address new ideas and gaps as they are identified through field evaluations and grid code developments such as IEEE 1547 and CA Rule 21. In addition, EPRI’s Energy Storage Integration Council (ESIC), SunSpec Alliance, MESA, IEC 61850, and other groups have suggested new content and corrections the previously completed work. This report provides a compiled summary of the function descriptions that these initiatives have produced thus far. Each function is presented in the form of a proposal, which is the language used by the volunteer working group. This reflects the fact that the functions are not legal standards unless and until they are adopted by a standards development organizations (SDO).

Utilities and device manufacturers are encouraged to utilize these functional descriptions to aid in the development of requirements for smart distributed resources. Even more beneficial may be the referencing of open standards that have been derived from this work, such as Distributed Network Protocol (DNP3) mapping. The process of developing a complete design specification for a smart photovoltaic, energy-storage, or other inverter-based system may be greatly simplified by taking advantage of this body of collaborative industry work. While it is always possible to independently craft new functions, or to design similar functions that work in slightly different ways, such effort does not bring the industry closer to the end-goal of off-the-shelf interoperability and ease of system integration.

## **Keywords**

Smart inverter  
Common language  
Distributed energy resources  
Standard language  
Photovoltaic  
Energy storage



# CONTENTS

<b>ABSTRACT .....</b>	<b>V</b>
<b>1 INTRODUCTION .....</b>	<b>1-1</b>
Value to Utilities .....	1-3
Report Organization and Language .....	1-3
Ongoing Development .....	1-4
<b>2 CHARACTERISTICS OF A SMART INVERTER AND SMART INVERTER FUNCTIONALITY .....</b>	<b>2-1</b>
Configuration.....	2-1
Group Level Versus Individual Level Functionality .....	2-3
Categorization of Smart Inverter Functionality .....	2-4
<b>3 OVERVIEW OF THE 2016 UPDATE.....</b>	<b>3-1</b>
<b>4 BASIC DEVICE SETTINGS AND LIMITS.....</b>	<b>4-1</b>
Scope of This Function .....	4-1
Requirements/Use Cases .....	4-1
Prior Bodies of Work .....	4-1
Proposal.....	4-1
Basic Power Settings and Nameplate Values.....	4-1
Voltage Normalization Settings .....	4-3
Real Power Ramp Rate Settings .....	4-4
<b>5 CONNECT/DISCONNECT FUNCTION.....</b>	<b>5-1</b>
Scope of This Function .....	5-1
Requirements/Use cases.....	5-1
Prior Bodies of Work .....	5-1
Proposal.....	5-1
Editor Notes .....	5-3
<b>6 LIMIT DER POWER OUTPUT FUNCTION .....</b>	<b>6-1</b>
Scope of This Function .....	6-1
Requirements/Use Cases .....	6-1
Prior Bodies of Work .....	6-1
Proposal.....	6-1
Device Ratings .....	6-1
Maximum Generation Level Function .....	6-1
<b>7 ENERGY STORAGE: DIRECT CHARGE/DISCHARGE MANAGEMENT FUNCTION.....</b>	<b>7-1</b>
Scope of This Function .....	7-1
Requirements/Use Cases .....	7-1
Prior Bodies of Work .....	7-1
Proposal.....	7-1
General Storage System Settings.....	7-1

Direct Charge Discharge Request .....	7-2
Charge/Discharge Schedules .....	7-3
<b>8 ENERGY STORAGE: PRICE-BASED CHARGE/DISCHARGE FUNCTION .....</b>	<b>8-1</b>
Scope of This Function .....	8-1
Requirements/Use Cases .....	8-1
Prior Bodies of Work .....	8-1
Proposal .....	8-1
General Storage System Settings .....	8-1
Price-Based Charge Discharge Mode .....	8-2
Price Schedules .....	8-3
<b>9 ENERGY STORAGE: COORDINATED CHARGE/DISCHARGE MANAGEMENT FUNCTION .....</b>	<b>9-1</b>
Scope of This Function .....	9-1
Requirements/Use Cases .....	9-1
Prior Bodies of Work .....	9-1
Proposal .....	9-2
Parameters from the Direct Charge/Discharge Function .....	9-2
Basic Charging Model .....	9-2
Duration at Maximum Charging and Discharging Rates .....	9-3
<b>10 FIXED POWER FACTOR FUNCTION .....</b>	<b>10-1</b>
Scope of This Function .....	10-1
Scope of This Function .....	10-1
Requirements/Use Cases .....	10-1
Prior Bodies of Work .....	10-1
Proposal .....	10-1
Defining the Power Factor Value .....	10-1
Power Factor Setting Function .....	10-2
<b>11 VOLT-VAR FUNCTION .....</b>	<b>11-1</b>
Scope of This Function .....	11-1
Requirements/Use Cases .....	11-1
Prior Bodies of Work .....	11-1
Proposal .....	11-1
Use of Configurable Volt-VAR Curves .....	11-1
Percent of Maximum Rated Apparent (VA) Power .....	11-2
Percent of Maximum Rated Reactive Power with VARs Precedence .....	11-2
Percent of Maximum Rated Reactive Power with Watts Precedence .....	11-2
Percent of Maximum Available Reactive Power, with Watts Precedence .....	11-3
Supporting Curve Hysteresis .....	11-3
Defining Valid Volt-VAR Configuration Arrays .....	11-4
Defining “Percent Available VARs,” the Array Y-Values .....	11-4
Defining “Percent Voltage,” the Array X-Values .....	11-5

Additional Parameters Affecting Volt-VAR Mode Settings .....	11-5
Modes for Volt-VAR Management .....	11-6
Summary of Communication Configuration Parameters to Support Volt-VAR Modes .....	11-6
Schedules for Volt-VAR Modes .....	11-7
<b>12 VOLT-WATT FUNCTION .....</b>	<b>12-1</b>
Scope of This Function .....	12-1
Requirements/Use Cases .....	12-1
Prior Bodies of Work .....	12-1
Proposal .....	12-1
Defining “Percent Voltage,” the Array X-Values .....	12-2
Application to Storage Systems (Two-Way Power Flows) .....	12-3
Limiting the Rate of Change of the Function .....	12-3
Using Modes for Handling of Multiple Volt-Watt Configurations .....	12-4
Scheduling Volt-Watt Modes .....	12-5
Resulting Block Diagram .....	12-5
Resulting Configuration Data .....	12-5
Interaction of this Function with the Intelligent Volt-VAR Function .....	12-7
<b>13 FREQUENCY-WATT FUNCTION .....</b>	<b>13-1</b>
Scope of This Function .....	13-1
Requirements/Use Cases .....	13-1
Prior Bodies of Work .....	13-1
Proposal .....	13-2
Frequency-Watt Function 1 .....	13-2
Frequency-Watt Function 2 .....	13-3
Configuration Data .....	13-6
Emergency Mode .....	13-8
Relative Prioritization of Modes .....	13-8
<b>14 WATT-POWERFACTOR FUNCTION .....</b>	<b>14-1</b>
Scope of This Function .....	14-1
Requirements/Use Cases .....	14-1
Prior Bodies of Work .....	14-1
Proposal .....	14-1
<b>15 PRICE OR TEMPERATURE DRIVEN FUNCTIONS .....</b>	<b>15-1</b>
Scope of This Function .....	15-1
Requirements/Use Cases .....	15-1
Prior Bodies of Work .....	15-1
Proposal .....	15-1
<b>16 LOW/HIGH VOLTAGE RIDE-THROUGH FUNCTION .....</b>	<b>16-1</b>
Scope of This Function .....	16-1
Requirements/Use Cases .....	16-1

Prior Bodies of Work .....	16-2
L/HVRT Proposal .....	16-2
Interpreting the Voltage-Time Curves .....	16-5
Defining Voltage in Three Phase Systems.....	16-5
Pre-Clearing Behavior During Voltage Events .....	16-5
Defining Parameters for Reconnect Behavior .....	16-6
VAR Support During High and Low Voltage Events .....	16-8
<b>17 LOW/HIGH FREQUENCY RIDE-THROUGH FUNCTION.....</b>	<b>17-1</b>
Scope of This Function .....	17-1
Requirements/Use Cases .....	17-1
Prior Bodies of Work .....	17-1
L/HFRT Proposal .....	17-2
Interpreting the Frequency-Time Curves .....	17-4
Pre-Clearing Behavior During Frequency Events .....	17-5
Defining Parameters for Reconnect Behavior .....	17-5
Special Watt Behaviors During High and Low Frequency Events.....	17-8
<b>18 DYNAMIC REACTIVE-CURRENT SUPPORT FUNCTION .....</b>	<b>18-1</b>
Scope .....	18-1
Requirements/Use Cases .....	18-1
Prior Bodies of Work .....	18-1
Proposal .....	18-2
Event-Based Behavior .....	18-3
Alternative Gradient Shape .....	18-4
Blocking Zones.....	18-4
Relationship to the Static Volt-Var Function.....	18-5
Dynamic Reactive Current Support Priority Relative to Watts .....	18-5
Settings to Manage This Function.....	18-6
<b>19 DYNAMIC REAL-POWER SUPPORT .....</b>	<b>19-1</b>
Scope of This Function .....	19-1
Requirements/Use Cases .....	19-1
Prior Bodies of Work .....	19-1
Proposal .....	19-1
Real Power Smoothing .....	19-1
Limitations of the Function .....	19-2
Settings to Manage This Function.....	19-3
<b>20 DYNAMIC VOLT-WATT FUNCTION .....</b>	<b>20-1</b>
Scope of This Function .....	20-1
Requirements/Use Cases .....	20-1
Prior Bodies of Work .....	20-1
Proposal .....	20-1

Limitations of the Function .....	20-2
Settings to Manage This Function.....	20-2
<b>21 PEAK POWER LIMITING FUNCTION .....</b>	<b>21-1</b>
Scope of this Function.....	21-1
Requirements/Use Cases .....	21-1
Prior Bodies of Work .....	21-1
Proposal.....	21-1
Limitations of the Function .....	21-2
Point of Reference for Power Limiting.....	21-3
Settings to Manage This Function.....	21-3
<b>22 LOAD AND GENERATION FOLLOWING FUNCTION.....</b>	<b>22-1</b>
Scope of This Function .....	22-1
Requirements/Use Cases .....	22-1
Prior Bodies of Work .....	22-1
Proposal.....	22-1
Load Following .....	22-1
Generation Following .....	22-2
Allowing for Proportional Load/Generation Following .....	22-3
Limitations of the Function .....	22-3
Point of Reference for Load/Generation Following .....	22-3
Settings to Manage This Function.....	22-4
<b>23 DER SETTINGS TO MANAGE MULTIPLE GRID CONFIGURATIONS (INCLUDING ISLANDING).....</b>	<b>23-1</b>
Definitions .....	23-1
Scope of This Function .....	23-1
Requirements/Use Cases .....	23-2
Prior Bodies of Work .....	23-2
Proposal.....	23-2
Multiple Settings Groups .....	23-3
Manufacturer Choice.....	23-4
Writing and Activating Settings Groups.....	23-4
Parameters to Manage This Function .....	23-5
Determining Active Settings Group .....	23-7
Managing Isochronous/Droop Modes and Reconnection .....	23-8
<b>24 WATT-VAR FUNCTION .....</b>	<b>24-1</b>
Scope of This Function .....	24-1
Requirements/Use Cases .....	24-1
Prior Bodies of Work .....	24-1
Proposal.....	24-1
Defining Valid Volt-Watt Configuration Arrays .....	24-2
Defining Reactive Power, the Array Y-Values.....	24-2

Percent of Maximum Rated Apparent (VA) Power.....	24-2
Percent of Maximum Rated Reactive Power with VARs Precedence.....	24-3
Defining Active Power, the Array X-Values.....	24-3
Additional Parameters Affecting Watt-VAR.....	24-3
Editor's Notes.....	24-3
<b>25 GUIDELINES FOR PRECEDENCE OF SETTINGS.....</b>	<b>25-1</b>
Settings Affecting Watt Output.....	25-1
Settings Affecting VAR Output.....	25-2
<b>26 STATUS MONITORING POINTS.....</b>	<b>26-1</b>
State of Charge (Energy Storage Systems).....	26-4
Operation Regions for Energy Storage Systems.....	26-6
Applications for the Types of State of Charge.....	26-8
Editor's Notes.....	26-9
<b>27 EVENT LOGGING AND REPORTING.....</b>	<b>27-1</b>
Scope.....	27-1
Requirements/Use Cases.....	27-1
Proposal.....	27-1
<b>28 TIME ADJUSTMENT FUNCTION.....</b>	<b>28-1</b>
<b>29 CONCLUSIONS.....</b>	<b>29-1</b>
<b>A FUTURE TOPICS FOR DISCUSSION.....</b>	<b>A-1</b>
Accuracy and Sampling Rate.....	A-1
Access Permissions.....	A-1
Reconnection Process.....	A-1
Addition of Alarms.....	A-1
Scheduling of Functionality for Storage Systems.....	A-1
Ramp Times and Ramp Rates.....	A-1
Referenced ECP.....	A-1
Constant VARs Function.....	A-2

# LIST OF FIGURES

Figure 1-1 The Relationship Between Functions, Information Models, Protocols, Grid Codes, and Compliance Testing .....	1-2
Figure 2-1 Example configuration of a residential storage system with net metering .....	2-2
Figure 2-2 Example of point of common coupling (PCC), electrical connection point (ECP), and point of plant control (PPC) for a large scale solar/storage site with outside communications to each inverter .....	2-2
Figure 2-4 Example of point of common coupling (PCC), electrical connection point (ECP), and point of plant control (PPC) for a large scale solar/storage site with outside communications to a site controller .....	2-3
Figure 2-5 Categorization of smart inverter functionality – control drivers .....	2-5
Figure 2-6 Categorization of smart inverter functionality – purposes .....	2-5
Figure 3-1 The groups that helped influence the 2016 update to the Common Functions report .....	3-1
Figure 4-1 Basic power settings illustration .....	4-2
Figure 4-2 Offset voltage illustration .....	4-3
Figure 5-1 Example DER diagram .....	5-2
Figure 6-1 Example maximum generation settings .....	6-2
Figure 6-2 Example function settings .....	6-3
Figure 9-1 Storage system model: time-base .....	9-2
Figure 9-2 Storage system model: SOC-base .....	9-3
Figure 9-3 Example of using the duration at maximum discharge rate .....	9-6
Figure 10-1 IEC and IEEE power factor sign conventions .....	10-2
Figure 11-1 Example array settings to describe desired volt-VAR behavior .....	11-1
Figure 11-2 Example of both percent of maximum rated apparent (VA) power and percent of maximum rated reactive power with VARs precedence .....	11-2
Figure 11-3 Example of percent of maximum rated reactive power, with watt precedence .....	11-3
Figure 11-4 Example of percent of maximum available reactive power, with watt precedence .....	11-3
Figure 11-5 Example array settings with hysteresis .....	11-4
Figure 11-6 Illustration of VAR output varying inversely with watt output .....	11-5
Figure 12-1 Example configuration curve for maximum watts vs. voltage .....	12-2
Figure 12-2 Example configuration curve for maximum watts absorbed vs. voltage .....	12-3
Figure 12-3 Time domain response of first order low pass filter .....	12-4
Figure 12-4 Overall functional block diagram .....	12-5
Figure 12-5 Example settings for volt-VAR and volt-watt modes .....	12-7
Figure 12-6 Inverter output with PV panel output at 100% .....	12-8
Figure 12-7 Inverter output with PV panel output at 80% .....	12-8
Figure 13-1 Frequency-watt function 1 visualization .....	13-3
Figure 13-2 Example of a basic frequency-watt mode configuration .....	13-3
Figure 13-3 Example array settings with hysteresis .....	13-4
Figure 13-4 Example of an asymmetrical hysteresis configuration .....	13-5
Figure 13-5 Example array configuration for absorbed watts vs. frequency .....	13-6
Figure 13-6 Example configuration for reversing sign on $P_{\text{ABSORBED}}$ limit .....	13-6
Figure 14-1 Example watt – power factor configuration .....	14-2
Figure 16-1 An example concept of the different zones. ....	16-3
Figure 16-2 Example low/high voltage ride-through curve .....	16-4
Figure 16-3 Voltage event reconnect example, showing the use of all three optional parameters .....	16-6

Figure 17-1 The example of the different zones. ....	17-3
Figure 17-2 Example low/high voltage ride-through curve.....	17-4
Figure 17-3, Frequency event reconnection example, showing the use of all three optional parameters.....	17-6
Figure 18-1 Dynamic reactive current support function, basic concept .....	18-2
Figure 18-2 Delta-voltage calculation .....	18-3
Figure 18-3 Activation zones for reactive current support.....	18-3
Figure 18-4 Alternative gradient behavior, selected by ArGraMod .....	18-4
Figure 18-5 Settings to define a blocking zone.....	18-5
Figure 19-1 Smoothing function behavior .....	19-2
Figure 20-1 Dynamic volt-watt function behavior .....	20-2
Figure 21-1 Example peak power limiting waveform .....	21-2
Figure 21-2 Examples of practical limitations – watt limit (left) and energy storage capacity limit (right) .....	21-2
Figure 21-3 Example points of reference for power limiting.....	21-3
Figure 21-4 An example implementation of the peak power limiting function for an energy storage system.....	21-5
Figure 21-5 An example implementation of the load and generation following function for an energy storage system.....	21-6
Figure 22-1 Example load following arrangement and waveform.....	22-2
Figure 22-2 Example generation following arrangement and waveform.....	22-2
Figure 23-1 Island diagram .....	23-1
Figure 23-2 Illustration of multiple settings groups .....	23-3
Figure 23-3 Reading, writing and activating settings groups .....	23-5
Figure 23-4 Determining the active settings group .....	23-7
Figure 23-5 Isochronous vs. droop watt behaviors relative to frequency.....	23-9
Figure 23-6 Isochronous vs. droop var behaviors relative to voltage .....	23-9
Figure 24-1 Example watt-VAR array .....	24-1
Figure 24-2 Example watt-VAR array where the curve does not extend the full width of the inverter’s active power operating range .....	24-2
Figure 26-1 State of charge – actual and usable energy and their associated parameters.....	26-5
Figure 26-2 The different operating region for energy storage systems .....	26-7

# LIST OF TABLES

Table 4-1 Basic power and nameplate settings .....	4-2
Table 4-2 Voltage normalization settings .....	4-3
Table 4-3 Real power ramp rate <sup>2</sup> setting .....	4-4
Table 5-1 Precedence of commands on inverters that support both virtual and physical disconnects .....	5-2
Table 9-1 Parameters for coordinated energy storage management .....	9-4
Table 11-1 Summary configuration data for the intelligent volt-VAR modes function .....	11-7
Table 12-1 Summary configuration data for one volt-watt mode .....	12-6
Table 13-1 Frequency-watt function 1 settings .....	13-2
Table 13-2 Summary configuration data for each frequency-watt function (per mode) .....	13-7
Table 16-1 Example array for L/HVRT array .....	16-4
Table 16-2 Voltage event reconnect parameters .....	16-6
Table 17-1 Example array for L/HVRT array .....	17-3
Table 17-2 Additional reconnect parameters involving frequency .....	17-6
Table 17-3 Related parameters already defined in the L/HVRT function .....	17-7
Table 18-1 Dynamic reactive current mode control .....	18-5
Table 18-2 Settings for dynamic reactive current function .....	18-6
Table 19-1 Real power smoothing function settings .....	19-3
Table 20-1 Dynamic volt-watt function settings .....	20-2
Table 21-1 Peak power limiting function settings .....	21-4
Table 22-1 Settings for the load and generation following function .....	22-4
Table 23-1 Example use cases .....	23-2
Table 23-2 Data excluded from settings groups .....	23-4
Table 23-3 Settings for managing multiple grid configuration .....	23-6
Table 23-4 Isochronous/droop setting .....	23-8
Table 25-1 Precedence of watt related functions .....	25-1
Table 25-2 Precedence of VAR Related Functions .....	25-2
Table 26-1 Status points .....	26-1
Table 27-1 Standard event codes .....	27-3



# 1

## INTRODUCTION

The Common Functions for Smart Inverters report is a summary of functional descriptions for smart inverter functions. It was created collaboratively with over 600 industry stakeholders between 2008 and 2016. The report contains their recommendations to the industry. It has become a foundational document that guides the industry on smart inverter functionality and how the information for the functions are communicated. The findings captured in the Common Functions for Smart Inverters report can be found in all smart inverter standards and specifications including DNP3, SEP2, IEC 61850, SunSpec, and MESA but also grid codes across the world.

The report started as a foundation but now we are finding that grid codes and various protocols have started looking to expand the functionality beyond what is captured in this document. This document is a reference point for the industry and is a tool to promote uniformity and interoperability across smart inverter protocols.

It should be noted that the content of this document is not a standard or a spec but technical description that captures the recommendations of the 600 people involved in its releases. The true value of this report is that information models, protocols, and grid codes can all rally behind a single definition of functionality. This is much simpler than if developed independently. It describes the function in plain-English and is filled with examples, use-cases, and prior bodies of work.

The list of smart inverter functionality is broad. There are a wide range of use-cases for smart inverters and each can have variants that are tuned for that specific use-case. However, this is not necessary and often overly complex. The better approach is to create the smallest set of functions that still allow for the current use-cases to be realized. Each change is evaluated and those deemed architecturally significant – adding capabilities not available using other functions – should be considered. This approach requires regular review of these functions, adding and updating the list as the industry learns from field deployments and new use-cases arise.

The genesis of this body of work dates to 2009, when EPRI began working with a number of utilities doing large scale Smart Grid demonstrations. These demonstrations were focused on the deployment of Distributed Energy Resources (DER) and the communication integration of these resources with the utility. Many of these projects involved the integration of inverter-based systems, such as solar photovoltaic and energy storage systems, including diverse sizes and manufacturers.

As planning for these projects and associated vendor engagements began, two things became evident:

1. There were no common, standards-based communication protocols that would allow multiple vendors products to be integrated in a consistent and manageable way.
2. There was no common view of the specific functionality, or services, that these products would provide.

The second of these was found to be far more significant. Although manufacturers all provided Smart Grid or grid-supportive functionalities, each did so in different or proprietary ways, making a system of diverse resources unmanageable. For example, every inverter maker offered some form of VAR support, but lacking any standard, each provided the support in a different way. These product providers understood that a common approach was needed and as a group have been very active and supportive of this work throughout.

EPRI worked together with the Department of Energy, Sandia National Laboratories, and the Solar Electric Power Association to form a collaborative team to facilitate this initiative. Several face-to-face workshops have been conducted, and a focus-group of volunteers have met every 1-2 weeks over a two-year period to discuss, debate, and develop a proposed set of common approaches to a range of high-value functions. Creating a set of standard DER functions formed the foundation for building information models, protocols, grid codes, and compliance tests. This document compiles all of the smart inverter work so far.

In 2016 the Common Functions for Smart Inverters was revised by a stakeholder holder group focused on energy storage devices. Work to date had mostly focused on solar inverters while keeping the basic functionality of energy systems in mind. Though the previous work captured many important energy storage functions there were areas for expansion. In this effort EPRI created a public, collaborative team through EPRI's Energy Storage Integration Council. Representatives from manufacturers, utilities, Independent System Operators (ISOs), and trade groups participated in the effort. The group sought to use the grid services that energy storage systems could provide to identify any gaps in functionality. In addition to this approach the group pulled in feedback from standards and specifications that were actively exploring advancements to smart inverter functionality. This included work on the IEC-61850 standard and work on specifications including SunSpec and MESA. Also included was recent work on grid codes including IEEE Standard 1547 and the subsequent compliance testing of inverters in UL 1741 SA and IEEE Standard 1547.1. The group reviewed 1547 and 1741 to ensure that the Common Functions for Smart Inverters included all the necessary information.

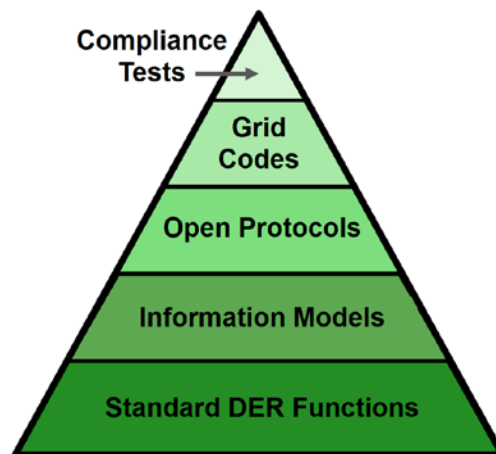

**Figure 1-1**  
**The Relationship Between Functions, Information Models, Protocols, Grid Codes, and Compliance Testing**

Though this document has been on the cutting edge of smart inverter functionality there are some protocols and grid codes that are exploring new functionality. As these new requirements are finalized in grid codes such as IEEE Standard 1547 and Rule 21 this document will continue to be important. Figure 1-1 helps explain this. The common functions can be found at the bottom of the pyramid because all functionality builds upon the definitions of standard DER functions. Without these definitions users do not know what data needs to be represented in the information models. If the information models are missing these relationships the protocols will not capture how to transmit them. If protocols do not support the functions, then products will be unavailable to meet the requirements of the grid codes. Industry Impact

This collaborative activity has taken place at an ideal time, as breakthroughs in both PV and energy storage have heightened the potential for their deployment in large scales and high penetration levels. In addition, the period has been marked by a focus on standards and protocols for integration, as exemplified by the work of the National Institute of Standards and Technology (NIST) in the United States and activities in the Institute of Electrical and Electronic Engineers (IEEE) and The International Electrotechnical Commission (IEC).

As a result, this work has been a useful and significant contribution to several standards groups and activities. The common functions support use cases collected by the NIST Priority Action Plan (PAP) 07, have provided technical input into work in the IEC TC57 WG17 and IEEE 1547.8, and have been or are being mapped into the DNP3, SEP2.0, and ModBus protocols.

## **Value to Utilities**

Utilities may utilize these functional descriptions to aid in the development of requirements for smart distributed resources. Wherever common approaches such as these can be referenced, rather than individually documenting similar functions, opportunity for interoperability is enhanced, and the ability to provide standards-based communication support is more likely.

## **Report Organization and Language**

This collection of functions was discussed and developed sequentially by a volunteer focus group. Prior to compilation in this report, each function was documented and reviewed separately. Each function is presented in an individual chapter herein, each following a similar format. As a result of this merging of what began as separate documents, certain explanatory text in the beginning of each chapter may be similar or repetitive.

Each function, or function group, is described in the form of a proposal, which is the terminology used by the volunteer working group. This reflects the fact that the functions are not legal standards unless and until they are adopted by a Standards Development Organization (SDO).

Throughout these descriptions, it may be noted that specific technical details, such as numerical scaling, variable types, and text formats are omitted. This is because each protocol into which these functions may be mapped is anticipated to have certain formats and approaches that are natural and native to that protocol. The intent here is to provide a uniform functional behavior across multiple environments, without being overly prescriptive and requiring abnormal handling of data. As an example, consider that a single feeder could have a few large DER integrated via the utility's SCADA system, and a larger number of smaller systems integrated via commercial building networks or residential home area networks. Multiple communication protocols might

be used in each of these environments, but a uniform and manageable resource represented by all these devices might be presented to a distribution manager or management system.

In their original format, each chapter herein contained an introductory statement such as this:

*This proposal is for the Phase X Smart Inverter Communication Project, for the \_\_\_\_\_ Function. This initiative is defining a toolkit of functions that are being defined using a standardized language which can then be mapped into open protocols.*

*None of the functions being described through this initiative are considered “mandatory” from an implementation perspective – actually requiring certain functions to be implemented is the purview of regulators and of the purchasers of systems. The works into which this function will be added should state that “if a function is to be implemented, then it should be implemented according to these specifications”.*

The participants in the Smart Inverter Communication Initiative elected to use a Phased approach. The full scope of defining common functions for smart inverters was recognized to be very extensive, so in the interest of finishing high-priority things in a timely fashion, the project has been executed in a series of Phases. In the chapters of this report, references to “Phase 1” or “Phase 2” may be noted in this regard.

## **Ongoing Development**

At the time of this publication, the Smart Inverter Communication Initiative is no longer active but other groups have been picking up where they left off. EPRI’s Energy Storage Integration Council (ESIC), SunSpec, MESA, IEEE P1547 Working Group, and IEC 61850 are all meeting regularly to develop new content and to correct errors and gaps identified in previously completed work.

The smart inverter landscape is rapidly expanding so EPRI recommends that prior to using this body of work for reference in specific development projects that EPRI be contacted to determine whether any changes or updates have been made.

# 2

## CHARACTERISTICS OF A SMART INVERTER AND SMART INVERTER FUNCTIONALITY

Understanding smart inverter functionality requires basic knowledge of the technologies behind them. Smart inverters include any inverter based generation where DC is covered into AC and provided to the grid. This includes solar, energy storage, wind, and electric vehicles. This document focuses on solar and energy storage but many of the functions apply to the other inverter based technologies. It is important to understand this when reading the document because each of the technologies can have their own unique function set – like the Energy Storage Charge/Discharge Function for energy storage systems – or specific attributes that must be considered for a technology – like how storage and electric vehicles can both charge and discharge. Because the groups who created these functions were focused on only solar and storage it is possible there will be gaps or ambiguities for other technologies.

### Configuration

The configuration of a smart inverter, how they connect to the grid, and their reference measurements are important for understanding how each of the functions described below will behave at a particular site. Depending on the configuration of a smart inverter, the location where each function has control will vary. Stakeholders have discussed Point of Common Coupling (PCC) and Electrical Connection Point (ECP) in relation to smart inverter functionality however they do not have an impact on the functional descriptions below. The functions are only relevant at the Point of Plant Control (PPC).

The Point of Plant Control is the point where the system and smart inverter function has control. This term was introduced to mitigate some confusion stemming from the different configurations of larger scale solar and energy storage systems. An energy storage system will be used in the following examples to help explain the Point of Plant Control.

In a residential, net-metered application the electrical connection point of the system is likely where the inverter connects to the residential panel. (Figure 2-1) The inverter's output will impact the distribution system downstream of this point however this is the point where the inverter and the smart inverter function can directly reference and control.

The case is a bit more complex in a commercial application where multiple smart inverters and devices may be located behind a single point of common coupling. In the commercial examples (Figure 2-2 and Figure 2-3), the system comprises of five energy storage systems and a large photovoltaic array. Each system has its own inverter and a unique electrical connection point. The Point of Plant Control will fall at one of two places.

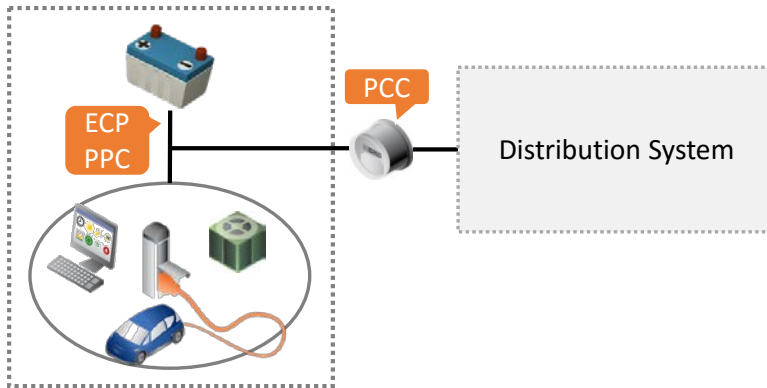

**Figure 2-1**  
**Example configuration of a residential storage system with net metering**

In the first example (Figure 2-2) each inverter has communications capabilities and built-in metering. When communicating with the individual inverters the point of plant control is the point where the device connects to the rest of the site, likely the electrical connection point. The key is that the operator is controlling each individual inverter so the smart inverter functions will control the output of each inverter at its connection point to the site.

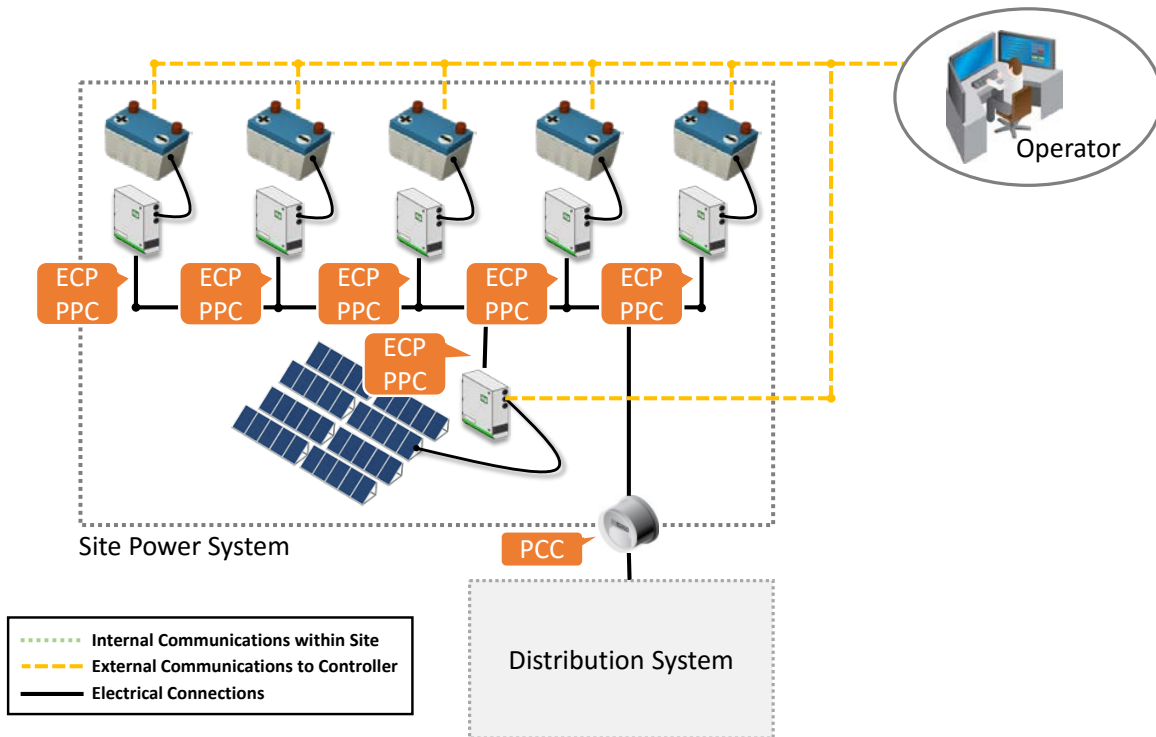

**Figure 2-2**  
**Example of point of common coupling (PCC), electrical connection point (ECP), and point of plant control (PPC) for a large scale solar/storage site with outside communications to each inverter**

In a second commercial example (Figure 2-3) each inverter is controlled by centralized controller that controls the entire site (plant controller). In this case the Point of Plant Control is located at the entrance of the site because even though data may be available on each inverter through the controller, the controller operates the site as a whole with each inverter contributing to the net

impact of the site. The key is that the system operator is controlling the plant controller, not the individual inverters so each function will operate at the controller level and will control the output of the site as a whole.

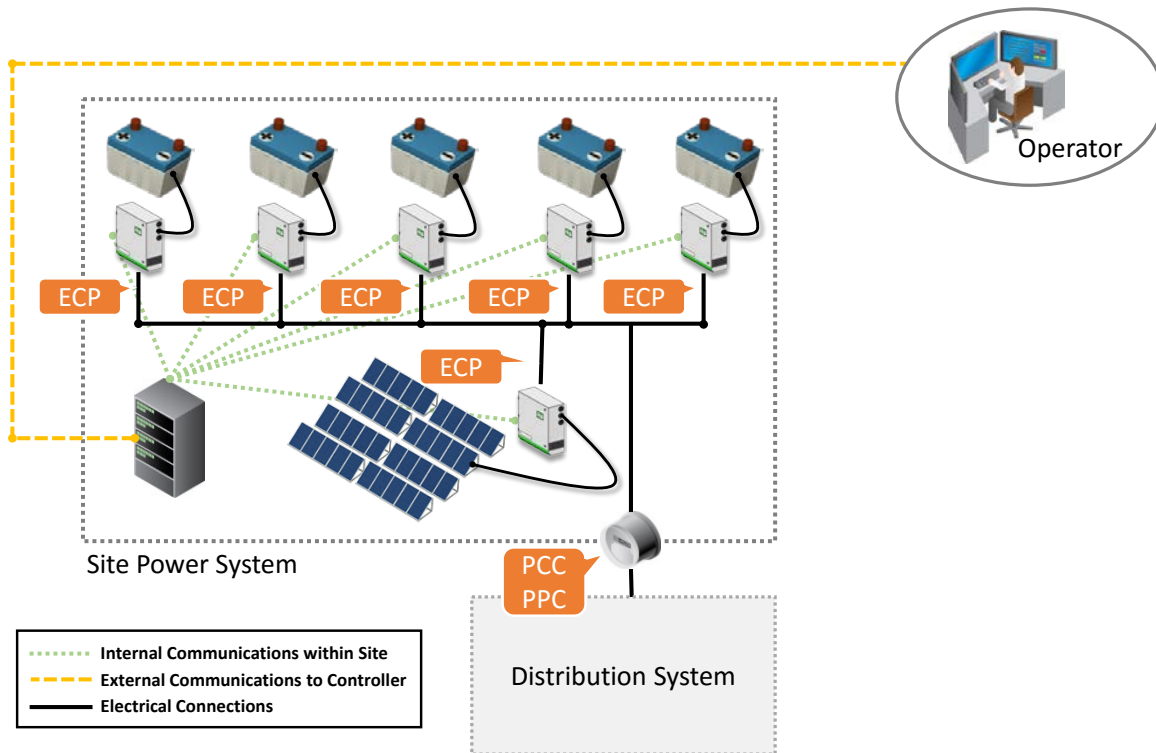

**Figure 2-3**  
**Example of point of common coupling (PCC), electrical connection point (ECP), and point of plant control (PPC) for a large scale solar/storage site with outside communications to a site controller**

It is important to note that all inverters behind one Point of Common Coupling have a common reference voltage, but may differ in the voltage between their own Electrical Connection Point and the Point of Common Coupling due to instrumentation errors or voltage shifts within a plant.

### Group Level Versus Individual Level Functionality

A reader should also understand the difference between group level and individual level functions. Group level functions control a set of individual inverters. An individual level function controls a single inverter. Functionality in this report is on the individual system level.

Systems may be comprised of multiple components, a mixture of energy storage and solar, and may have a large footprint at a site. When more than one of these systems are aggregated together they form a group. The Common Functions for Smart Inverters does not describe group functionality but this topic is addressed in EPRI’s “Common Functions for DER Group Management”<sup>1</sup>. The difference between group and individual system controls is that group level functions are looked at an aggregate level. A group level function would be accepted not by a device but by an aggregator or other entity. The entity would then create a plan on how to meet

<sup>1</sup> *Common Functions for DER Group Management, Third Edition*. EPRI, Palo Alto, CA: 2016. 3002008215.

the request based on the Distributed Energy Resources (DER) available and their current operating states and then dispatch individual level functions to each device to satisfy the group level function.

### **Categorization of Smart Inverter Functionality**

A final item that helps with understanding smart inverter functionality is the categorization of smart inverter functions. Functions can be divided into different categories depending on 1) the drivers of their control and 2) their purpose.

The control drivers can be divided into three high level categories with a total of five sub categories (Figure 2-4).

- **Functions Driven by an Operator:** These require direct interaction with an operator. Two subcategories.
  - **Basic Functions:** These functions are basic operations required for an inverter. It includes connecting or disconnecting an inverter to the grid, collecting status monitoring points, or retrieving event logs. The functions tend to support other functions by providing the operator with tools to understand how the inverter is behaving.
  - **Direct Control:** These functions allow an operator to set an output power, change power factor of an inverter, or manually control the charging and discharging of an energy storage system. The inverter stays in this state until the operator changes it.
- **Autonomous Functions:** These functions allow the inverter to make decisions on their own once an operator has provided the inverter with operating parameters. The inverter collects data from measurements at its point of plant control and acts on it. Examples of these functions are curve based functions. A function may ask an inverter to decrease its power output as voltage rises on the distribution system. No subcategories.
- **Functions Driven by Independent Variable:** These are very similar to Autonomous Functions. The key difference is that data is not collected at the electrical connection point but instead fed to the inverter from some remote data stream. Two subcategories.
  - **Electrical Data:** Electrical data is fed to the inverter and the inverter reacts to it. This is typically from a load or generator the inverter has been asked to follow but it can also be the point of common coupling or other bellwether point on the grid.
  - **Indirect Control:** Supplemental data is fed to the inverter and the inverter reacts to it. This data is not electrical but instead pricing, temperature, or time based.

Functions Driven by an Operator		Autonomous Functions	Functions Driven by Independent Variables	
Basic Functions	Direct Control	ECP Dependent	Electrical Dependent	Indirect Control
Basic Device Settings And Limits	Limit DER Power Output Function	Volt-watt Function	Peak Power Limiting Function	Battery Storage: Price-based Charge/ Discharge Function
Connect/Disconnect Function	Battery Storage: Direct Charge/Discharge Management Function	Frequency-watt Function	Low/High Voltage Ride-Through Requirements	Price Or Temperature Driven Functions
Status Monitoring Points	Fixed Power Factor Function	Watt-Power Factor Function	Low/High Frequency Ride-Through Requirements	Battery Storage: Coordinated Charge/ Discharge Management Function (time)
Event Logging And Reporting		Volt-Var Function	Dynamic Real-Power Support	
Der Settings To Manage		Dynamic Reactive Current Support Function	Load And Generation Following Function (Load or Gen Meter)	
Multiple Grid Configurations (Including Islanding)				
Time Adjustment Function				
		Watt-Var Function		

**Figure 2-4**  
**Categorization of smart inverter functionality – control drivers**

The next categorization of functions is based on their purpose. There are a total of five different categories.

- **Monitoring and Scheduling:** These are basic functions that allow an operator to make adjustments and collect information from the inverter.
- **Frequency Support:** These functions provide frequency support to the grid.
- **Real Power Support:** These functions provide real power support to the grid.
- **Power Factor Support:** These functions provide VAR support to the grid.
- **Voltage Support:** These functions provide voltage support to the grid.

Monitoring and Scheduling	Frequency Support	Real Power Support	Power Factor Support	Voltage Support
Basic Device Settings And Limits	Frequency-watt Function	Limit DER Power Output Function	Fixed Power Factor Function	Dynamic Volt-watt Function
Connect/Disconnect Function	Low/High Frequency Ride-Through Requirements	Dynamic Real-Power Support	Volt-Var Function	Dynamic Reactive Current Support Function
Der Settings To Manage		Peak Power Limiting Function Load And Generation Following Function	Watt-Power Factor Function	Low/High Voltage Ride-Through Requirements
Multiple Grid Configurations (Including Islanding)				
Status Monitoring Points				
Event Logging And Reporting				
Time Adjustment Function		Battery Storage: Price-based Charge/ Discharge Function		
		Battery Storage: Direct Charge/Discharge Management Function		
		Battery Storage: Coordinated Charge/ Discharge Management Function		

*\*The function called "Price Or Temperature Driven Functions" is not specific to any of the fields above.*

**Figure 2-5**  
**Categorization of smart inverter functionality – purposes**

Understanding these different categorizations simplify the differences in the functions. A reader can look at the categorization to understand a function’s general purpose and what drives its

behavior. For most functions this is enough information to get a basic understanding of what the function does. For more in-depth knowledge on parameters or explanations on behavior the function should be referenced in the chapter of this report corresponding to this function.

# 3

## OVERVIEW OF THE 2016 UPDATE

The common functions for smart inverter functions report does not solely focus on solar. It also captures functionality for energy storage systems as both solar and energy storage are rooted to the grid through inverters. Smart inverter functions are very similar if not identical between energy storage systems and photovoltaic systems. There are obvious differences (charge discharge for energy storage being one example) but because they are so similar standards have kept the two together. An example, the current (AN2013-001) DNP3 standard is called DNP3 Profile for Advanced Photovoltaic Generation and Storage. These functions are so similar that separating them would be bad for the industry because having slight differences in seemingly identical functions is likely to cause confusion as the stakeholders in both industries are similar and often overlapping.

The functions defined in the pre-2016 versions of this document considered energy storage but the group that created them were mostly focused on solar. Two groups are addressing this and are working in parallel. The first is EPRI's Energy Storage Integration Council (ESIC). ESIC is reviewing functionality and identifying gaps and area for improvement to maximize the capabilities of energy storage systems. This group is open to the public. The other is MESA. They are a trade organization for energy storage systems and they are creating a specification for Energy Storage systems.

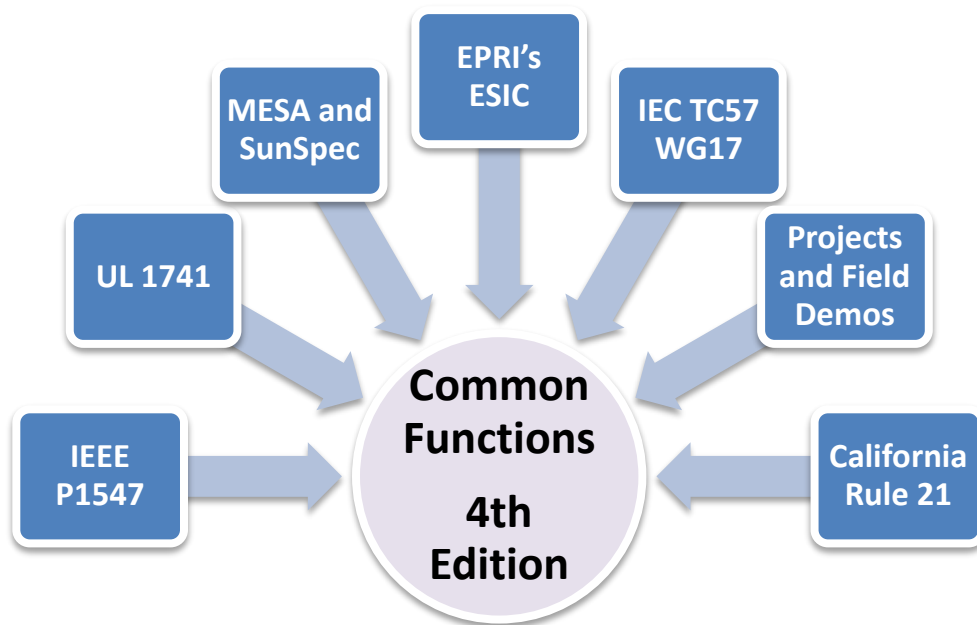

**Figure 3-1**  
The groups that helped influence the 2016 update to the Common Functions report.

There is a lot of work going on in this area. We are gathering information from changes in grid codes, discussions in standards groups, and other actions the industry has taken since the last group disbanded. This list of functions is never truly finished, we will always learn from field demonstrations and other industry activities and need to incorporate changes and additions to our list of smart functions.

The following list summarizes the changes made in 2016.

- Low/High Voltage Ride Through
  - The function was updated to reflect the anticipated revised IEEE Standard 1547 requirements and suggestions from the SunSpec Alliance.
- Low/High Frequency Ride Through
  - The function was updated to reflect the anticipated revised IEEE Standard 1547 requirements and suggestions from the SunSpec Alliance.
- Connect/Disconnect
  - Additional parameters were added to clarify where a physical operation of a switch or virtual disconnect was requested by the operator.
- Addition Types of Ramp Rates
  - Added additional ramp rates per guidance from the Smart Inverter Working Group (SIWG) and ESIC.
- Updated Support for Bi-Directional Power Flow
- Additional Curve – Watt-Var
  - Watt-Var is function being considered for addition in the anticipated revised IEEE Standard 1547 that was not previously included in this document.
- “State of Charge” Monitoring Points
  - The list of monitoring points was expanded to include state of charge parameters for energy storage system. The new parameters were provided by the Energy Storage Integration Council.
- General Terminology
  - Terminology was updated across the document. The most notable change was updating power flow (generating, charging, discharging) terminology to generic terms that represent both solar and storage technologies.

In addition to changes, there were some topics brought to the group that did not produce changes to the Common Functions to Smart Inverters. These topics are important for the industry so in 2016 a new section was added to the report called the Future Topics for Discussion. It can be found in Appendix A. This section is a reference for future revisions and serves to acknowledge the rapidly changing landscape for smart inverters.

# 4

## BASIC DEVICE SETTINGS AND LIMITS

### Scope of This Function

This proposal is for the Phase 1 Smart Inverter Communication Project, for the communications needed to establish basic device settings. Although this was not listed by the interest group as a “function” in its own right, it was recognized while working on the communications for the other functions that the ability to set basic device parameters (such as defaults) and other limits was needed.

This specification is intended to provide a flexible mechanism through which basic settings and device limits could be configured, if so desired. It is not intended to suggest that such settings are mandatory or to specifically define what values to set if used.

### Requirements/Use Cases

The context for the inclusion of these settings in this Phase 1 project includes a variety of needs that arose during the definition of the other functions. For example:

- **Reduced Operating Limits.** Certain DER may be limited to reduced operating levels at some point after production or deployment due to age or condition of equipment, or until certain repairs can be made. For example, an inverter may be reconfigured to reduce its maximum power level.
- **Increased Operating Limits.** The capabilities of certain DER may be increased at some point in its operating life, as a result of upgrades or expansions. New transistors or power circuitry, new cooling capabilities, or more sources (e.g. solar PV panels or battery cells) might be added.
- **Varying Operating Limits.** The capability of a DER unit might vary with certain regularity, as a function of season (temperature) or intended use.

### Prior Bodies of Work

The Smart Inverter Communication Initiative itself.

### Proposal

#### ***Basic Power Settings and Nameplate Values***

The settings described herein recognize that DER may have nameplate values that are fixed for the life of the product. These would theoretically be set by the manufacturer and would represent the as-built capabilities of the equipment. No mechanism to write to nameplate values is provided.

In addition to these nameplate values, basic settings are allowed that could be made writeable/configurable at some point after production to modify the original nameplate limits.

The settings listed in Table 4-1 are defined, as illustrated in Figure 4-1.

**Table 4-1**  
**Basic power and nameplate settings**

Name	Description
WMax	The maximum real power that the DER can deliver to the grid, in Watts
VAMax	The maximum apparent power that the DER can conduct, in Volt-Amperes
VARMax	The maximum reactive power that the DER can produce or absorb, in VARs
WChaMax	The maximum real power that the DER can absorb from the grid, in Watts (e.g. energy storage charging). Note that WChaMax may or may not differ from WMax.
VACHaMax	The maximum apparent power that the DER can absorb from the grid, in Volt-Amperes (e.g. energy storage charging). Note that VACHaMax may or may not differ from VAMax.
ARtg	A nameplate value, the maximum AC current level of the DER, in RMS Amps.

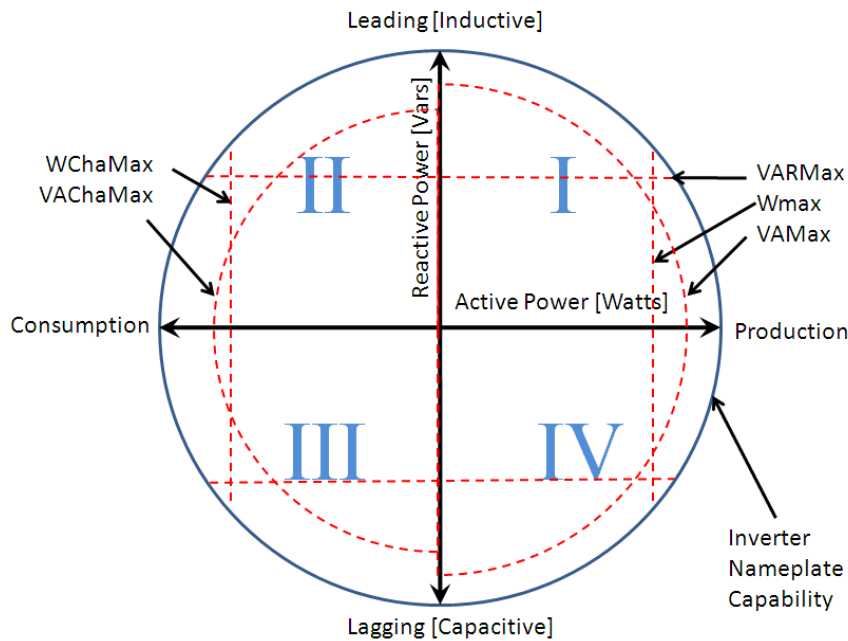

**Figure 4-1**  
**Basic power settings illustration**

Each of these parameters shall be supported by a function to read the present value, and to write a new value. In some cases, special or even onsite access might be required in order to modify these settings. Note that adjustments to these device ratings are NOT intended to be used regularly as an operational function, but only infrequently, when something physically changes in regards to the DER, its status, or its supporting infrastructure.

It is recognized that DER units may have limitations at any time regarding their ability to produce power or perform other functions. These limitations might stem from internal malfunctions, maintenance needs, or other special conditions. In this sense, all the functions

described in this document can be viewed as “requests” with the understanding that the DER will perform the function to the best of its ability, but with protecting itself as a first priority.

### Voltage Normalization Settings

For functions using voltage parameters (e.g. Volt-VAR modes, Volt-Watt modes, Dynamic Grid Support), a reference voltage and an offset voltage are defined as listed in Table 4-2 and illustrated in Figure 4-2.

All inverters behind one Point of Common Coupling (PCC) have a common reference voltage, but may differ in the voltage between their own Electrical Connection Point (ECP) and the PCC due to instrumentation errors or voltage shifts within a plant. These differences can be corrected by the parameter VRefOfs that is to be applied by each inverter. This correction voltage can be set once, or infrequently, and allows for homogenous controls and setting to be used for broadcasts to many DER.

**Table 4-2**  
Voltage normalization settings

Name	Description
VRef	The normal operating voltage for this DER site / service connection, in Volts.
VRefOfs	An offset voltage that represents an adjustment for this DER, relative to VRef, in Volts. VRefOfs is defined as the voltage at the ECP, relative to the PCC. For example, if the PCC VRef is 120V, and the nominal voltage at the DER’s ECP is 122V, then VRefOfs = +2V.

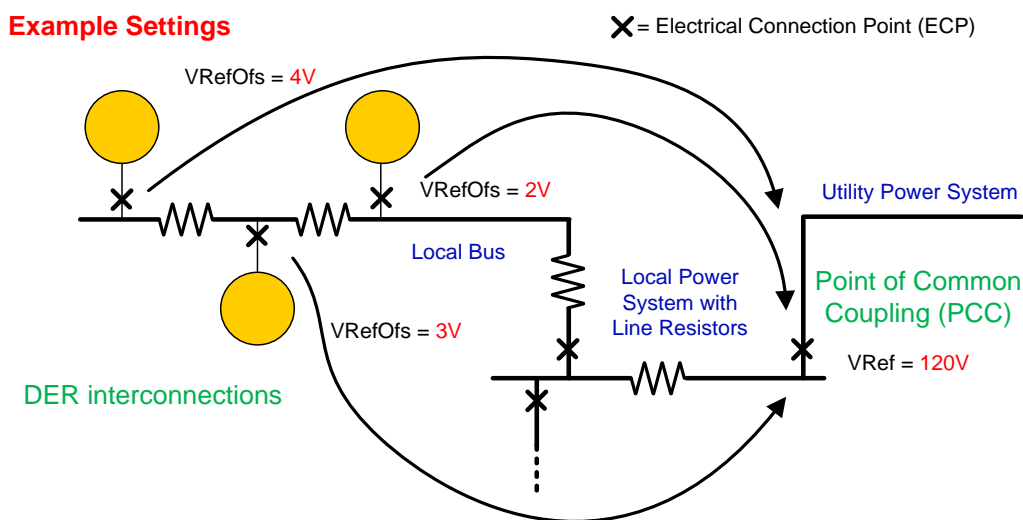

**Figure 4-2**  
Offset voltage illustration

As will be seen in the descriptions of functions that are based on local voltage as a control variable, settings are provided in terms of the effective percent voltage, which is defined as:

$$Effective\ Percent\ Voltage = 100 * (local\ measured\ voltage - V_{RefOfs}) / (V_{Ref})$$

## Real Power Ramp Rate Settings

The default ramp rate<sup>2</sup> of change of active power is provided by the parameter WGra. This parameter limits the rate of change of real power delivered or received due to either a change by a command or by an internal action such as a schedule change. This ramp rate (gradient) does not replace the specific ramp rates that may be directly set by the commands or schedules, but acts as the default if no specific ramp rate is specified with a command. WGra is defined as a percentage of WMax per second.

**Table 4-3**  
**Real power ramp rate<sup>2</sup> setting**

Name	Description
WGra	The default ramp rate of real power output in response to control changes. WGra is <sup>2</sup> defined as a percentage of WMax per second. This is used as default unless the other optional ramp rates including the ramp rates below or other function-specific ramp rates are used.
Increase Ramp Rate for Output	The default ramp rate of real power output in response to control changes. This parameter only applies to increases in power flow to the grid. This includes generation from solar systems or discharging from energy storage systems. (Optional)
Decrease Ramp Rate for Output	The default ramp rate of real power output in response to control changes. This parameter only applies to decreases in power flow to the grid. This includes generation from solar systems or discharging from energy storage systems. (Optional)
Increase Ramp Rate for Input	The default ramp rate of real power output in response to control changes. This parameter only applies to increases in power flow from the grid. This does not apply to solar but includes discharging for energy storage systems. (Optional)
Decrease Ramp Rate for Input	The default ramp rate of real power output in response to control changes. This parameter only applies to decreases in power flow from the grid. This does not apply to solar but includes discharging for energy storage systems. (Optional)

---

<sup>2</sup> Both ramp rates and ramp times are used throughout this report. The industry has not decided on which is most appropriate so this report covers ramp parameters as they were published in the 3rd Edition. Both ramp rates and ramp times are appropriate if applied correctly. Ramp times are represented in seconds until the full effect takes place where ramp rates are the number of units (Watts, VARs, PF) per second. A single approach is best for interoperability so if the industry moves towards one or the other this report will be updated to reflect their choice.

# 5

## CONNECT/DISCONNECT FUNCTION

### Scope of This Function

This specification is intended to provide a flexible mechanism through which a general Connect/Disconnect function could be configured, if so desired, and provide guidance on differentiating between operating a switch to achieve galvanic isolation and setting max power to zero or ceasing to energize. It is not intended to suggest that such a function is necessary or to specifically define what values to set or how it should be configured if used.

### Requirements/Use cases

The context for the inclusion of this function in this Phase 1 project includes a variety of needs that were expressed by utilities during the face-to-face workshop held in Albuquerque in 2009. For example:

- **Emergency Reduction in Distributed Generation.** Under certain circumstances, system voltage may rise to unacceptably high levels or certain grid assets (e.g. wires, transformers) may become overloaded. In these cases, it might become desirable or even necessary to disconnect distributed devices from the grid.
- **Malfunctioning DER Equipment.** Distributed generation or storage devices may be found to be malfunctioning – disrupting the grid due to some form of failure. In these cases, it might be desirable to disconnect the device from the power system.
- **Grid Maintenance or Repair.** Utilities may wish to disconnect DER devices from the grid during certain repairs or maintenance.

### Prior Bodies of Work

None referenced.

### Proposal

This function provides two options for an inverter to cease operation and disconnect from the grid. The first is to set the power output to zero. This is also known as cease to energize or as will be referred to in this document, a virtual disconnect. The second is the physical operation of a switch to galvanically isolate the inverter from the grid. This will be referred to as a physical disconnect in this document.

This function is not related to intentional islanding nor separating a customer from the grid. It refers to the management of a switch, or virtual switch, that separates at the DER from the grid while leaving customers connected to the grid. In reference to the example diagram in Figure 5-1, this function relates to the operation of the “Local DER Switch,” not the “Grid Switch.”

This function is assumed to be subordinate to any local safety switch operations, including a lock-out/tag-out system. In other words, a remote switch-connect request (or the timeout of a

switch disconnect request) would NOT result in reconnection of a system that was disconnected by some other means.

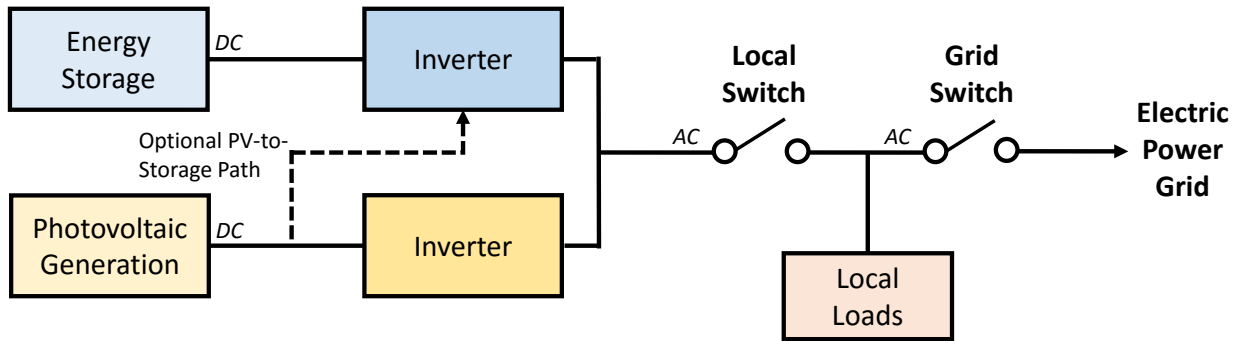

**Figure 5-1**  
**Example DER diagram**

It is proposed that this function be facilitated by two simple “Connect” or “Disconnect” commands – one for virtual and one for physical. A physical disconnect provides galvanic isolation between the inverter the grid. A virtual disconnect sets the output for both active and reactive power to zero. Both can be controlled individually. Inverters may support both, one, or neither of these.

A table below further explains this relationship.

**Table 5-1**  
**Precedence of commands on inverters that support both virtual and physical disconnects**

State of the Virtual Disconnect Parameter	State of the Physical Disconnect Parameter	Action from DER
<b>Connect</b>	Connect	Connect to the grid and energize.
<b>Connect</b>	Disconnect	Perform a physical disconnect but may remain energized and provide active and reactive power to devices on the same side of the disconnect switch as the inverter such as in an islanding scenario.
<b>Disconnect</b>	Connect	Perform a virtual disconnect but may remain galvanically connected to the grid.
<b>Disconnect</b>	Disconnect	Set both active and reactive power to zero but also operate disconnect switch to provide galvanic isolation.

The following information exchanges will support this function:

**Time Window:** a time, over which the switch operation is randomized. For example, if the “Time Window” is set to 60 seconds, then the switch operation occurs at a random time between 0 and 60 seconds. This setting is provided to accommodate communication systems that might address large numbers of devices in groups.

**Reversion Timeout:** a time, after which a command to disconnect expires and the device reconnects. Reversion Timeout = 0 means that there are no timeouts.

**Set Disconnect State:** a Boolean command, or pair of commands (a state and enable/disable command, depends on the particular protocol mapping) which instructs the physical DER switch to either open or close. The disconnect type defines what type of disconnect is being activated/deactivated.

**Set Disconnect Type:** a user selection of either actual or virtual disconnect.

**Read Switch State:** a query to read the present switch state (opened or closed) from the DER for the selected disconnect type.

**Set Virtual Disconnect Ramp Rate – Increasing Output:** The ramp rate of real power output when the inverter transitions from disconnect to producing power. The ramp rate is defined as a percentage of WMax per second. If parameter is not used the default ramp rates from “Real Power Ramp Rate Settings” will be applied. (Optional)

**Set Virtual Disconnect Ramp Rate – Decreasing Output:** The ramp rate of real power output when the inverter transitions from producing power to disconnected. The ramp rate is defined as a percentage of WMax per second. If parameter is not used the default ramp rates from “Real Power Ramp Rate Settings” will be applied. (Optional)

**Set Virtual Disconnect Ramp Rate – Increasing Input:** The ramp rate of real power output when the inverter transitions from disconnect to absorbing power. The ramp rate is defined as a percentage of WMax per second. If parameter is not used the default ramp rates from “Real Power Ramp Rate Settings” will be applied. Only applies to energy storage systems. (Optional)

**Set Virtual Disconnect Ramp Rate – Decreasing Input:** The ramp rate of real power output when the inverter transitions from absorbing power to disconnected. The ramp rate is defined as a percentage of WMax per second. If parameter is not used the default ramp rates from “Real Power Ramp Rate Settings” will be applied. Only applies to energy storage systems. (Optional)

## Editor Notes

The change in version four includes the addition of language to define the difference between two forms of connect/disconnect; power output set to zero and physical operation of the switch. This was discussed in multiple venues including ESIC’s Communications and Controls subgroup, MESA’s technical working group, the Rule 21 Smart Inverter Working Group and others. In this document it was agreed that the differentiation should be made to acknowledge that the two forms of connect/disconnect are not equal and should be distinguished from one another. However, it does not distinguish when one or the other should be applied. This should be determined by grid codes and the various use cases for inverters.

The group discussed the addition of language to capture virtual disconnect of both charging and discharging however it was decided this differentiation was not needed at this time.



# 6

## LIMIT DER POWER OUTPUT FUNCTION

### Scope of This Function

This specification is intended to provide a flexible mechanism through which the power either in or out of a distributed energy resource might be self-limited, if so desired. This includes generations from a photovoltaic system or the charging and discharging of an energy storage system. It is not intended to suggest that such a function is necessary or to specifically define what values to set or how it should be configured if used.

### Requirements/Use Cases

The context for the inclusion of this function in this Phase 1 project includes a variety of needs that were expressed by utilities during the face-to-face workshop held in Albuquerque in 2009. For example:

- **Localized (Customer Side of the Distribution Transformer) Overvoltage Conditions.** This function could be used to reduce distributed generation output to prevent localized overvoltage conditions.
- **Localized Asset Stress.** This function could be used to limit the maximum output from distributed generation to prevent the overloading of local assets such as transformers.
- **Feeder Overvoltage Conditions.** This function could be used across a large number of devices to prevent high-penetration DG from driving distribution system voltages too high during periods of light load.

### Prior Bodies of Work

None referenced.

### Proposal

#### *Device Ratings*

This function operates as a control, to establish an upper limit on the real power that the device can produce or discharge (deliver to the grid) and charge (consume from the grid) at its electrical connection point (ECP). The description herein references the basic device settings set forth in the Device Limits section of this document.

#### *Maximum Generation Level Function*

It is proposed that the Limit DER Power Output Function be percentage based, according to the “WMax” and “WChaMax” capability of the device. The effect of this setting is illustrated in Figure 6-1.

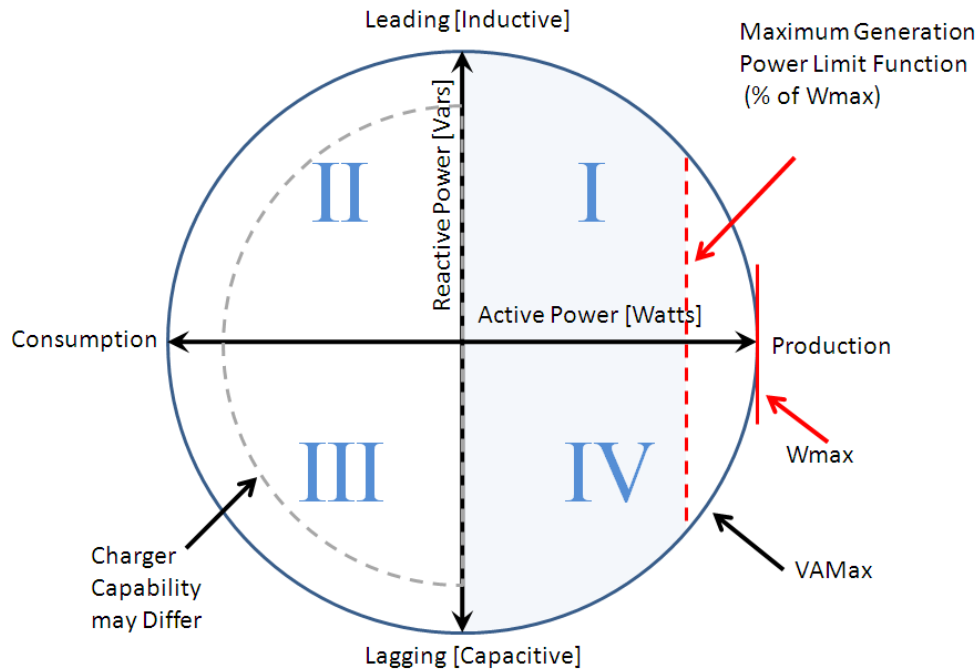

**Figure 6-1**  
**Example maximum generation settings**

The following information exchanges are associated with this function:

**Time Window:** a time in seconds, over which a new setting is to take effect. For example, if the “Time Window” is set to 60 seconds, then the DER would delay a random time between 0 and 60 seconds prior to beginning to make the new setting effect. This setting is provided to accommodate communication systems that might address large numbers of devices in groups.

**Reversion Timeout:** a time in seconds, after which a setting below 100% expires and the device returns to its natural “WMax, delivered” limits. Reversion Timeout = 0 means that there is no timeout.

**Ramp Time – Output Increasing:** a time in seconds, over which the DER linearly places the new limit into effect when increasing output. For example, if a device is operating with no limit on Watts generated (i.e. 100% setting), then receives a command to reduce to 80% with a “Ramp Time” of 60 seconds, then the upper limit on allowed Watts generated is reduced linearly from 100% to 80% over a 60 second period after the command begins to take effect. (See illustration in Figure 6-2). (Optional)

**Ramp Time – Output Decreasing:** a time in seconds, over which the DER linearly places the new limit into effect. For example, if a device is operating with no limit on Watts generated (i.e. 100% setting), then receives a command to reduce to 80% with a “Ramp Time” of 60 seconds, then the upper limit on allowed Watts generated is reduced linearly from 100% to 80% over a 60 second period after the command begins to take effect. (See illustration in Figure 6-2). (Optional)

**Ramp Time – Input Increasing:** a time in seconds, over which the DER linearly places the new limit into effect when decreasing input. Only applies to energy storage. (Optional)

**Ramp Time – Input Decreasing:** a time in seconds, over which the DER linearly places the new limit into effect when decreasing output. Only applies to energy storage. (Optional)

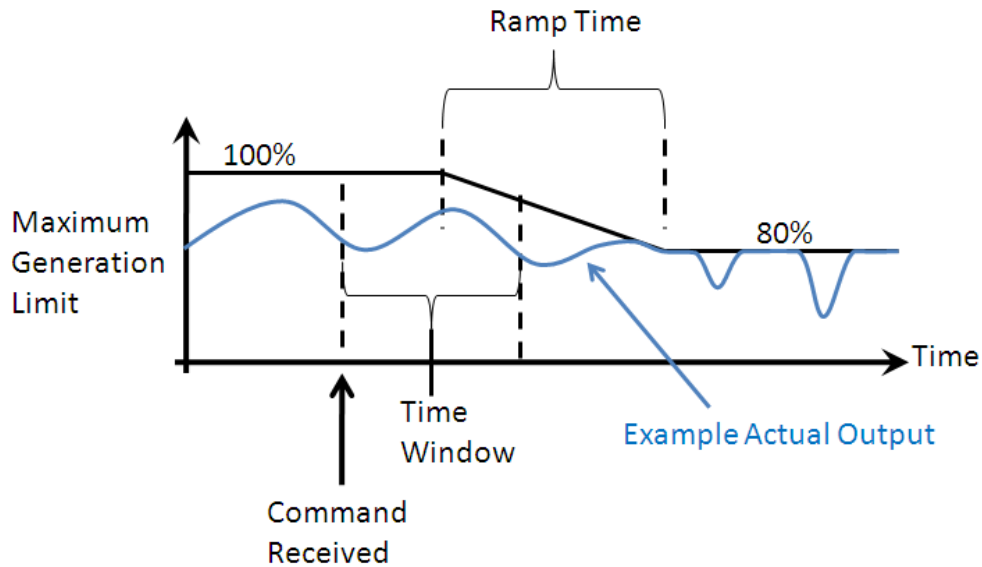

**Figure 6-2**  
Example function settings

**Read Maximum Output Power Setting:** a query to read the present setting as a percent of WMax\_Output.

**Set Maximum Output Power:** a command to set the maximum generation level as a percent of WMax\_Output. Percentage based settings allow communication to large groups of devices of differing sizes and capacities.

**Read Maximum Input Power Setting:** a query to read the present setting as a percent of WMax\_Input.

**Set Maximum Input Power:** a command to set the maximum generation level as a percent of WMax\_Input. Percentage based settings allow communication to large groups of devices of differing sizes and capacities.



# 7

## ENERGY STORAGE: DIRECT CHARGE/DISCHARGE MANAGEMENT FUNCTION

### Scope of This Function

This function is intended to provide a simple mechanism through which the charging and discharging of energy storage systems may be directly managed. A price-based (or relative energy value) function which assumes that the storage unit manages its own actions is defined separately. This present charge/discharge function, however, assumes that the intelligence which determines charging or discharging resides outside the storage system, and that the storage system (to the extent possible) follows the requests it is given.

It is not intended to suggest that such a function is necessary or to specifically define what values to set or how it should be configured if used.

### Requirements/Use Cases

The context for the inclusion of this function in this Phase 1 project was based on a strong representation by inverter manufacturers associated with storage systems in addition to PV systems. Both self-managed and externally-managed modes of operation were identified as needs by both utilities and device manufacturers during the face-to-face workshop held in Albuquerque in 2009.

### Prior Bodies of Work

None referenced.

### Proposal

#### ***General Storage System Settings***

The charge/discharge function described below is supported by these addition storage-related settings:

**Set Maximum Storage Charge Rate (WMaxStoCh):** The maximum power rate at which the storage unit may be charged, in Watts.

**Set Maximum Storage Discharge Rate (WMaxStoDis):** The maximum power rate at which the storage unit may be discharged, in Watts.

**Maximum Reserve Percentage (% of Usable Capacity):** A reserve percentage that the user may define if desired. The storage system will not charge above this amount until the reserve percentage is changed. Refer to Status Monitoring Points for more information on this parameter and other State of Charge related parameters.

**Minimum Reserve Percentage (% of Usable Capacity):** A reserve percentage that the user may define if desired. The storage system will not discharge below this amount until the reserve percentage is changed. Refer to Status Monitoring Points for more information on this parameter and other State of Charge related parameters.

### ***Direct Charge Discharge Request***

It is proposed that this function provide the storage system with a direct request to set the storage charge or discharge rate to a given value. The values will be provided as a percentage, in terms of the WMaxStoDis (for discharging) and WMaxStoCh (for charging) ratings of the storage unit. It is recognized that the maximum charging rate and the maximum discharging rate may differ, such that a setting of 50% charging might result in a different power magnitude than a setting of 50% discharging.

It is proposed that this function be supported by the following information exchanges:

**Randomization Time Window:** a time in seconds, over which the DER randomly delays prior to beginning to put a new charge or discharge rate setting into effect. The use of this setting is the same as with the Connect/Disconnect and other previously defined functions, although the value used for each may differ.

**Reversion Timeout:** a time in seconds, after which a DER will return to its default charge or discharge setting (typically an idle state). Reversion Timeout = 0 means that there is no timeout.

**Ramp Time:** a set of four times reported in seconds, over which the DER linearly places the new charge or discharge setting into effect. The use of this setting is the same as with the Limit DER Power Output Function previously defined, although the value used may differ. Similarly, to Limit DER Power Output Function four varieties exist including:

**Ramp Time – Output Increasing:** a time in seconds, over which the DER linearly places the new limit into effect when increasing output.

**Ramp Time – Output Decreasing:** a time in seconds, over which the DER linearly places the new limit into effect. (Optional)

**Ramp Time – Input Increasing:** a time in seconds, over which the DER linearly places the new limit into effect when decreasing input. Only applies to energy storage. (Optional)

**Ramp Time – Input Decreasing:** a time in seconds, over which the DER linearly places the new limit into effect when decreasing output. Only applies to energy storage. (Optional)

**Read Charge / Discharge Rate:** a query to read the present setting.

**Set Charge / Discharge Rate:** a request to set the charge/discharge rate. This setting is provided as a percentage between +100% (discharging) and -100% (charging). Numerical scaling will vary by protocol mapping. It is understood that this is a “request” and that the actual ability of the end device to charge or discharge will be affected by many factors, including present energy storage charge level, temperature, etc.

**Activate Direct Charge / Discharge Management Mode:** a Boolean that activates the direct charge/discharge mode (e.g. the storage system is following either direct charge/discharge requests or a schedule for the same) 1 = Direct C/D Mode is Active, 0 = Not active.

### ***Charge/Discharge Schedules***

In addition to direct (immediate) setting, a schedule may be used to manage the charging and discharging. These schedules will allow the “Charge/Discharge Rate” parameter defined in the direct function above to be scheduled relative to time. Schedules will allow for daily, weekly, or seasonal recurrence (looping).

This function will utilize the existing scheduling mechanisms that exist in most communication protocols, so no attempt will be made here to establish a new scheduling mechanism. At transition points in charge/discharge schedules, the “Ramp Time” and “Randomization Time Window” settings apply, in order to prevent abrupt transitions.



# 8

## **ENERGY STORAGE: PRICE-BASED CHARGE/ DISCHARGE FUNCTION**

### **Scope of This Function**

This function is intended to provide a simple mechanism through which energy storage systems may be informed of the price of energy so that they may manage charging and discharging accordingly. A direct charge/discharge function, which assumes that the storage unit is managed by a remote entity, is defined separately. This price-based function, however, assumes that the intelligence which determines charging or discharging resides within the storage system, and that the storage system manages its own affairs relative to this signal and other preferences that may be set by the storage system owner.

It is not intended to suggest that such a function is necessary or to specifically define what values to set or how it should be configured if used.

### **Requirements/Use Cases**

In addition to direct settings for charging and discharging storage, utilities and storage system providers indicated a requirement for a mode in which the storage system would manage its own charging and discharging. The idea for this function is that the storage system is provided with a signal indicative of the price (or value) of energy. The storage system then manages its own decisions about when to charge and discharge, and at what levels.

This kind of autonomous approach allows that the storage system might be taking into account a range of owner preferences and settings, such as considerations of life expectancy of the energy storage medium, anticipation of bad weather /outage, and predictions regarding real-time energy price swings. It enables energy storage system providers to develop innovative learning algorithms and predictive algorithms to optimize asset value for the owner rather than leaving these algorithms to another entity that may not understand the energy storage system's capabilities and limitations as well.

### **Prior Bodies of Work**

None referenced.

### **Proposal**

#### ***General Storage System Settings***

The price-based charge/discharge function will utilize the same general storage system settings identified in the direct charge/discharge function (i.e. only one set of these settings will exist in the unit). This includes Maximum Intermittency Ramp Rate, Maximum Storage Charge Rate, Maximum Storage Discharge Rate, Maximum Reserve Percentage, and Minimum Reserve Percentage.

### **Price-Based Charge Discharge Mode**

It is proposed that this function provide the storage system with energy price information. It is acknowledged that in some scenarios this price information could actually be an arbitrary “relative price indicator” or “energy value indicator”, according to the arrangement between the entity generating the signal and the storage system owner.

It is proposed that this function be supported by the following information exchanges:

**Set Price – Power Output:** a setting of the price (or abstract energy value) for when the energy storage system begins discharging. The scaling of this value will be determined by the particular communication protocol mapping.

**Set Price – Power Input:** a setting of the price (or abstract energy value) for when the energy storage system begins charging. The scaling of this value will be determined by the particular communication protocol mapping.

**Read Present Price:** a query to read the present price setting.

**Randomization Time Window:** a time in seconds, over which the DER randomly delays prior to beginning to put a new price setting into effect. The purpose of this setting is to allow multiple systems to be managed using a single broadcast or multicast message, while avoiding simultaneous responses from each device.

**Reversion Timeout:** a time in seconds, after which a new price signal is no longer valid. A DER will return to its default behavior (typically an idle state). Reversion Timeout = 0 means that there is no timeout.

**Ramp Times:** a set of four times reported in seconds, over which the DER linearly varies its charge or discharge levels in response to a price change. The purpose of this setting is to avoid sudden or abrupt changes in energy input/output at step changes in price. Similarly, to Limit DER Power Output Function four varieties exist including:

- **Ramp Time – Output Increasing:** a time in seconds, over which the DER linearly places the new limit into effect when increasing output.
- **Ramp Time – Output Decreasing:** a time in seconds, over which the DER linearly places the new limit into effect. (Optional)
- **Ramp Time – Input Increasing:** a time in seconds, over which the DER linearly places the new limit into effect when decreasing input. Only applies to energy storage. (Optional)
- **Ramp Time – Input Decreasing:** a time in seconds, over which the DER linearly places the new limit into effect when decreasing output. Only applies to energy storage. (Optional)

**Activate Price-Based Charge/Discharge Management Mode:** a Boolean that activates the price-based charge/discharge mode (e.g. the storage system is managing based on the price signal, possibly incorporating its history, and forward-looking schedules, if provided). 1 = Price-Based C/D Mode is Active, 0 = Not active.

## ***Price Schedules***

In addition to an immediate price setting (i.e. the price now), a schedule will ideally be used to provide storage systems with a forward-looking view of price. The use of schedules would allow the “Price” parameter defined in the setting above to be scheduled relative to time. Schedules will allow for daily, weekly, or seasonal recurrence (looping).

For some products, price-based management might not be possible without a forward-looking schedule. These might support a fixed rate structure such as Time-Of-Use, but not Real Time Pricing. Other products could include adaptive/learning algorithms that monitor the history of the price information they have received and manage based on that history.

This function will utilize the existing scheduling mechanisms that exist in most communication protocols, so no attempt will be made here to establish a new scheduling mechanism. At transition points in price schedules, the “Ramp Time” and “Randomization Time Window” settings apply, in order to prevent abrupt transitions.



# 9

## **ENERGY STORAGE: COORDINATED CHARGE/ DISCHARGE MANAGEMENT FUNCTION**

### **Scope of This Function**

This function identifies a set of quantities that can be read from energy storage systems to enable their management to be coordinated with the local needs of the storage users in terms of target charge level and schedule. This function enables the separately-described direct charge/discharge function to be handled more intelligently, ensuring that the storage system achieves a target state of charge by a specified time.

The information items identified herein can be read from the storage system to identify the constraints associated with a dynamic charging solution. This function does not describe the optimization algorithms that could be used by a controlling entity to plan power flow to meet grid requirements and also ensure completion of charging of the storage system.

It is not intended to suggest that such a function is necessary or to specifically define what values to set or how it should be configured if used.

### **Requirements/Use Cases**

The separately defined “direct charge/discharge” function only allows a controlling entity to directly manage the power flow of a storage system as bounded by being fully charged or discharged to a minimum reserve level. In such a case, it is assumed by the controlling entity that it is acceptable to terminate a session with the storage system depleted to its minimum reserve level and that any recharging will be a self-directed activity conducted by the storage system after it is released.

This could be a problem if the storage system must achieve a target state of charge by a specified time and there is not enough time to complete unrestricted charging from the minimum reserve level beginning at the time of release by the controlling entity. The storage system could either be left with insufficient charge to perform needed tasks or it might abruptly disengage early from the controlling entity and revert to charging to meet its own requirements. This coordinated charge/discharge management is intended to help avoid such circumstances.

This function may be useful with an electric vehicle that needs to be fully charged by a specified departure time but is capable of serving as a distributed energy resource in the interim. This function could also be useful with a Community Energy Storage (CES) unit that may need to be fully charged by the time that a severe storm is forecast to arrive in the service area.

### **Prior Bodies of Work**

The SAE developed the basic principles for this function for use with electric vehicles that are capable of discharging power to the grid. This work is described in SAE J2836/3<sup>TM</sup> Use Cases for Plug-in Vehicle Communication as a Distributed Energy Resource.

## Proposal

### ***Parameters from the Direct Charge/Discharge Function***

This coordinated charge/discharge function builds on the direct charge/discharge function. The command structure is unchanged from that of the direct charge/discharge function. The following parameters described in the Charge/Discharge function are also used in relation to this function and full definitions will not be repeated here:

- Maximum Reserve Percentage
- Minimum Reserve Percentage Set Maximum Storage Charge Rate (WMaxStoCh)
- Set Maximum Storage Discharge Rate (WMaxStoDis)
- Randomization Time Window
- Reversion Timeout
- Ramp Time – Output Increasing
- Ramp Time – Output Decreasing
- Ramp Time – Input Increasing
- Ramp Time – Input Decreasing
- Read Charge/Discharge Rate
- Set Charge/Discharge Rate
- Activate Direct Charge/Discharge Management Mode

### ***Basic Charging Model***

The charging model for this function is based on the storage system being authorized by the controlling entity to engage in unrestricted charging at up to 100% of its maximum charging rate (WMaxStoCh). The model is shown in Figure 9-1, and parameters are defined below. Not all of the parameters are shown in the figure. The figure shows a representative charging profile of power versus time. The area under the curve, shown in green, is the total energy remaining to be transferred to the system from the grid at a specific time of reference. It is not just the energy stored in the system and it includes losses.

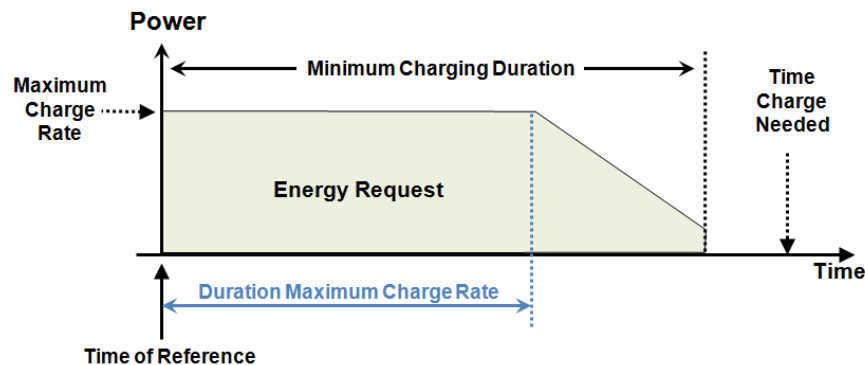
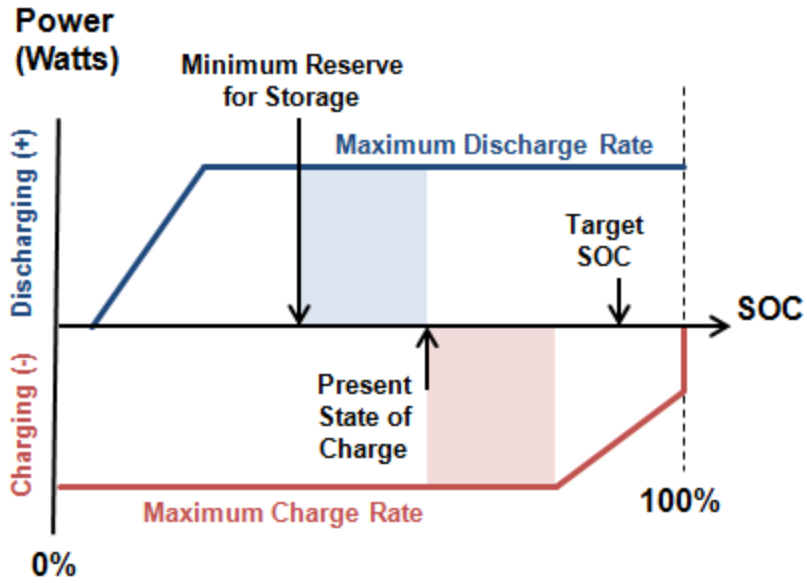

**Figure 9-1**  
**Storage system model: time-base**

**Duration at Maximum Charging and Discharging Rates**

To support this function, the reference charging and discharging power limit curves for a storage system are set forth, as illustrated in Figure 9-2. The discharging power limit is shown in blue on top and the charging power limit is shown in red on the bottom. The defined maximums represent levels that can be sustained across a broad range of SOC. The example profile shown identifies a certain SOC below which the DER can no longer sustain discharging at the Maximum Discharge Rate, and the discharge rate slows. Likewise, it identifies a certain SOC, above which the DER can no longer sustain charging at the Maximum Charge Rate. Such limitations are possible in practice, and while not passed across the communication interface, would be known to the storage system and reflected in the duration parameters that it reports.

These parameters are typically known to the DER by design, but may not be known by other entities that manage the DER. The shaded blue area in Figure 9-2 represents the present energy in the storage system that is available for production at the Maximum Discharge Rate. Likewise, the shaded red area represents the capacity of the DER to store additional energy at the Maximum Charge Rate. As illustrated, this reference profile recognizes that more energy might be available for either charge or discharge, but not at the maximum charge/discharge rates.



**Figure 9-2**  
**Storage system model: SOC-base**

This function results in the following parameters which may be read-from, and in some cases written-to, a storage DER. In the event that coordinated charge/discharge management is needed (e.g. there is a local need for a certain target charge at a certain time) these parameters are relevant.

**Table 9-1  
Parameters for coordinated energy storage management**

Name	Description
Target State of Charge (read or write)	<p>This parameter represents the target state of charge that the system is expected to achieve, as a percentage of the usable capacity.</p> <p>This quantity may be:</p> <ul style="list-style-type: none"> <li>• Read-from the DER, as in cases where the target state of charge is determined locally, such as when an electric vehicle is set locally to require a certain charge by a certain time.</li> <li>• Written-to the DER, as in cases where the target state of charge is determined by a remote managing entity, such as when a utility is informing community energy storage systems to be prepared with a certain storage level by the time that a storm is expected in the area.</li> </ul>
Time Charge Needed (read or write)	<p>This parameter represents the time by which the storage system must reach the target SOC. This quantity may be read-from, or written-to the DER as described in the examples given in the “Target State of Charge” parameter description.</p> <p>Setting the value to that of a distant date would prevent any conflict which could cause the DER to disengage and revert to charging at the Maximum Charge Rate.</p>
Energy Request (read only)	<p>This parameter represents the amount of energy (Watt-hours) that must be transferred from the grid to the charger to move the SOC from the value at the specific time of reference to the target SOC. This quantity is calculated by the DER and must be updated as the SOC changes during charging or discharging. As possible, the calculation shall account for changes in usable capacity based on temperature, cell equalization, age, and other factors, charger efficiency, and parasitic loads (such as cooling systems).</p>
Minimum Charging Duration (read only)	<p>This parameter represents the minimum duration (seconds) to move from the SOC at the time of reference to the target SOC. This assumes that the DER is able to charge at 100% of the Maximum Charge Rate (WMaxStoCh). This parameter is calculated by the DER and must be updated as the SOC changes during charging or discharging. The calculation shall take into account all charging profile characteristics, such as a decrease in charging rate as 100% SOC is reached as illustrated in Figure 9-1.</p>
Time of Reference (read only)	<p>This parameter identifies the time that the SOC is measured or computed by the storage system and is the basis for the Energy Request, Minimum Charging Duration, and other parameters, as illustrated in Figure 9-1. This parameter may be useful to a controlling entity to correct for any delays between measurement of SOC by the storage system and use of the calculated parameters by the controlling entity to aid in managing the charging and discharging of the DER.</p>

Name	Description
Duration at Maximum Charge Rate (read only)	<p>This parameter identifies the duration that energy can be stored at the <b>Maximum Charge Rate</b>. This duration is calculated by the storage system based on the available capacity to absorb energy to the SOC above which the maximum charging rate can no longer be sustained. This calculation shall account for losses.</p> <p>In the event that “<b>Time Charge Needed</b>” is reached before reaching the SOC limit for <b>Maximum Charge Rate</b>, then this duration parameter is determined by the “<b>Time Charge Needed</b>”. In effect, the energy that can be stored from the grid is the product of the <b>Duration at Maximum Charge Rate</b> and the <b>Maximum Charge Rate</b>.</p>
Duration Maximum Discharge Rate (read only)	<p>This parameter identifies the duration that energy can be delivered at the <b>Maximum Discharge Rate</b>. This duration is calculated by the storage system based on the available capacity to discharge to the “Minimum Reserve Percentage” or the SOC below which the maximum discharging rate can no longer be sustained (whichever is greater). This calculation shall account for losses.</p> <p>In effect, the energy that can be delivered to the grid is the product of the <b>Duration at Maximum Discharge Rate</b> and the <b>Maximum Discharge Rate</b>.</p> <p>This discharge duration may be further limited by a target-charge requirement, if there is not sufficient time to discharge for this duration and then successfully recharge to the target SOC by Time Charge Needed. This scenario is illustrated in Figure 9-3.</p> <p>The storage system uses Energy Request, Minimum Charging Duration, and Time Charge Needed as part of the computation of this parameter.</p>

The **Duration at Maximum Charge Rate** and the **Duration at Maximum Discharge Rate** are key parameters that the controlling entity can use to plan storage DER management. The charging model constraints are embedded in the calculation of these two parameters. At any time of reference these parameters can be recalculated and read by a controlling entity. In this way, the controlling entity may know from the **Duration at Maximum Discharge Rate** how much energy is available to the grid from the storage system at the **Maximum Discharge Rate**.

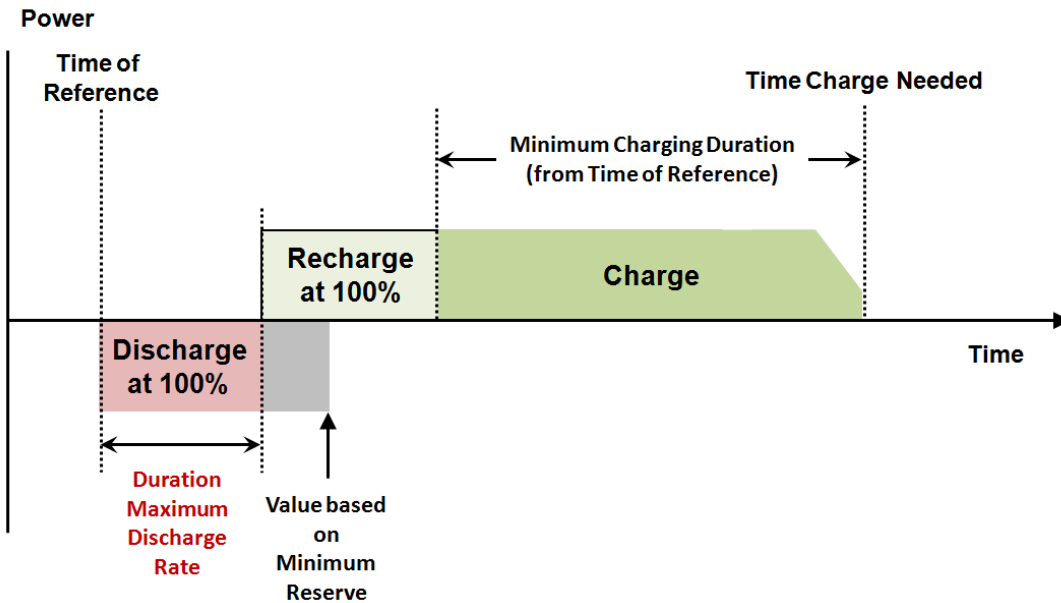

**Figure 9-3**  
**Example of using the duration at maximum discharge rate**

The **Target State of Charge** and **Time Charge Needed** parameters could result in a DER overriding other settings or modes affecting charging and discharging. This is true regardless of whether these parameters are set remotely or determined locally. This depends on the design and purpose of the DER, as to how it prioritizes achieving the target SOC at the specified time over following a power set-point. This DER default behavior may be selectable as part of an enrollment process for a specific application.

For example, an electric vehicle may prioritize its need to achieve a target SOC by its scheduled departure time. If a utility requests a fixed Charge Rate that would result in the vehicle being fully charged at 11:00 but the owner of the vehicle locally requested a full charge by 8:00, the electric vehicle would revert to charging at its maximum rate at the latest time needed to achieve that objective. The utility would know this could happen when remaining duration until the Time Charge Needed approaches the Minimum Charging Duration – so there would be no surprise.

This could also occur if the storage asset is completely managed remotely by the utility; for instance, if the utility programmed a schedule in the inverter to discharge at a fixed rate for four hours, but during the second hour an operator changed the Target State of Charge such that it would require a reversion to charging at max charging rate after one more hour of discharging, the inverter would switch to charging at maximum rate in one hour.

As shown in these examples, a reversion by a storage DER to charging at maximum rate could occur if there becomes a conflict between continuing operation at the current power setpoint and the ability to achieve the Target SOC in the time remaining until the Time Charge Needed. However, the reversion behavior can be defeated by setting the Time Charge Needed to a distant time (e.g. one year out, exact method to be defined by the protocol mapping), or whatever which eliminates any conflict.

# 10

## FIXED POWER FACTOR FUNCTION

### Scope of This Function

This function is intended to provide a simple mechanism through which the power factor of an inverter can be changed.

### Scope of This Function

This function is intended to provide a simple mechanism through which the power factor of a DER may be set to a fixed value. It is not intended to suggest that such a function is necessary or to specifically define what values to set or how it should be configured if used.

### Requirements/Use Cases

The context for the inclusion of this function in this Phase 1 project was based on legacy capabilities of distributed generators. Although more intelligent Volt-VAR functionality is preferred looking forward, inclusion of this function was viewed as a necessity for the present. This need was expressed by both utilities and device manufacturers during the face-to-face workshop held in Albuquerque in 2009.

### Prior Bodies of Work

None referenced.

### Proposal

#### *Defining the Power Factor Value*

In IEC 61850, power factor is a signed value between -1.00 and +1.00. Both -1.00 and +1.00 produce the same result, no VARs. A PF setting of Zero is not allowed. In IEC 61850, the meaning of the sign of the value varies depending on the sign convention used, as shown in Figure 10-1:

- IEC, in which supplying or generating active power is positive and demanding active power is negative
- IEEE, in which a leading (capacitive) power factor is positive and a lagging (inductive) power factor is negative

IEC 61850 provides a parameter, DRCC.OutPFSign, which normally permits changing the sign convention between IEC and IEEE. This function will likewise support this flexibility as described below.

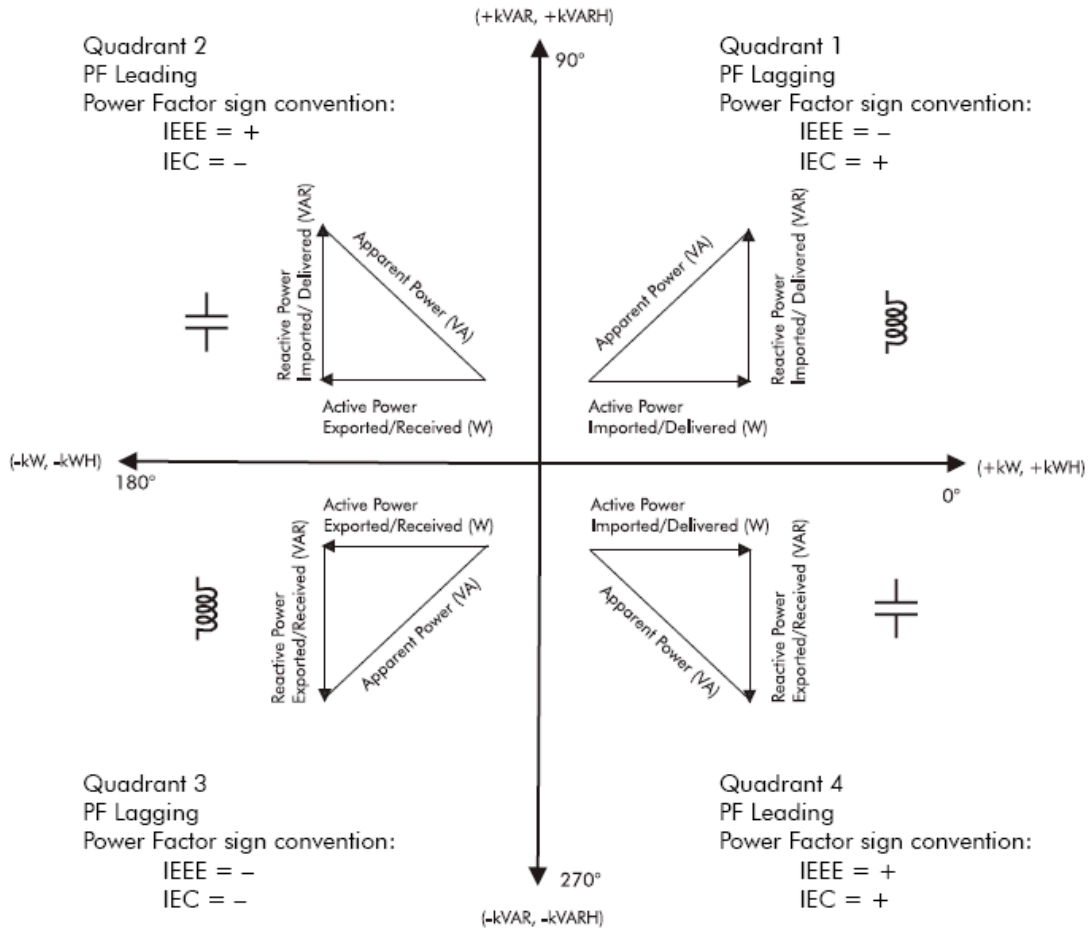

**Figure 10-1**  
**IEC and IEEE power factor sign conventions**

**Power Factor Setting Function**

It is proposed that this function be facilitated by a simple but flexible power factor setting, supported by the following information exchanges:

**Set Power Factor – Positive Current, Power Flow to Grid:** a command to set the power factor. Typically provided as a number between +1.00 and -1.00, each of which results in zero VARs. A setting of zero may not be used. Numerical scaling will vary by protocol mapping.

**Set Power Factor – Negative Current, Charging:** a command to set the power factor. Typically provided as a number between +1.00 and -1.00, each of which results in zero VARs. A setting of zero may not be used. Numerical scaling will vary by protocol mapping. Only applies to energy storage systems. **Power Factor Type:** An enumeration to identify how the power factor setting is to be interpreted. (See Figure 10-1)

- 1 = IEC Convention
- 2 = IEEE Convention

**Time Window:** a time in seconds, over which the DER randomly delays prior to beginning to put a new power factor setting into effect. The use of this setting is the same as with the Connect/Disconnect and other previously defined functions, although the value used for each may differ.

**Reversion Timeout:** a time in seconds, after which a DER will return to its default PF setting. Reversion Timeout = 0 means that there is no timeout.

**Ramp Time:** a set of four times reported in seconds, over which the DER linearly places the new PF setting into effect. The use of this setting is the same as with the Limit DER Power Output Function previously defined, although the value used may differ. Similarly, to Limit DER Power Output Function four varieties exist including:

- **Ramp Time – Output Increasing:** a time in seconds, over which the DER linearly places the new PF limit into effect when increasing output.
  - **Ramp Time – Output Decreasing:** a time in seconds, over which the DER linearly places the new PF limit into effect. (Optional)
  - **Ramp Time – Input Increasing:** a time in seconds, over which the DER linearly places the new PF limit into effect when decreasing input. Only applies to energy storage. (Optional)
  - **Ramp Time – Input Decreasing:** a time in seconds, over which the DER linearly places the new PF limit into effect when decreasing output. Only applies to energy storage. (Optional)
- Read Power Factor Setting:** a query to read the present setting.



# 11

## VOLT-VAR FUNCTION

### Scope of This Function

This function is intended to provide a mechanism through which a DER may be configured to manage its own VAR output in response to the local service voltage. It is not intended to suggest that such a function is necessary or to specifically define what values to set or how it should be configured if used.

### Requirements/Use Cases

The context for the inclusion of this function in this Phase 1 project was based on priority set by the initiatives participants at the initial face-to-face workshop held in Albuquerque in 2009.

### Prior Bodies of Work

None referenced.

### Proposal

#### *Use of Configurable Volt-VAR Curves*

It is proposed that each desired Volt-VAR behavior be consider a “Volt-VAR mode” and that each be configured using a two-dimensional array of points as illustrated in Figure 11-1.

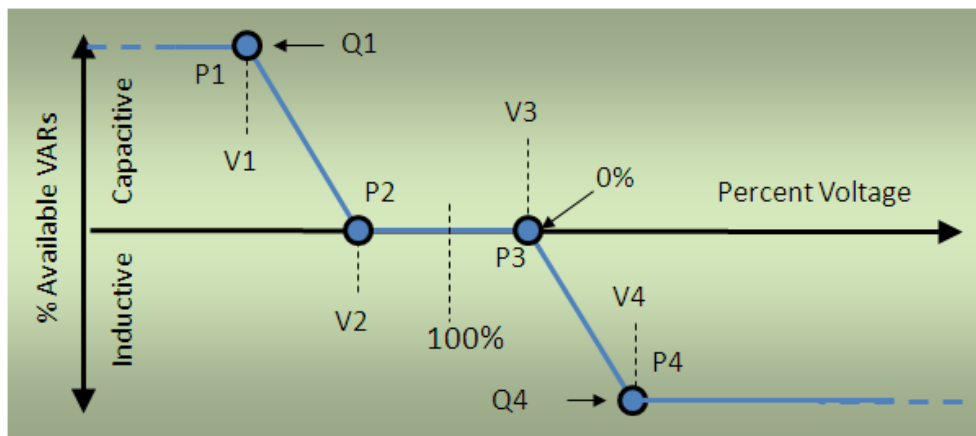

**Figure 11-1**  
**Example array settings to describe desired volt-VAR behavior**

Each array will have a variable number of points, which together define a piece-wise linear curve of the desired Volt-VAR behavior. In the example of Figure 11-1, there are 4 points, labeled P1 through P4. The configuration array will include for each point a voltage, given in % of VRef, and a desired VAR level, given in % of available VARs, see description below.

By definition, the desired VAR level is assumed to remain constant for voltages below P1 (e.g. at the Q1 level) and above the highest voltage point (P4 in this illustration), at Q4. As shown, the

first point in the Volt-VAR configuration is to be the lowest voltage point and the last the highest voltage, with the voltage increasing or holding the same for each successive point.

Configurations could have only one point (a horizontal line) two points (a ramp), or many points, limited only by the manufacturer's limitation or the specific protocol mapping.

Multiple y-axes are supported by this function.

### **Percent of Maximum Rated Apparent (VA) Power**

In the case where an inverter does not have a VAR rating the operator can use the rating on apparent power to determine 100% VARs. This is different than "Percent of Maximum Rated Reactive Power with VARs Precedence" because sometimes the manufacturers put limits on VARs that are smaller than VA. If Max VARs is equal to VA, then they are the same. See Figure 11-2.

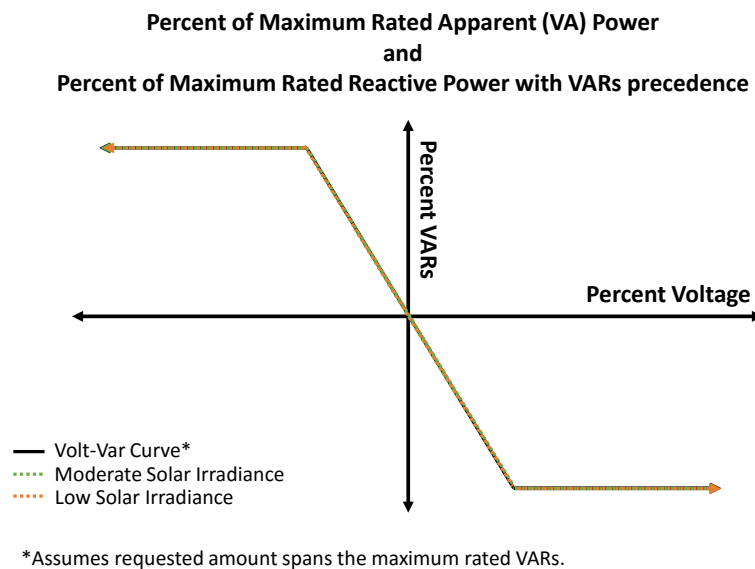

**Figure 11-2**  
**Example of both percent of maximum rated apparent (VA) power and percent of maximum rated reactive power with VARs precedence**

### **Percent of Maximum Rated Reactive Power with VARs Precedence**

In this mode the y-axis is percent of the rating for reactive power. VARs precedence means that the function will sacrifice watts to provide the requested VARs if the VA limit of the inverter is exceeded. See Figure 11-2.

### **Percent of Maximum Rated Reactive Power with Watts Precedence**

In this mode the y-axis is percent of the rating for reactive power. VARs precedence means that the function will not sacrifice watts to provide the requested VARs if the VA limit of the inverter is exceeded. The inverter scales the VAR output but continues to follow the curve when it can. See Figure 11-3.

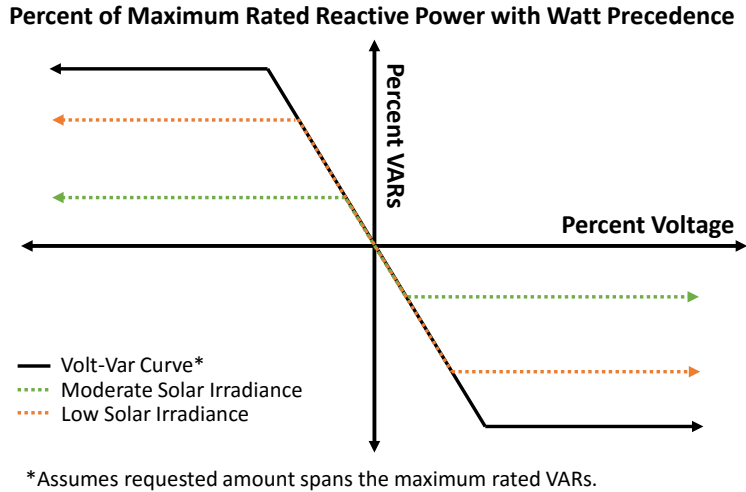

**Figure 11-3**  
**Example of percent of maximum rated reactive power, with watt precedence**

***Percent of Maximum Available Reactive Power, with Watts Precedence***

In this mode the y-axis is percent of the currently available reactive power. This differs from the others because it readjusts the entire curve to be in terms of percent of available reactive power given the VA rating of the inverter and the active power being delivered by the inverter. This causes the entire curve to change in relation to the new reference point. See Figure 11-4.

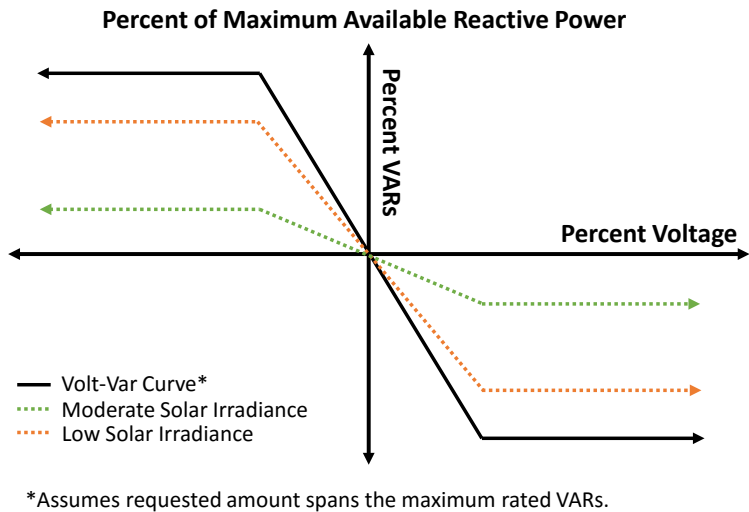

**Figure 11-4**  
**Example of percent of maximum available reactive power, with watt precedence**

***Supporting Curve Hysteresis***

In some cases, it may be desired to support and employ a hysteresis in the Volt-VAR settings. This is accommodated as illustrated in Figure 11-5, by extending the Volt-VAR configuration array with additional points that trace back toward the left after reaching the highest point.

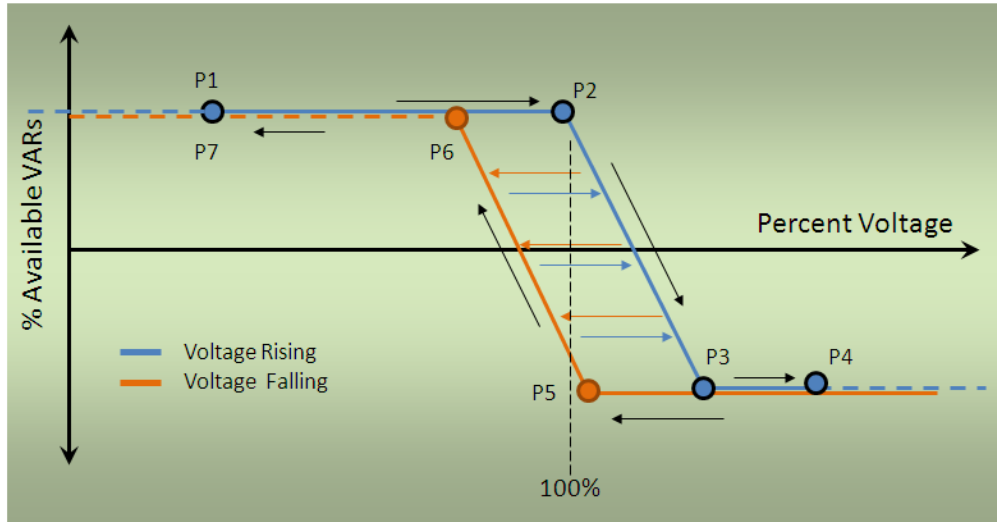

**Figure 11-5**  
**Example array settings with hysteresis**

In this example, the desired Volt-VAR behavior is illustrated without any dead-band (an area of zero-VARs as shown in the previous example) around 100%. Points P5 and P6 are added to the configuration array to create the hysteresis setting. One way to think of how these settings work is like a X-Y pen plotter. The pen goes down on the paper at the first point in the array, traces straight lines to each additional point, continuing to the last point to trace out the desired behavior. To be a valid configuration, the points in the array must begin at the lowest voltage %, then continue incrementally to the highest voltage % as described in the previous section, then (if hysteresis is being used) returning to the left, with the voltage % decreasing or holding the same with each successive point. In this way, there may only be one point in a configuration array at which the voltage reverses direction.

In a configuration with hysteresis, the last point in the array must have the same % Available VAR level as the first point (i.e. it traces out a complete loop). The highest voltage point in a configuration array with hysteresis may not be duplicated.

### ***Defining Valid Volt-VAR Configuration Arrays***

Different protocol mappings and/or different products may have different limitations regarding Volt-VAR curve configurations. This may include the maximum number of points, whether or not hysteresis is supported, maximum % VAR level, etc. It is the duty of purchasers to determine requirements and the duty of manufacturers to define the constraints for their products regarding what configurations are valid. Invalid configuration attempts may result in an error response.

### ***Defining “Percent Available VARs,” the Array Y-Values***

The Y-values in the Volt-VAR settings are defined as “Percent of Available VARs”, where “Available VARs” implies whatever the DER is capable of providing at the moment, without compromising Watt output. In other words, Watt output takes precedence over VARs in the context of this function.

One effect of this definition is that VAR output may then vary in real-time in response to an intermittent PV source, as illustrated in Figure 11-6.

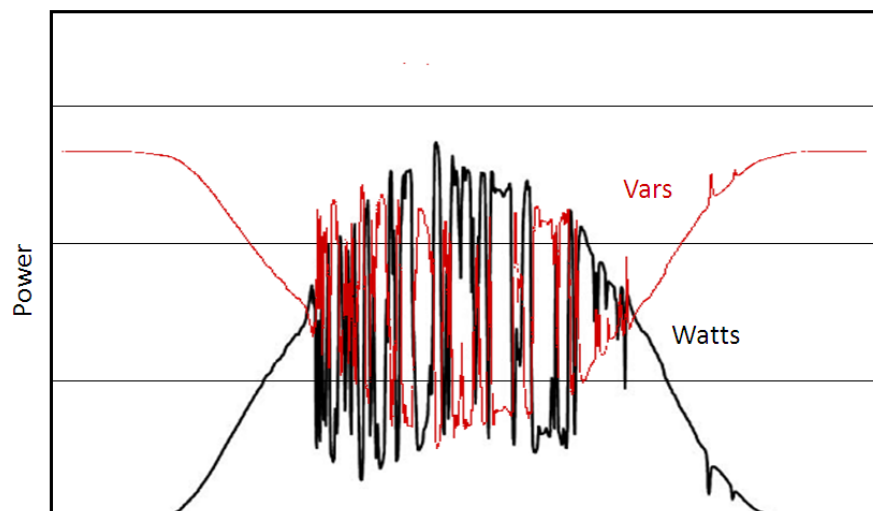

**Figure 11-6**  
**Illustration of VAR output varying inversely with watt output**

This Volt-VAR function may be used in conjunction with Volt-Watt functions or other Watt-limiting functions defined elsewhere in this work, to assure VAR availability when needed, but this Volt-VAR function alone does NOT reduce Watt levels in order to produce VARs.

### ***Defining “Percent Voltage,” the Array X-Values***

As defined previously in the “Device Limits Settings” document from this initiative’s work, each DER will locally compute an “Effective Percent Voltage” based on its real-time local voltage measurement, nominal voltage setting, and offset voltage setting, as:

$$\text{Effective Percent Voltage} = 100\% * (\text{local measured voltage} - V_{\text{RefOfs}}) / (V_{\text{Ref}})$$

The outstation shall compare this “Effective Percent Voltage” Value to the voltages (X-Values) in the curve, such that the X-Values of the curve points shall be calculated as follows:

$$\text{Percent Voltage (X-Value of Curve)} = (\text{Voltage at the Curve Point} / V_{\text{Ref}}) * 100\%$$

Such that a “Percent Voltage” value of 100% represents the desired behavior when the voltage is exactly at the systems nominal or reference value.

This calculation permits the same configuration curves to be used across many different DER without adjusting for local conditions at each DER. For example, a utility might create a general “normal operation” Volt-VAR curve that is to be used across many different DER. This works, even though the actual nominal voltage might be 240 at some DER and 480V at others. Each DER is configured with a VRef, and VRefOfs (see the “Device Limits Settings” document) such that the same Volt-VAR curve works for all.

### ***Additional Parameters Affecting Volt-VAR Mode Settings***

Each Volt-VAR Mode shall have, in addition to the curve array, the following:

- **Timeout Window:** A time, after which the Volt-VAR mode is disabled. This timeout window begins when the mode becomes effective (as a result of a direct command or schedule). A value of zero shall be used to indicate that the setting does not expire.

- **Ramp Rates:** The maximum rate at which VAR output may transition from its prior value to its new target value when this mode first becomes effective. This setting does NOT affect the ramp rate of VAR output in response to varying voltage or varying availability of VARs (e.g. from a variable PV source). Similar to other functions, this includes four ramp rates depending on whether the system is charging or not and whether the change is an increase or decrease.
  - Ramp Rate – Increasing
  - Ramp Rate – Decreasing
  - Ramp Rate – Increasing, Charging
    - Storage Systems Only
  - Ramp Rate – Decreasing, Charging
    - Storage Systems Only

### ***Modes for Volt-VAR Management***

As mentioned above, each Volt-VAR curve setting should be considered a “Mode”. A DER can be configured with multiple Volt-VAR modes, each having its own curve settings Time\_Window and Ramp\_Rate. The maximum number of configurable Volt-VAR modes will be determined by the manufacturer or particular protocol mapping.

In this way, DER devices in the field may be pre-configured with curve settings (a potentially tedious process) and then managed during run-time using a simple command to “Go to Volt-VAR Mode 1”.

All DER on a particular feeder or line segment could be addressed as a group (broadcast) and instructed to go to Volt-VAR Mode 2. Each individual DR in such a situation might have a unique configuration curve for their Mode 2 behavior.

As an example of how this capability could be used, consider for example, that the DER closest to the substation could have one optimal Volt-VAR curve setting, and the DER at the end of the line could have another, with those in between varying between the two. If switches then reconfigure this circuit to feed it from the other end, then suddenly the DER that was closest to the substation has become the end of the line. In this case, the utility could associate one switch arrangement with Volt-VAR mode 1 and another with Volt-VAR mode 2. Each DER could then be pre-configured with two different Volt-VAR curves. At the time of a switch operation, all the DER on that circuit could be sent a single common broadcast to “Go to Volt-VAR Mode 2”, and result in each DER changing to its unique alternate mode of operation.

Additional examples could be to have different modes for different times of day (on peak vs. off peak) or different situational conditions, such as a transmission VAR contingency.

In order to manage these Volt-VAR modes, an additional parameter shall be defined that activates this Intelligent Volt-VAR Function, by enabling a Mode.

### ***Summary of Communication Configuration Parameters to Support Volt-VAR Modes***

Table 11-1 summarizes the configuration data identified in the descriptions in the sections above.

**Table 11-1**  
**Summary configuration data for the intelligent volt-VAR modes function**

	Configuration Item	Description
1	Enable/Disable Volt-VAR Mode “n”	A setting to enable or disable the Volt-VAR function, instructing: The Boolean, enable or disable the function and... The Mode number These may be a single communication/command or separate according to the particular communication protocol mapping
2	Y-Axis Scaling	A setting for users to choose the y-axis of the Volt-VAR curve. Four options are currently used in the industry: <ol style="list-style-type: none"> <li>1. Percent of Maximum Rated Active Power</li> <li>2. Percent of Maximum Rated Reactive Power with VARS precedence</li> <li>3. Percent of Maximum Rated Reactive Power, with Watts Precedence</li> <li>4. Percent of Maximum Available Reactive Power, with Watts Precedence</li> </ol>
3	Volt-VAR Mode 1 Array	A variable length two-dimensional array of points. Each point consisting of a Percent Voltage (X-value) and a Percent Available VARs (Y-value).
4	Volt-VAR Mode 1 Array Length	The number of points in the array.
5	Timeout_Window for Volt-VAR Mode 1	The time which the mode remains in effect once enabled. 0 = no timeout.
6	Ramp_Rate for Volt-VAR Mode 1	The maximum rate at which VAR output may change at the time the mode is first made effective.
7 -X	Repeat of item 2-5 for each additional Volt-VAR Mode	

**Schedules for Volt-VAR Modes**

In addition to direct communication to change Volt-VAR Modes, a schedule may be used to manage which mode is in effect at any time. The use of schedules will not affect the communication to define Volt-VAR curves and associated information as outlined in Table 11-1.

Schedules will provide the same effect as item 1 in Table 11-1, assigning which Volt-VAR mode shall be in effect (if any) at any time. At a minimum, it is expected that schedules will allow for daily, weekly, or seasonal recurrence (looping).

This function will utilize the existing scheduling mechanisms that exist in most communication protocols, so no attempt is made herein to establish a new scheduling mechanism. At schedule transition points where the Volt-VAR mode changes, the “Ramp Rate” parameter for the mode that is taking effect shall apply. Likewise, if a Volt-VAR mode has a Timeout\_Window that expires prior to its scheduled period ending, it shall stop functioning (ramp down) and no Volt-VAR mode will be active until the next schedule change.



# 12

## VOLT-WATT FUNCTION

### Scope of This Function

This function is intended to provide a flexible mechanism through which a general Volt-Watt function could be configured, if so desired. It is not intended to suggest that such a function is necessary or to specifically define how it should be configured if used.

### Requirements/Use Cases

The context for the inclusion of this function in this Phase 2 project includes a variety of needs that were expressed by utilities during the face-to-face workshop held in Denver in 2010. For example:

- **High Penetration at the Distribution Level, Driving Feeder Voltage Too High.** Some utilities described circumstances where high PV output and low load is causing feeder voltage to go too high at certain times. Existing distribution controls are not able to prevent the occurrence.
- **Localized High Service Voltage.** Several utilities described circumstances where a large number of customers served by the same distribution transformer have PV, causing local service voltage that is too high. The result is certain PV inverters that do not turn on at all.

### Prior Bodies of Work

Although the Phase 1 work defined a method for fixed-setting of the maximum power output from a PV/Storage system to some level less than 100% of the capability, the needs identified above are better served by an automatic function. Specifically, the workshop attendees identified a priority need for an autonomous Volt-Watt function, whereby an inverter system could gradually reduce its own maximum power output as the voltage at the PCC exceeds a configurable, utility defined limit.

The IEC TC57 WG17 has not yet considered this function.

### Proposal

It is proposed to utilize a “configurable-curve” approach for this function, maintaining consistency with the Volt-VAR curve mechanism defined in Phase 1 and already in the specification. This mechanism allows the inverter to be configured using an array of points, where the points define a piece-wise linear “curve” that establishes an upper limit on Watt output as a function of the local voltage. Figure 12-1 illustrates the concept.

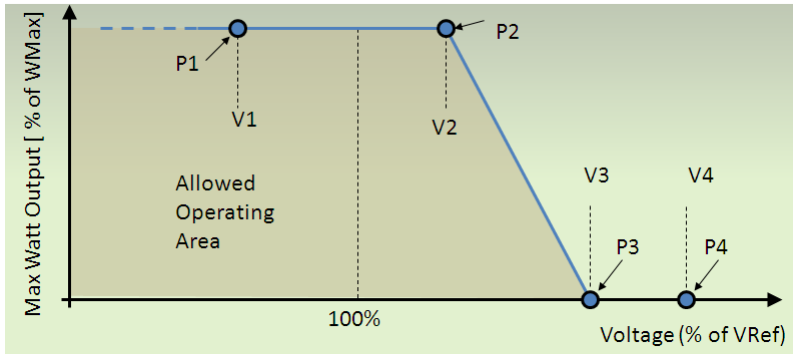

**Figure 12-1**  
**Example configuration curve for maximum watts vs. voltage**

The exact curve shape shown in Figure 12-1 is only an example. The array of points could be chosen so as to produce whatever behavior is desired. By definition of this function, the curve extends horizontally below the lowest voltage point and above the highest voltage point until such level that some other operational limit is reached. This means that in this example, point 1 and point 4 could be deleted, leaving only two configuration points, with no change in the resulting function.

In this configuration, the voltages are to be represented in the form of “Percent of VRef”, consistent with the voltage axis on the previously defined Volt-VAR curves. “VRef” is a single global setting for the inverter that represents the nominal voltage at the Point of Common Coupling. See the “Configuration Curve Axis Definitions” section below for further explanation. For example, an inverter might be configured for a VRef of 480Vac, and have a Volt-Watt curve as shown in Figure 12-1, with V2 = 105% and V3 = 110%. In which case, Watt-output reduction would begin above 504Vac and be reduced to zero above 528Vac.

In similar fashion, the Vertical axis in Figure 12-1 is to be represented in terms of “Percent of Watts Max”, where “Watts Max” is the inverter’s maximum set Wattage capability (WMax).

In addition to this curve configuration, it is proposed that the Volt-Watt configuration also include a time window, ramp time, time-out window, a filter time constant and a gradient limit, as defined in Table 12-1.

### **Defining “Percent Voltage,” the Array X-Values**

As defined previously in the “Device Limits Settings” document from this initiative’s work, each DER will locally compute an “Effective Percent Voltage” based on its real-time local voltage measurement, nominal voltage setting, and offset voltage setting, as:

$$\text{Effective Percent Voltage} = 100\% * (\text{local measured voltage} - V_{\text{RefOfs}}) / (V_{\text{Ref}})$$

The inverter shall compare this “Effective Percent Voltage” Value to the voltages (X-Values) in the curve, such that the X-Values of the curve points shall be calculated as follows:

$$\text{Percent Voltage (X-Value of Curve)} = (\text{Voltage at the Curve Point} / V_{\text{Ref}}) * 100\%$$

Such that a “Percent Voltage” value of 100% represents the desired behavior when the voltage is exactly at the systems nominal or reference value.

This calculation permits the same configuration curves to be used across many different DER without adjusting for local conditions at each DER. For example, a utility might create a general “normal operation” Volt-VAR curve that is to be used across many different DER. This works, even though the actual nominal voltage might be 240 at some DER and 480V at others. Each DER is configured with a VRef, and VRefOfs (see the “Device Limits Settings” document) such that the same Volt-VAR curve works for all.

**Application to Storage Systems (Two-Way Power Flows)**

It is proposed that limits for Watts-absorbed by a DER be managed by a separate setting than that used for Watts-produced.

The method and parameters of the “Absorbed Volt-Watt” function would be identical to those for the Produced Volt-Watt function, except that a typical curve setting might look as illustrated in Figure 12-2.

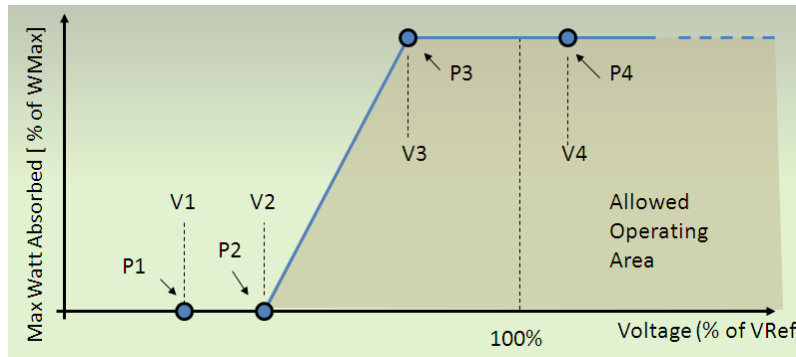

**Figure 12-2**  
**Example configuration curve for maximum watts absorbed vs. voltage**

There may be a “Watts-Produced versus Voltage” mode and a “Watts-Absorbed versus Voltage” mode effective at the same time, each limiting the power flow in only one direction.

The “Watts-Absorbed versus Voltage” function uses a duplicate of the settings identified in Table 12-1 at the end of this section.

**Limiting the Rate of Change of the Function**

This function ultimately results in an upper limit on the Watts produced by the inverter, and likewise a limit on Watts absorbed for energy storage systems. Two mechanisms are proposed for limiting the rate of change of these limits. These may be configured such that they are used individually, together, or not at all.

**Low-Pass Filter**

The Low-Pass filter is a simple first-order filter with a frequency response magnitude given by:

$$\left| \frac{Output}{Input} \right| = \frac{1}{\sqrt{1 + (\omega\tau)^2}}$$

Where  $\omega = 2\pi * \text{frequency}$  and  $\tau = \text{the time constant of the filter}$ .

And in the time domain:

$$Output = Input * (1 - e^{-\frac{t}{\tau}})$$

The time-response of such a filter to a step change in the input is as illustrated in Figure 12-3.

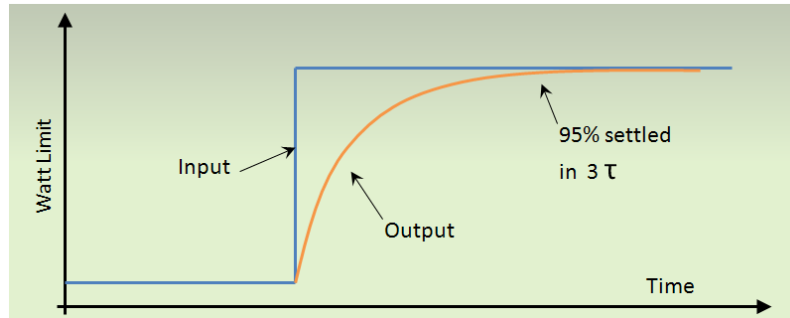

**Figure 12-3**  
**Time domain response of first order low pass filter**

The configuration parameter for this filter is a time, in seconds, in which the filter will settle to 95% of a step change in the input value. This is equivalent to  $3\tau$ .

### Rate of Change Limiter

The rate of change limiter adds an alternative method, or an additional degree of freedom, for how the function's time response may be limited. This function simply establishes maximum values for the rising and falling rate of the Watt limits as:

$$\frac{dWattLimit}{dt} \leq Rise\_Limit \quad \text{and} \quad \frac{dWattLimit}{dt} \geq Fall\_Limit$$

Where Rise\_Limit and Fall\_Limit are configuration parameters in units of %WMax/Second (see Table 12-1)

### **Using Modes for Handling of Multiple Volt-Watt Configurations**

Just as with the Volt-VAR modes defined in Phase 1, it is proposed that inverters may accept and store multiple Volt-Watt curve configurations, each constituting a Volt-Watt "Mode". In this way, an inverter may be commanded to change from one Watts-Voltage Mode to another by simply setting the desired pre-configured mode to "active". Different inverters may have specific tailored curve shapes for a given mode, but all may be addressed in a single broadcast or multicast command to change the Volt-Watt mode.

There are multiple scenarios in which different Volt-Watt modes may be desired. For example, a DER that is sometimes connected near the sourcing substation, and sometimes at the end of the line due to distribution switching, might be best managed with different settings in each of the two conditions. "Mode" settings may help prepare smart inverters for integration with advanced distribution automation systems. Another example may be intentional islanding, where different settings for the inverter are desired when operating as part of an island.

This “Mode” concept is facilitated by adding to the list of configuration parameters listed in Table 12-1, a “Mode number” (unique ID for the mode) and a single global field for the “Currently Active Watt Produced-Voltage Mode”.

### Scheduling Volt-Watt Modes

Just as with the Volt-VAR modes defined in Phase 1, it is proposed that the Volt-Watt modes be schedulable. The schedules will essentially define which Volt-Watt mode is in effect at a given time.

### Resulting Block Diagram

The combination of a setting for maximum Watts-Produced vs. Voltage and another for maximum Watts-Absorbed vs. Voltage results in a functional block diagram as in Figure 12-4. Note that for either function, several mode configurations might be stored in the inverter, and separate mode selection switches exist for each.

The diagram presently illustrated both a “steady-state filter” on the voltage input, and rate of change limitations on the effective operating bounds (Max Watts-Produced, and Max Watts-Absorbed). The configuration data depicted in Table 12-1 indicates that each rate-of-change limiter would have separate rising and falling limits, as shown.

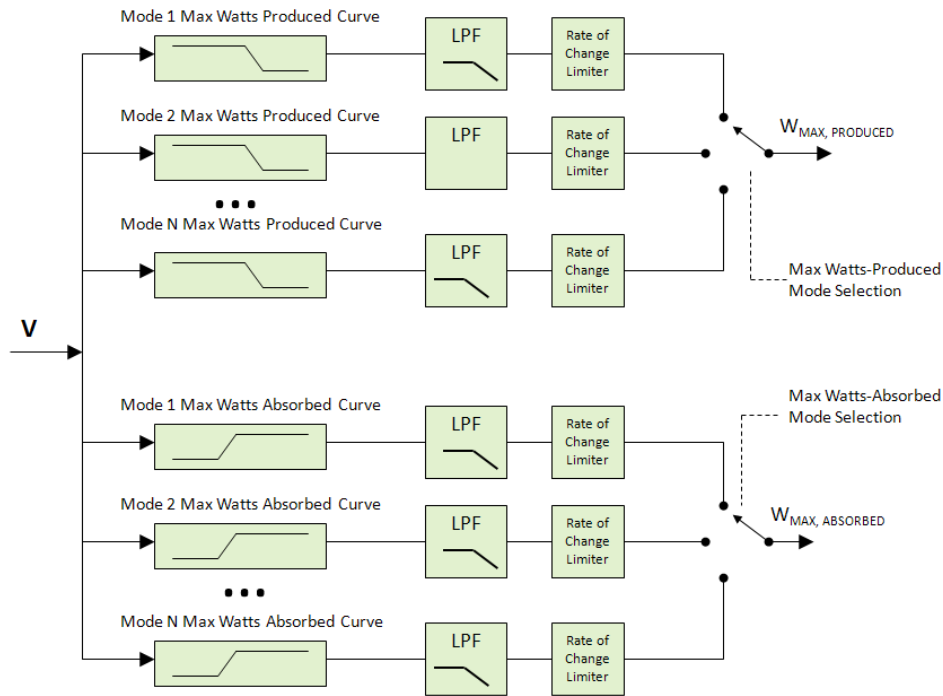

**Figure 12-4**  
Overall functional block diagram

### Resulting Configuration Data

The resulting configuration data for this function, as described, is summarized in Table 12-1. Note that this data set is replicated for each Watts-Delivered and Watts-Absorbed mode that is defined.

**Table 12-1**  
**Summary configuration data for one volt-watt mode**

Parameter	Description	Location of Parameters (local means bound to function)
Enable/Disable	This is a Boolean that enables / disables this Volt-Watt Mode	Local
Number of Array Points	The number of points in the Volt-Watt Curve Array (N points)	Local
Array Voltage Values	A length=N array of “percent of VRef” values	Local
Array Wattage Values	A length=N array of “Percent of WMax values	Local
Randomization Time Window	Delay before a new command or newly activated mode begins to take effect	Local with Global Default
Mode Transition Ramp Times	Rate of change limit for new commands as they take effect. This ramp time only manages the rate at which Watt output may transition to a new level when a configuration change is made (by communication or by schedule). It does <u>not</u> affect the rate of change of Watt output in response to voltage variations during normal run time.	Local with Global Default
Time Out	Duration that a new command remains in effect	Local with Global Default
Maximum Watt Capability (WMax)	Configured Value. Defined in Phase 1 work	Global
VRef	Reference Voltage. Defined in Phase 1 work	Global
VRefOfs	Reference Voltage Offset. Defined in Phase 1 work	Global
Fall_Limit	The maximum rate at which the Max Watt limit may be decreased in response to changes in the local voltage. This is represented in terms of % of WMax per second.	Local
Rise_Limit	The maximum rate at which Max Watt limit may be increased in response to changes in the local voltage. This is represented in terms of % of WMax per second.	Local
Fall_Limit_Cha	The maximum rate at which the Max Watt limit may be decreased in response to changes in the local voltage. This is represented in terms of % of WChaMax per second. This parameter only applies to energy storage systems.	Local
Rise_Limit_Cha	The maximum rate at which Max Watt limit may be increased in response to changes in the local voltage. This is represented in terms of % of WChaMax per second. This parameter only applies to energy storage systems.	Local
Low Pass Filter Time	Equal to three time-constants ( $3\tau$ ) of the first order low-pass filter in seconds (the approximate time to settle to 95% of a step change).	Local

### Interaction of this Function with the Intelligent Volt-VAR Function

The Volt-VAR modes that were described in Phase 1 of this project were designed in such a way that Watts take precedence over VARs. The vertical axis of any Volt-VAR curve can be thought of as the “requested” VAR level, with the understanding that an inverter that is producing its full Watt capacity at any point in time may have no VARs to offer.

The interaction between the Volt-VAR function and the present Watt-Volt function is direct and intentional. The vertical axis of the Volt-VAR function’s configuration curve was defined as “percent of available VARs”, meaning that Watts production always takes precedence over VARs, regardless of voltage. This agreement came from focus group discussion that included the consideration of the interests of the PV owner, the preference for clean watts generation in general, and the recognition that in almost all cases, there is a good margin between the inverter rating and the peak array output, meaning that significant VAR production capability usually exists.

When this definition of the Volt-VAR function is coupled with a Watt-Volt function, one gains the ability to back off on watts as voltage rises, forcing more VAR capability to be available, and in effect enabling the Volt-VAR function to be active and produce VARs even in situations when the array output is capable of driving the full rating of the inverter.

As an example, consider an inverter with the two functions shown in Figure 12-5 (top = Volt-VAR function, Bottom = Volt-Watt function), both active simultaneously.

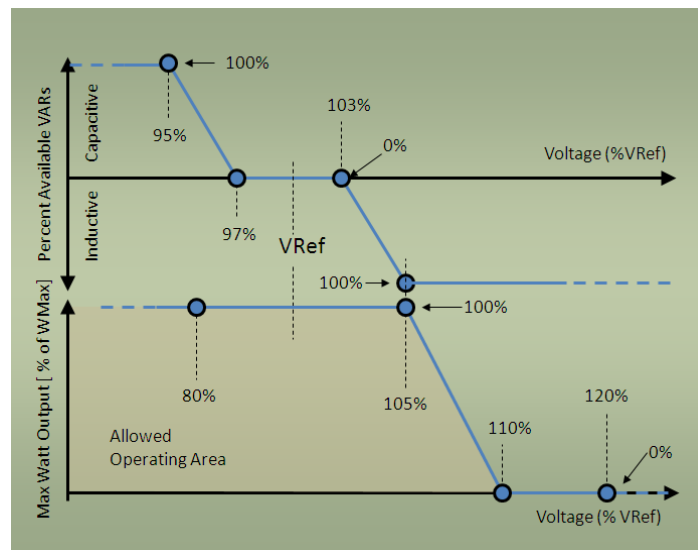

**Figure 12-5**  
Example settings for volt-VAR and volt-watt modes

Given this configuration, consider two scenarios:

1. The PV panel output is producing enough Watts to drive the inverter to its Watts limit. In this case, the output power and VARs would be as indicated in Figure 12-6 as a function of voltage. In this case, the VAR output is zero until such time as the Wattage output is reduced by the Volt-Watt function. As voltage moves higher, ability to generate VARs increases (per constant VA).

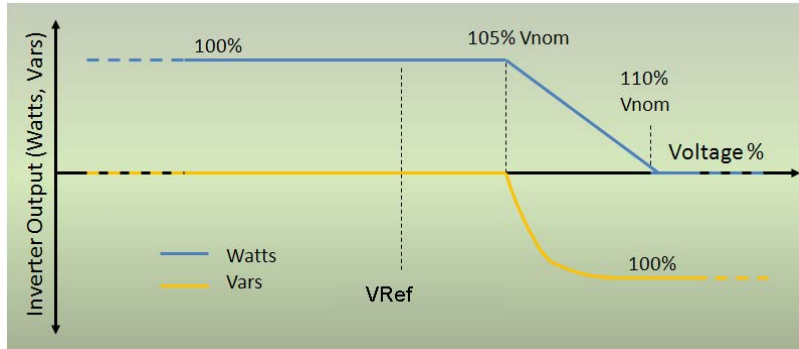

**Figure 12-6**  
**Inverter output with PV panel output at 100%**

2. PV panel output is producing enough Watts to drive the inverter to 80% of its Watts limit. In this case, the output power and VARs would be as indicated in Figure 12-7 as a function of voltage. In this case, the VAR output is limited to 60% (constant VA circle for an 80% Watt output) until Watts become reduced, at which point the VAR capability increases to 100%.

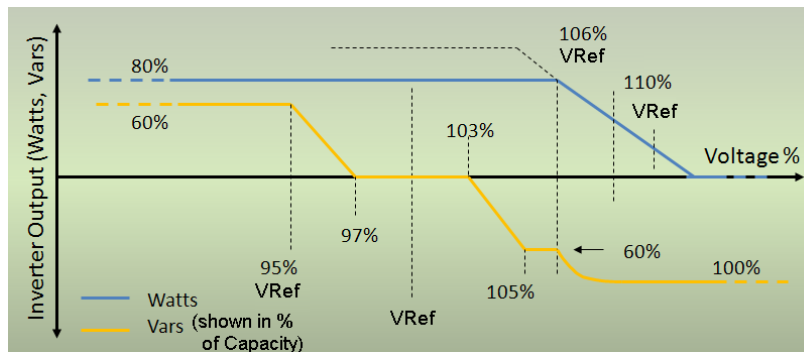

**Figure 12-7**  
**Inverter output with PV panel output at 80%**

# 13

## FREQUENCY-WATT FUNCTION

### Scope of This Function

This function is intended to provide a flexible mechanism through which a general Frequency-Watt function could be configured, if so desired. It is not intended to suggest that such a function is necessary or to specifically define what values to set or how it should be configured if used.

### Requirements/Use Cases

The context for the inclusion of this function in this Phase 2 project includes a variety of needs that were expressed by utilities during the face-to-face workshop held in Denver in 2010. For example:

- **Short-Term (Transient) Frequency Deviations.** Under certain circumstances, system frequency may dip suddenly. Some discussion of this type of event may be found in reports from PNNL's Grid Friendly Appliance project.<sup>3</sup> Autonomous responses to such events are desirable because response must be fast to be of benefit.
- **Long-Term Frequency Deviations or Oscillations.** Particularly in smaller systems or during islanded conditions, frequency deviations may be longer in duration and indicative of system generation shortfalls or excesses relative to load.

### Prior Bodies of Work

The IEC TC57, WG17 has been working to codify certain advanced inverter functions. The Phase 1 work from the smart inverter communication initiative provided some beginning reference materials to the IEC, and the working group has continued identifying several additional needs, including a Frequency-Watt function. This IEC work, when completed, will be documented as 61850-90-7 (not publicly available at the time of this writing). It includes consideration of German medium voltage grid codes which specify a particular frequency-watt behavior. The proposed "Frequency-Watt Function 1" below is derived from those codes.

There is also a recommendation for a second function, called "Frequency-Watt Function 2". This function is more generic and flexible, and is derived from prior work of this project team in the areas of Volt-VAR and Volt-watt functions.

The rationale for defining both of these functions is that the second has the flexibility to be used for many different behaviors and defines two-way power flow capability that will be needed for energy storage systems (i.e. both over and under frequency, with corresponding curtailments of both watts produced and watts absorbed). The first function, on the other hand, is simpler and requires less memory in the end device. Manufacturers may choose to implement one, the other,

---

<sup>3</sup> [http://www.pnl.gov/main/publications/external/technical\\_reports/PNNL-17079.pdf](http://www.pnl.gov/main/publications/external/technical_reports/PNNL-17079.pdf)

or both. The functions are mutually exclusive in operation, with only one or the other intended to be in effect q at any time.

## Proposal

### **Frequency-Watt Function 1**

These functions address the issue that high frequency often is a sign of too much power in the grid, and vice versa. One method for countering the over-power problem is to reduce power in response to rising frequency (and vice versa if storage is available). Adding hysteresis provides additional flexibility for determining the active power as frequency returns toward nominal.

Table 13-1 shows the Function 1 settings for the active power reduction by frequency.

The parameters for frequency are relative to nominal grid frequency (ECPNomHz). The parameter HzStr establishes the frequency above nominal at which power reduction will commence. If the delta grid frequency is equal or higher than this frequency, the actual active power will be frozen, shown as  $P_M$ . If the grid frequency continues to increase, the power will be reduced by following the gradient parameter (WGra), defined as percent of  $P_M$  per Hertz. This reduction in output power continues until either the power level is zero or some other limit (e.g. a 1547 turn off limit) is reached.

The parameter HystEna can be configured to activate or deactivate hysteresis. When hysteresis is activated, active power is kept reduced until the delta grid frequency reaches the delta stop frequency, HzStop.

Whether or not hysteresis is active, the maximum allowed output power will be unfrozen when the delta grid frequency becomes smaller than or equal to the parameter HzStop.

In order that the increase in power is not abrupt after releasing the snap shot value (frozen power) a time gradient is defined. The parameter HzStopWGra can be set in  $P_{max}/minute$ . Default is 10%  $P_{max}/minute$ .

**Table 13-1**  
**Frequency-watt function 1 settings**

Name	Description	Example Settings
WGra	The slope of the reduction in maximum allowed Watt output as a function of frequency	40% Pref/Hz
HzStr	The frequency deviation from nominal frequency (ECPNomHz) at which a snapshot of the instantaneous power output is taken as a maximum power output reference level (Pref) and above which reduction in power output occurs	0.2 Hz
HzStop	The frequency deviation from nominal frequency (ECPNomHz) at which curtailed power output may return to normal and the snapshot value is released	0.05 Hz
HystEna	A boolean indicating whether or not hysteresis is enabled	On
HzStopWGra	The maximum time rate of change at which power output returns to normal after having been curtailed by an over frequency event	10% $P_{max}/minute$

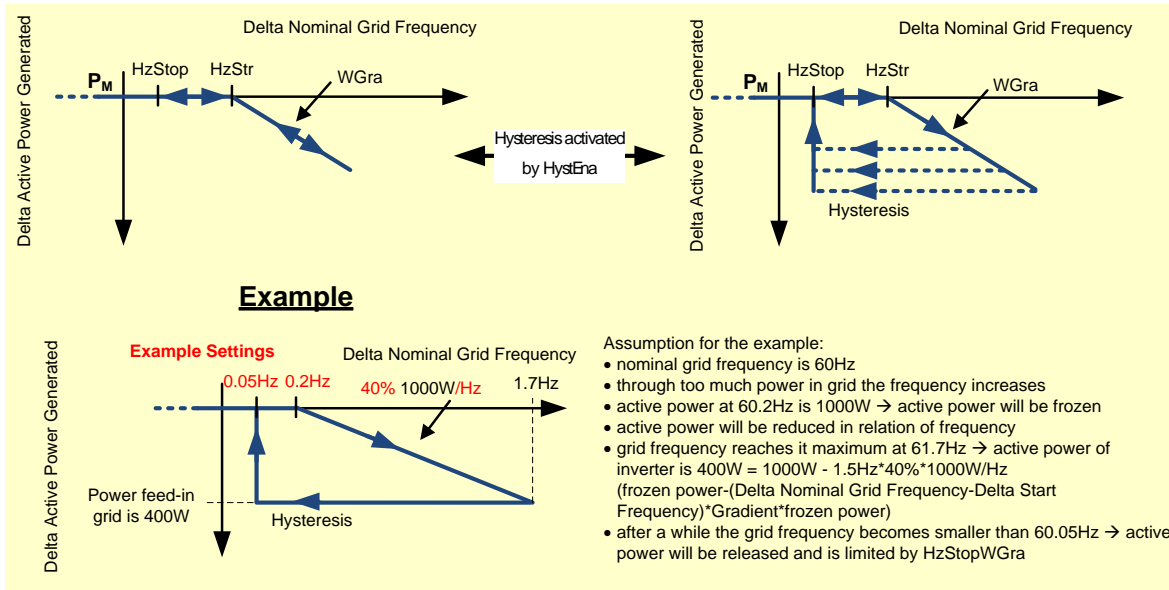

**Figure 13-1**  
Frequency-watt function 1 visualization

### Frequency-Watt Function 2

This function provides a configurable curve-shape method for establishing the desired Frequency-Watt behavior in the end device. The general approach follows that of the previously defined Volt-Watt function.

### Modes

As with the Volt-VAR modes, multiple Frequency-Watt Function 2 modes may be configured into an inverter. For example, the desired frequency-watt curve-settings might be different on-peak vs. off-peak, or different when islanded vs. grid connected. A simple mode change broadcast could move the inverters from one pre-configured frequency-watt mode to another.

### Basic Concept

The basic idea is illustrated in Figure 13-2.

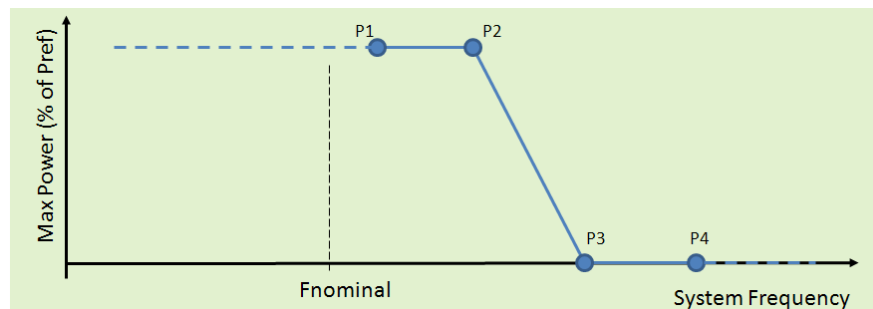

**Figure 13-2**  
Example of a basic frequency-watt mode configuration

The desired frequency-watt behavior is established by writing a variable-length array of frequency-watt pairs. Each pair in the array establishes a point on the desired curve such as those labeled in Figure 13-2 as P1-P4. The curve is assumed to extend horizontally to the left below the lowest point and to the right above the highest point in the array. The horizontal X-axis values are defined in terms of actual frequency (Hz). The vertical Y-axis values are defined in terms of a percentage of a reference power level (Pref) which is, by default, the maximum Watt capability of the system. WMax (defined in prior work), is configurable and may differ from the nameplate value. As will be explained later in this document, these Y-axis values are signed, ranging from +100% to -100%, with positive values indicating real power produced (delivered to the grid) and negative values indicating power absorbed.

### Optional Setting of a SnapShot Power Reference (Pref) Value

In some cases, it may be desirable to limit and reduce power output relative to the instantaneous output power at the moment when frequency deviates to a certain point. To enable this capability, each frequency-watt mode configuration may optionally include the following parameters.

**Snapshot\_Enable:** A Boolean, which when true, instructs the inverter that the Pref value (the vertical axis reference in Figure 13-2) is to be set to a snapshot of the instantaneous output power at a certain frequency point. When Snapshot is enabled, no reduction in output power occurs prior to reaching the Pref\_Capture\_Frequency

**Pref\_Capture\_Frequency:** The frequency setting, in hertz, at which the Pref value is established at the instantaneous output of the system at that moment. This parameter is only valid if Snapshot\_Enable is true.

**Pref\_Release\_Frequency:** The frequency setting, in hertz, at which the Pref value is released, and system output power is no longer limited by this function. This parameter is only valid if Snapshot\_Enable is true.

### Optional Use of Hysteresis

Hysteresis can be enabled for this frequency-watt function in the same way as with the Volt-Watt function defined previously. Rather than the configuration array containing only points incrementing from left to right (low frequency to high frequency), as indicated in Figure 13-2, hysteresis is enabled by additional points in the configuration array which progress back to the left. Figure 13-3 illustrates this concept.

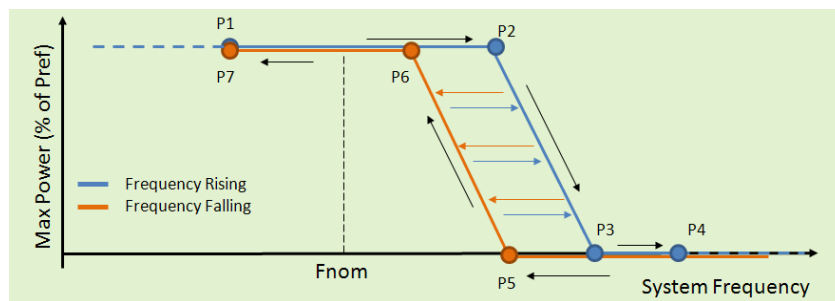

**Figure 13-3**  
Example array settings with hysteresis

In this case, the points in the configuration array can be thought-of as the coordinates for an X-Y plotter. The pen goes down on the paper at the first point, then steps through the array to the last point, tracing out the resulting curve. As with any configuration (including those without hysteresis), inverters must inspect the configuration when received and verify its validity before accepting it. The hysteresis provides a sort of dead-band, inside which the maximum power limit does not change as frequency varies. For example, in Figure 13-3, if frequency rises until the max power output is being reduced (somewhere between points P2 and P3), but then the frequency begins to fall, the maximum power setting would follow the light orange arrows horizontally back to the left, until the lower bound is reached on the line between points P5 and P6.

The return hysteresis curve does not have to follow the same shape as the rising curve. Figure 13-4 illustrates an example of such a case.

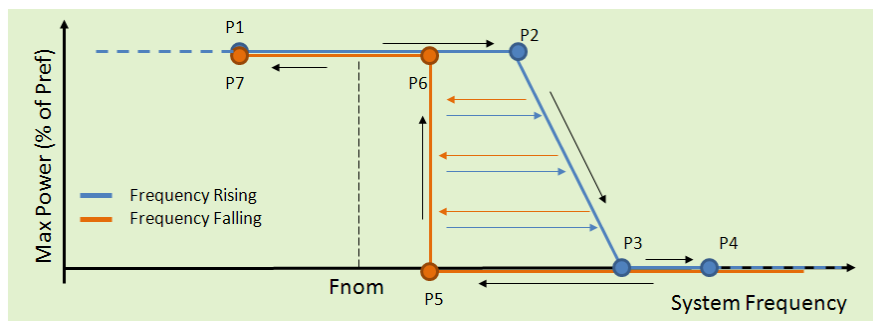

**Figure 13-4**  
**Example of an asymmetrical hysteresis configuration**

### Controlling Ramp Time

It may be desirable to limit the time-rate at which the maximum power limit established by these functions can rise or fall. To enable this capability, each frequency-watt mode configuration will include the following parameters, in addition to the array.

**Ramp\_Time\_Increasing** and **Ramp\_Time\_Decreasing**: The maximum rates at which the maximum power limit established by this function can rise (defined as moving away from zero power) or fall (defined as moving toward zero power), in units of %WMax/second.

### Supporting Two-Way Power Flows

Some systems, such as energy storage systems, may involve both the production and the absorption of Watts. To support these systems, a separate control function is defined, which is identical to that described above, except the vertical axis is defined as maximum watts absorbed rather than maximum watts delivered. This allows for energy storage systems to back-off on charging when grid frequency drops, in the same way that photovoltaic systems back-off on delivering power when grid frequency rises. Figure 13-5 illustrates an example setting.

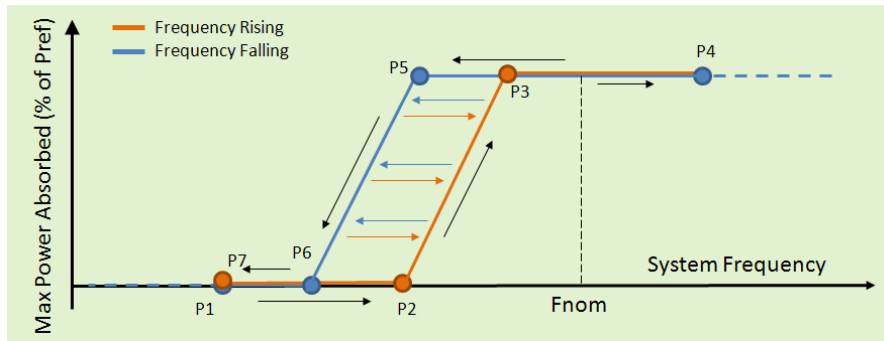

**Figure 13-5**  
**Example array configuration for absorbed watts vs. frequency**

A further characteristic of systems capable of two-way power flows is that the maximum power curtailment illustrated in Figure 13-2 through Figure 13-5 need not stop at 0%. It may pass through zero, changing signs, and indicating that power must flow in the opposite direction (unless prevented from doing so by some other hard limitation) as illustrated in Figure 13-6.

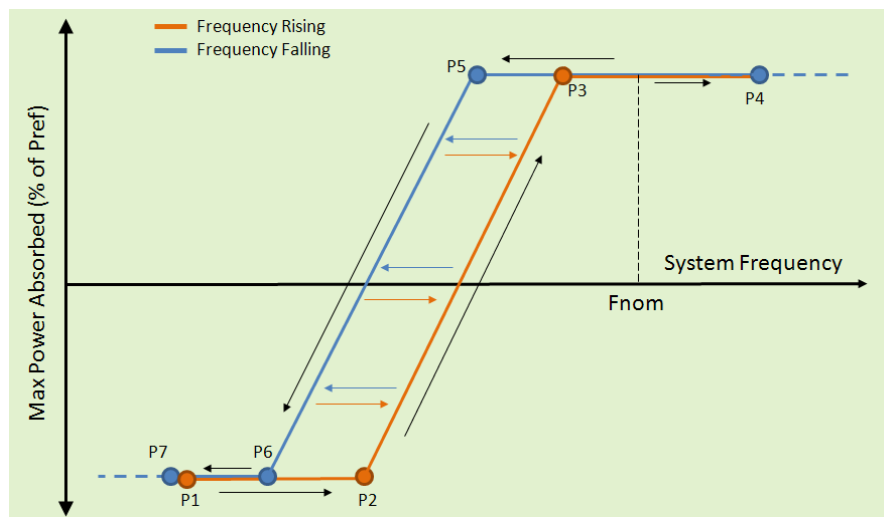

**Figure 13-6**  
**Example configuration for reversing sign on  $P_{\text{ABSORBED}}$  limit**

For example, an energy storage system may be in the process of charging, absorbing power from the grid. If the grid frequency then falls below normal, the maximum absorbed power level may begin to be curtailed. Once it has been curtailed to zero, if the frequency keeps falling, the system could be configured to produce watts, delivering power to the grid. Likewise, an energy storage system could curtail discharging if the grid frequency rises too high, and begin charging if frequency continues to rise further. These array configurations would utilize the signed nature of the array Y-values, as mentioned above.

### **Configuration Data**

The resulting configuration data for this function, as described, is summarized in Table 13-2.

**Table 13-2**  
**Summary configuration data for each frequency-watt function (per mode)**

Parameter	Description	Location of Parameters (local means bound to function)
<b>Frequency-Watt Function 1</b>		
WGra	The slope of the reduction in maximum allowed Watt output as a function of frequency (%WMax/sec)	Local
HzStr	The frequency deviation from nominal frequency (ECPNomHz) at which a snapshot of the instantaneous power output is taken as a maximum power output reference level (Pref) and above which reduction in power output occurs (Hz)	Local
HzStop	The frequency deviation from nominal frequency (ECPNomHz) at which curtailed power output may return to normal and the snapshot value is released (Hz)	Local
HystEna	A boolean indicating whether or not hysteresis is enabled	Local
HzStopWGra	The maximum time rate of change at which power output returns to normal after having been curtailed by an over frequency event (Hz)	Local
<b>Frequency-Watt Function 2</b>	<b>Note: The following parameter set exists once for each “Frequency-Watt Produced” mode, and once for each “Frequency-Watt Absorbed mode”</b>	
Configuration Array	The variable length array of Frequency-Watt pairs that traces out the desired behavior. (%PRef vs. Hz)	Local
Snapshot_Enable	A boolean determining whether snapshot mode is active	Local
Pref_Capture_Freq	The frequency at which the power reference point is to be captured if in snapshot mode (Hz)	Local
Pref_Release_Freq	The frequency at which the power reference point is to be released if in snapshot mode (Hz)	Local
Ramp_Time_Inc	The maximum time rate of increase in the max power limit associated with this mode configuration (%WMax/Second)	Local
Ramp_Time_Dec	The maximum time rate of decrease in the max power limit associated with this mode configuration (%WMax/sec)	Local
Ramp_Time_Cha_Inc	The maximum time rate of increase in the max charging limit associated with this mode configuration. Only applies to energy storage systems. (%WChaMax/Second)	Local
Ramp_Time_Cha_Dec	The maximum time rate of decrease in the max charging limit associated with this mode configuration. Only applies to energy storage systems. (%WChaMax/sec)	Local

Parameter	Description	Location of Parameters (local means bound to function)
<b>Frequency-Watt Function 1</b>		
Time_Window	This is a window of time over which the inverter randomly delays before beginning execution of the command. For example, an inverter given a new Volt-Watt configuration and a Time-Window of 60 seconds would wait a random time between 0 and 60 seconds before beginning the change to the new setting. The purpose of this parameter is to avoid large numbers of devices from simultaneously changing state if addressed in groups. (in seconds)	Local
Ramp_Time	This setting, which exists for most functions, is replaced by the separate Ramp_Tme_Inc,Ramp_Time_Dec, Ramp_Tme_Cha_Inc, and Ramp_Time_Cha_Dec settings for this function.	Not Used
Time-Out Window	This is a time after which the command expires. A setting of zero means to never expire. After expiration, the Volt-Watt curve would no longer be in effect. (in seconds)	Local

## Emergency Mode

IEC 61850 is introducing an emergency mode of this function. Emergency mode is a copy of the Frequency-Watt function that operates in the background at a higher priority than other functions. The parameters are identical however they are set to support frequency when frequency deviates largely. The normal Frequency-Watt function provides support for frequency within acceptable ranges however the Emergency Mode only supports frequency when grid frequency deviates from acceptable ranges. This mode is required in Europe and soon may be required by IEEE 1547.

## Relative Prioritization of Modes

Multiple modes which may act to limit Watt production are being defined by the Smart Inverter Communication Initiative, including the recent additions of the Volt-Watt and Frequency-Watt functions. The overall body of work will identify relative priorities for all overlapping functions.

In regards to Volt-Watt and Frequency-Watt functions, both of which may be simultaneously active, the one that indicates the lower max-power level (closest to zero) at any point in time is the one that establishes the limit at that time.

Chapter 25 in this report provides additional guidelines for the precedence/priority of multiple functions that may be simultaneously active.

# 14

## WATT-POWERFACTOR FUNCTION

### Scope of This Function

This function is intended to provide a flexible mechanism through which a general Watt-PowerFactor function could be configured, if so desired. It is not intended to suggest that such a function is necessary or to specifically define what values to set or how it should be configured if used.

### Requirements/Use Cases

None captured by the focus group.

### Prior Bodies of Work

The IEC TC57, WG17, while working to codify certain advanced inverter functions, identified and added this function. It was not discussed by the EPRI focus group, but is incorporated here for completeness and to maintain consistency as possible between these related bodies of work as they emerge.

### Proposal

As illustrated in Figure 14-1, this function will use the curve method used in other functions. The curve will be defined by writing an array of X, Y point pairs which create a piece-wise linear “curve”. The X-values of the array (the controlling parameter) will be the present real power output, expressed as a percentage of maximum nameplate real power output (WMax) and real power input (WChaMax) for energy storage systems charging. The Y-values of the array (controlled parameter) will be the power factor, expressed as a signed value greater than 0 and up to 1. The signed power factor value will be interpreted per the IEEE standard as defined in Chapter 9.

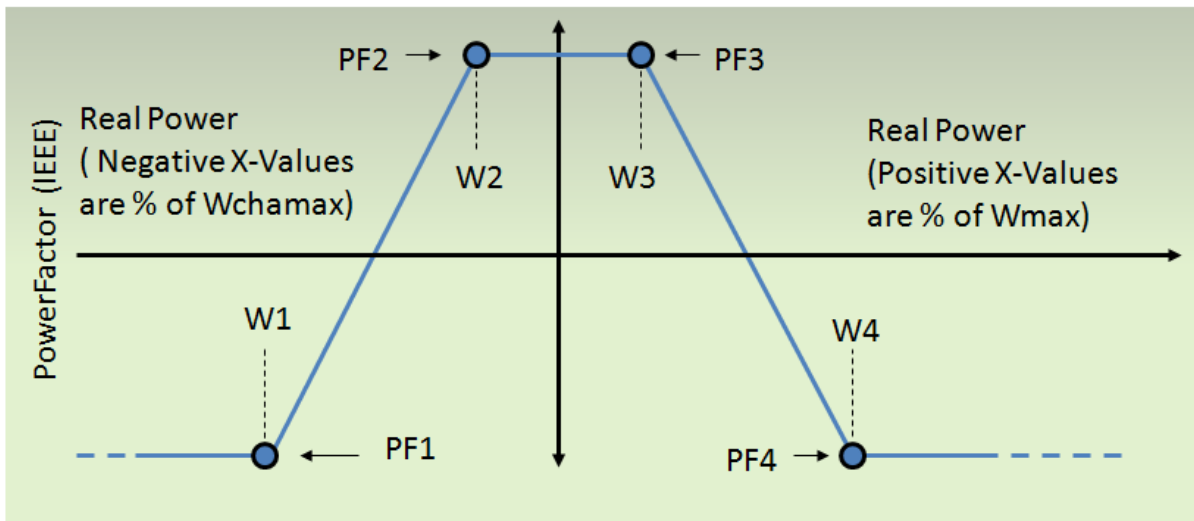

**Figure 14-1**  
**Example watt – power factor configuration**

As illustrated, the X-values for this configuration may be signed, with negative percentage values relating to Watts received from the grid, and being percentages of the maximum charging rate, WChaMax and positive percentage values relating to Watts delivered to the grid, and being percentages of the maximum real power output Wmax. For devices that only produce power (to the grid), configurations may be used that only include positive X-values.

Like other functions, this function will include settings for:

**Time\_window** – a time window over which a random delay will be applied prior to activating this function after the command is received or scheduled to take effect.

**Ramp Time** – Output Increasing: a time in seconds, over which the DER linearly places the new PF limit into effect when increasing output.

**Ramp Time** – Output Decreasing: a time in seconds, over which the DER linearly places the new PF limit into effect. (Optional)

**Ramp Time** – Input Increasing: a time in seconds, over which the DER linearly places the new PF limit into effect when decreasing input. Only applies to energy storage. (Optional)

**Ramp Time** – Input Decreasing: a time in seconds, over which the DER linearly places the new PF limit into effect when decreasing output. Only applies to energy storage. (Optional)

**Time\_out**: a time after which this function expires.

This function is mutually exclusive with the Volt-Var and other static Var curves.

# 15

## PRICE OR TEMPERATURE DRIVEN FUNCTIONS

### Scope of This Function

These functions are intended to provide a flexible mechanism through which price or temperature may act as the controlling variable for a curve-based control function.

### Requirements/Use Cases

None captured by the focus group.

### Prior Bodies of Work

The IEC TC57, WG17, while working to codify certain advanced inverter functions, identified and added this function. It was not discussed by the EPRI focus group, but is incorporated here for completeness and to maintain consistency as possible between these related bodies of work as they emerge.

### Proposal

This function is proposed to work by using a configurable array, just as with the volt-var or other array-based functions. As with the other curve-based functions, the settings would allow for a variable number of points and for hysteresis if desired.

An enumerated setting will be used to identify the X-variable (controlling parameter) of the array, whether price or temperature. The specific format and scaling of the X-variable will be implicit in the enumeration.

Likewise, the Y-variable (controlled variable) of the array will be identified by a separate enumeration, with format and scaling implicit in the enumeration. For example, the Y-values could be percentages of some maximum value, or an absolute value. If the output (Y-value) chosen is a percentage, it may require a reference value to be initialized before the curve should be enabled.



# 16

## LOW/HIGH VOLTAGE RIDE-THROUGH FUNCTION

### Scope of This Function

This proposal is for the Phase 2 Smart Inverter Communication Project, for the Low/High Voltage Ride-Through function (agenda item 3). This initiative is defining a toolkit of functions that are being defined using a standardized model which can then be mapped into a variety of protocols.

None of the functions being described through this initiative are necessarily “mandatory” from an implementation perspective – actually requiring certain functions to be implemented is the purview of regulators and of the purchasers of systems. The works into which this function will be added state that “if a function is to be implemented, then it must be implemented according to these specifications”.

This specification is intended to provide a flexible mechanism through which general Low/High Voltage Ride-Through (L/HVRT) behavior may be configured, if so desired. In this context, L/HVRT refers only to the connect/disconnect behavior of the distributed energy resource (DER), essentially defining the voltage conditions under which the DER may and must connect and disconnect.

This function defines only the mechanism through which the L/HVRT settings may be made and does NOT define the settings that would be used. Various countries, states, or other organizations such as the IEEE may issue specific L/HVRT requirements. The intention is that this function will be sufficiently flexible to support all such requirements.

### Requirements/Use Cases

The context for the inclusion of this function in this Phase 2 project was the expression of need by utilities during the face-to-face workshop held in Denver in 2010. Specifically, the following needs were represented:

- High Penetration Circumstances. Utilities expressed that existing IEEE 1547 rules are suitable for low penetration circumstances and that different L/HVRT settings may be needed for higher penetration circumstances. When the reliable delivery of power to loads becomes dependent on the generation of distributed resources, then fast disconnection during voltage disturbances may not be desirable. Rather, utilities need flexibility in configuring the behavior of devices under these circumstances.
- Systems with Poor Power Quality. It was noted that even when penetration levels of DER are not particularly high, under certain circumstances, it may be desirable that devices stay online longer during disturbances. A specifically cited example of this scenario is that of a small system, island, or long feeder in which voltage disturbances frequently occur. In these cases, flexibility in defining the dynamic connect and disconnect behaviors of inverters may be beneficial.

- Islanding. In scenarios where islanding can occur ride-through requirements may be modified to suit the variability and stability of islanded grids.

### **Prior Bodies of Work**

The initial contribution to this function has come from the IEC TC57, WG17. This group has been working to codify certain advanced inverter functions. This IEC work, when completed, will be documented as 61850-90-7 (publicly available at the time of this writing).

This description of L/HVRT has been enhanced since first published by EPRI, deferring to grid-codes on guidance for how curves are to be interpreted and adding to the reconnect timing parameters. In 2016 IEEE 1547 identified different regions which has led to some additional changes below.

### **L/HVRT Proposal**

This proposal provides a mechanism by which a wide range of settings may be passed to/from a smart inverter via a communication system in order to manage Low/High Voltage Ride-Through (L/HVRT) behavior. These settings represent the superset of needs that are presently known or anticipated. It is recognized that for many situations, the full capabilities supported herein may not be required and that, as a result, certain settings may not be used or required.

Trip and momentary cessation curves can be represented as piece-wise linear curves that define the regions associated with voltage and frequency trip and momentary cessation behavior. It is desirable to use a mechanism to represent the curves that is flexible and handles as many use cases as possible. For instance, the curves in European standards require “diagonal” lines that cannot be represented with rectangular regions.

Most threshold requirements can be represented by supplying a method to designate the following three regions: trip, may trip, momentary cessation. Each region is defined with a piece-wise linear curve demarcating the boundary, e.g., when crossing the may-trip curve, the DER is in the may-trip region.

The difference between trip and momentary cessation is the process of resuming operation once that region has been entered. This is different than the two types of disconnects mentioned in the Connect/Disconnect Function. In this case the exact resumption process may vary based on grid code and additional parameters but the general distinction is that resumption from momentary cessation may be done fully and immediately on leaving the region while resumption from trip may require additional considerations such as a delay and ramping operation. Due to the limits in some DER, galvanic isolation may or may not be provided on a trip.

The performance within each region is defined by grid code however the methods to communicate these regions to inverters is not. It is proposed to implement this function using configurable arrays as with prior functions from this initiative’s work. The arrays of X-Y points allow the user to define a piece-wise linear “curve” which defines the desired behavior or operating bounds. For LVRT, it is proposed that four curves may be defined, creating four regions (above and below the 100% line), as illustrated in Figure 16-1, including:

- High Voltage Must Trip

- High Voltage Momentary Cessation
- May Trip or Cease to Energize
- Low Voltage Momentary Cessation
- Low Voltage Must Trip

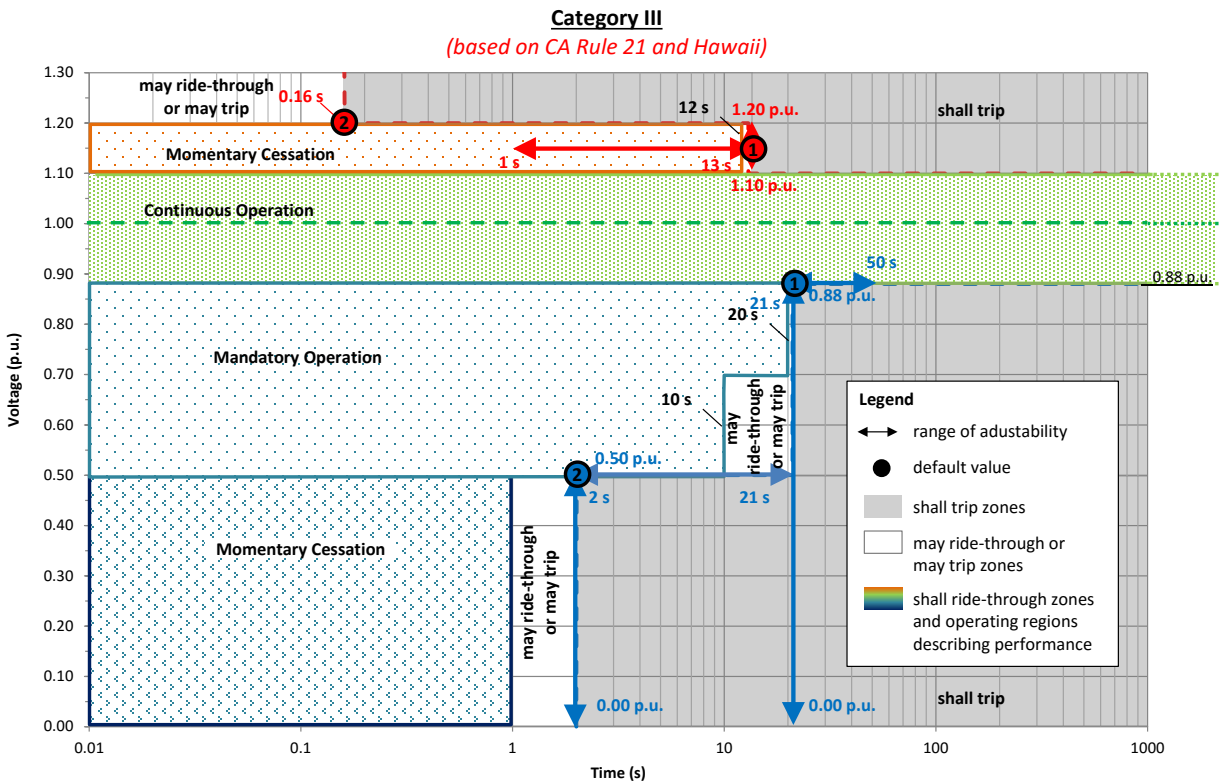

**Figure 16-1**  
An example concept of the different zones.<sup>4</sup>

Figure 16-1 illustrates the concept of the different zones. The actual H/LVRT values are provided by utilities, reflecting regulatory requirements and utility-specific requirements.

Each curve can be defined using an array. An example is provided in Table 16-1 for low and high voltage trip. The arrays can be interpreted using two similar approaches.

<sup>4</sup> J.C. Boemer et al., “Status of Revision of IEEE Std 1547 and 1547.1: Informal report based on IEEE P1547/Draft 5.0 (August 2016).” Paper presented at the 6th International Workshop on Integration of Solar Power into Power Systems, Vienna, Austria, November 14-15, 2016 [Online] [http://integratedgrid.com/wp-content/uploads/2016/10/EPRI\\_IEEE-P1547-and-P1547.1-Overview-August-2016\\_v2.pdf](http://integratedgrid.com/wp-content/uploads/2016/10/EPRI_IEEE-P1547-and-P1547.1-Overview-August-2016_v2.pdf)

**Table 16-1**  
**Example array for L/HVRT array**

Curve	Points
Low-Voltage Trip	(1.5, 0), (1.5, 0.5), (11, 0.5), (11, 0.7), (21, 0.7), (21, 0.88), (22, 0.88)
High-Voltage Trip	(0.16, 1.4), (0.16, 1.2), (13, 1.2), (13, 1.1), (14, 1.1)

First, the four arrays create five regions. Depending on what the inverter has observed on the grid it falls in one of the regions. In each region the inverter must take a specific action.

- Momentary Cessation – The DER shall cease to energize but shall not trip.
- Trip – The DER shall trip offline.

Second, the array can also be explained using a hierarchy approach. Referring to Figure 16-2, an inverter that observes grid voltage at 0.4 per-unit for 1.5 seconds has crossed both the low-voltage momentary cessation region and the low-voltage trip region. Which action should the inverter perform? The hierarchy for this approach is that trip takes precedence over momentary cessation. So if the inverter has cross both boundaries the inverter must trip.

The two examples above are just two approaches to translate the same arrays into the appropriate action. There is no difference in implementation.

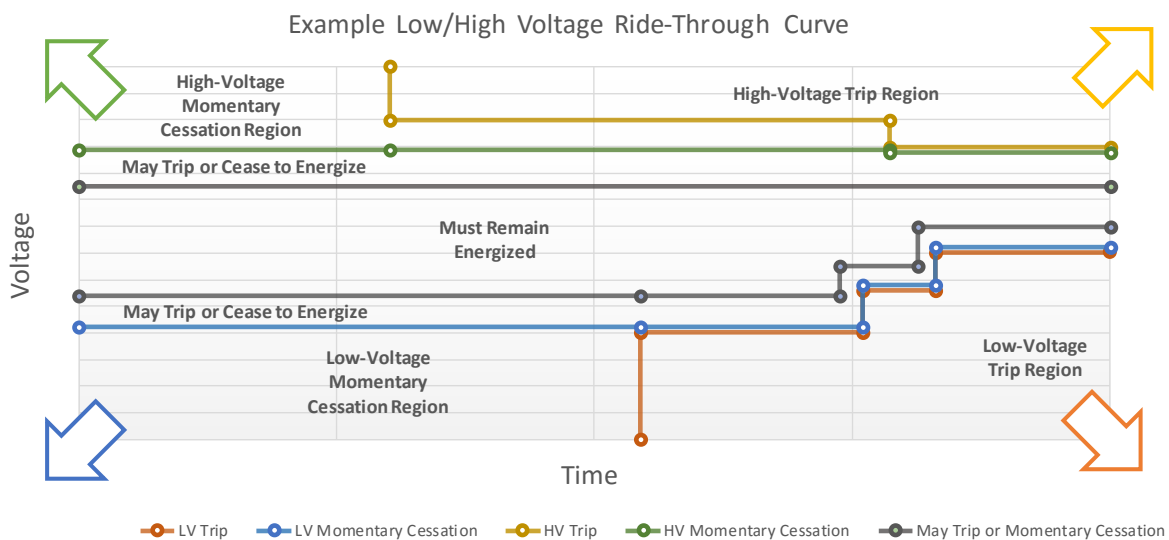

**Figure 16-2**  
**Example low/high voltage ride-through curve**

It should be noted that the arrays and regions are assumed to extend both vertically and horizontally forever. In the example array above a point was defined on the trip curves at 100 seconds and on voltage at 1.4 per-unit. In implementation these arrays should extend forever. An example, in Figure 16-2 if an inverter observes grid voltage of 0.8 per-unit for 160 seconds it would be expected to be in a tripped state. Another example, if an inverter observes grid voltage of 1.6 per-unit for less than 0.1 seconds it would be expected to be in momentary cessation.

It is recognized that most DER will have significant limitations on the shape of the curves that can be supported. Many DER may only be able to support curves with vertical and horizontal curve segments within very specific ranges.

### ***Interpreting the Voltage-Time Curves***

It is recognized that the boundaries created by curves such as that illustrated in Figure 16-1 require explanation in order to be consistently interpreted. In particular, certain voltage vs. time waveforms may be drawn in which the voltage rises and falls, potentially nearing or crossing over the set-boundaries one or more times, and it may not be evident how the DER is expected to respond. For example, what if the voltage drops below the curve, but then rises again to a higher level, then falls again below the curve?

Likewise, testing to determine conformance to a certain curve shape could be conducted in a number of ways, including simple square-pulse testing (step from nominal to a fixed amplitude for a fixed duration), or searching for boundaries, then stepping across for a given duration. The difference between such curve meanings and test methods could have a significant impact on inverter design.

The role of this document is only to provide a mechanism for the transfer of the data, and to do this in a way that is flexible enough to serve the wide range of needs that exist worldwide. It is the domain of grid-codes, interconnect standards, and compliance test specifications to define:

- Required LVRT / HVRT curve settings
- Ranges of configurability
- How curves are intended to be interpreted
- How testing will be carried out

The specific techniques by which smart inverters may filter, average, or otherwise respond to time-varying voltages are also outside the scope of this communication specification. This is left to the manufacturer to determine, in accordance with the grid-codes and tests for which the product is intended to comply.

### ***Defining Voltage in Three Phase Systems***

This communication document does not specify how three phase systems are to interpret L/HVRT settings relative to the three voltages they may measure. It is recognized that many scenarios exist, including the use of the highest of the three, the lowest of the three, or some combination or average. However, it is considered to be the purview of other codes and standards, such as those that may be produced by the IEEE, national governments, or other entities to define how L/HVRT settings are to be interpreted by poly-phase systems.

### ***Pre-Clearing Behavior During Voltage Events***

During high or low voltage events, before disconnecting (clearing) occurs, it is intended that devices will continue to operate, delivering (or receiving in the case of storage devices) power to the grid to the best of their ability. Note that this L/HVRT function is accompanied by a “Dynamic VAR Support” function (documented separately) which, if used, may result in VAR support during low and high voltage events, in addition to continuance of Watt production as possible. It is acknowledged that solar and other variable sources are not predictable. It is also

acknowledged that inverters have current limits, VA limits, or thermal limits that may prevent full power output at reduced or elevated voltage levels. Reductions in output in this regard are considered normal and acceptable, as long as devices continue to support the grid with real and reactive power as possible.

It is also recognized that this L/HVRT function may work in conjunction with the Dynamic Volt-Var Function, which is noted below and documented separately.

**Defining Parameters for Reconnect Behavior**

The settings defined above are intended to affect only the disconnect behavior of the DER. Reconnecting may be managed by the parameters listed in Table 16-2 and illustrated in Figure 16-3. This illustration shows all three timing control parameters being used together, although each is optional. Grid codes could require none or any combination of the three.

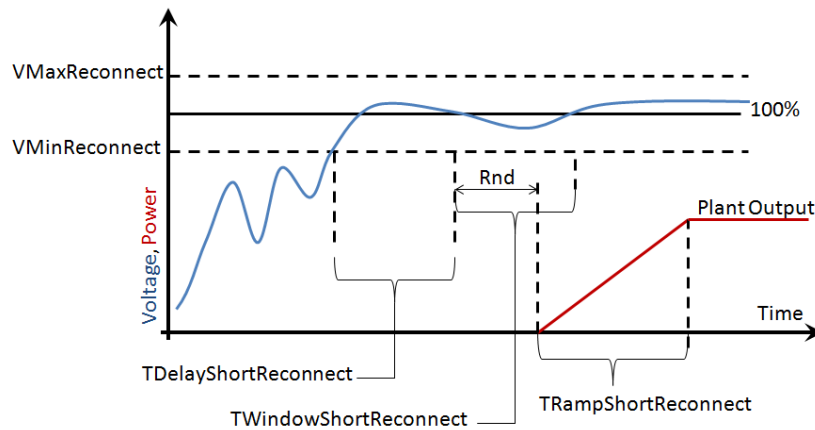

**Figure 16-3**  
Voltage event reconnect example, showing the use of all three optional parameters

**Table 16-2**  
Voltage event reconnect parameters

Name	Description
VMaxReconnect	The maximum level of the service voltage before reconnecting may occur. In other words, the service voltage must be below this level before the DER may reconnect.
VMinReconnect	The minimum level of the service voltage before reconnecting may occur. In other words, the service voltage must be above this level before the DER may reconnect.
TInterruptLimit	The maximum duration of what may be considered a short-term interruption. Is also equal to the minimum duration of what may be considered a long-term interruption.
<b>Short-Term Disturbance</b>	

Name	Description
TDelayShortReconnect	<p>Following a short-term disturbance, the minimum time delay before reconnection may occur, after the system voltage and frequency are within the reconnect ranges established by:</p> <ul style="list-style-type: none"> <li>• FMaxReconnect (defined in the L/HFRT Function)</li> <li>• FMinReconnect (defined in the L/HFRT Function)</li> <li>• VMaxReconnect (defined above)</li> <li>• VMinReconnect (defined above)</li> </ul> <p>Note: Use of this parameter is optional. For example, it may be set to zero such that there is no fixed delay period.</p>
TWindowShortReconnect	<p>A randomization window, after TDelayShortReconnect that is applied before reconnection occurs. In other words, after the service voltage is between VMaxReconnect and VMinReconnect, the DER will wait TDelayShortReconnect + Rnd (TWindowShort Reconnect) before reconnecting.</p> <p>Note: Use of this parameter is optional. For example, it may be set to zero such that there is no randomization window.</p>
TRampShortReconnect	<p>A time over which the inverter output (both real and reactive power) will linearly ramp back to full output after reconnecting. (See Figure 16-2)</p> <p>Note: Use of this parameter is optional. For example, it may be set to zero such that there is no ramp time.</p>
TRampShortReconnect_Cha	<p>A time over which the inverter input (both real and reactive power) will linearly ramp back to full input after reconnecting. (See Figure 16-2)</p> <p>Note: Use of this parameter is optional. For example, it may be set to zero such that there is no ramp time. Only used for energy storage systems.</p>
<b>Large-Term Disturbance</b>	
TDelayLongReconnect	<p>Following a long-term disturbance, the minimum time delay before reconnection may occur, after the system voltage and frequency are within the reconnect ranges established by:</p> <ul style="list-style-type: none"> <li>• FMaxReconnect (defined in the L/HFRT Function)</li> <li>• FMinReconnect (defined in the L/HFRT Function)</li> <li>• VMaxReconnect (defined above)</li> <li>• VMinReconnect (defined above)</li> </ul> <p>Note: Use of this parameter is optional. For example, it may be set to zero such that there is no fixed delay period.</p>
TWindowLongReconnect	<p>A randomization window, after TDelayLongReconnect that is applied before reconnection occurs. In other words, after the service voltage is between VMaxReconnect and VMinReconnect, the DER will wait TDelayLongReconnect + Rnd(TWindowLongReconnect) before reconnecting.</p> <p>Note: Use of this parameter is optional. For example, it may be set to zero such that there is no randomization window.</p>
TRampLongDisconnect	<p>A time over which the inverter output (both real and reactive power) will linearly ramp back to full output after reconnecting. (See Figure 16-2)</p> <p>Note: Use of this parameter is optional. For example, it may be set to zero such that there is no ramp time.</p>

Name	Description
TRampLongDisconnect_Cha	<p>A time over which the inverter input (both real and reactive power) will linearly ramp back to full input after reconnecting.</p> <p>Note: Use of this parameter is optional. For example, it may be set to zero such that there is no ramp time. Only used for energy storage systems.</p>

### ***VAR Support During High and Low Voltage Events***

As noted in the section above on “Pre-Clearing Behavior”, these L/HVRT functions define only the connect/disconnect behavior relative to voltage deviations. VAR support during these deviations is also possible, by using the Volt-Var Function and the Dynamic Reactive Current Support Function defined elsewhere in this specification. The dynamic reactive current support function provides configuration and management to allow additional reactive current support during transient voltage events. Such support may provide grid benefits beyond what is possible with real power support alone.

# 17

## LOW/HIGH FREQUENCY RIDE-THROUGH FUNCTION

### Scope of This Function

This proposal is for the Phase 3 Smart Inverter Communication Project, for a Low/High Frequency Ride-Through function. This initiative is describing a toolkit of functions that are being defined using a standardized information model which can then be mapped into a variety of protocols.

None of the functions being described through this initiative are necessarily “mandatory” from an implementation perspective – actually requiring certain functions to be implemented is the purview of regulators and of the purchasers of systems. The works into which this function will be added state that “if a function is to be implemented, then it must be implemented according to these specifications”.

This specification is intended to provide a flexible mechanism through which general Low/High Frequency Ride-Through (L/HFRT) behavior may be configured, if so desired. In this context, L/HFRT refers only to the connect/disconnect behavior of the distributed energy resource (DER), essentially defining the frequency conditions under which the DER may and must connect and disconnect.

This function defines only the mechanism through which the L/HFRT settings may be made and does NOT define the settings that would be used. Various countries, states, utilities, or other organizations such as the IEEE may issue specific L/HFRT setting requirements or recommendations. The intention is that this function will be sufficiently flexible to support all such requirements.

### Requirements/Use Cases

The context for the inclusion of this function in this Phase 2 project was the identification of the need to consider such a function in ongoing IEEE 1547 meetings, as well as California Rule 21 update discussions and FERC rules.

Specifically, the following needs were represented:

- High Penetration Circumstances. Utilities have stated that existing IEEE 1547 rules are suitable for low penetration circumstances but that different L/HFRT settings may be needed for higher penetration circumstances. When the reliable delivery of power to loads becomes dependent on the generation of distributed resources, then fast disconnection during frequency disturbances may not be desirable. Rather, utilities need flexibility in configuring the behavior of devices under these circumstances.
- Islanding. In scenarios where islanding can occur ride-through requirements may be modified to suit the variability and stability of islanded grids.

### Prior Bodies of Work

None.

## **L/HFRT Proposal**

The difference in how parameters for L/HV*oltage*RT and L/HF*requency*RT are minor. The main difference is frequency disturbance response standards do not include momentary cessation regions so only the trip curve is required. This is due to power system reliability requirements. The majority of this capture is a clone of the L/VHRT Parameters function except for this exception.

This proposal provides a mechanism by which a wide range of settings may be passed to/from a smart inverter via a communication system in order to manage Low/High Frequency Ride-Through (L/HFRT) behavior. These settings represent the superset of needs that are presently known or anticipated. It is recognized that for many situations, the full capabilities supported herein may not be required and that, as a result, certain settings may not be used or required.

Trip and momentary cessation curves can be represented as piece-wise linear curves that define the regions associated with frequency trip behavior. It is desirable to use a mechanism to represent the curves that is flexible and handles as many use cases as possible. For instance, the curves in European standards require “diagonal” lines that cannot be represented with rectangular regions.

The performance within each region is defined by grid code however the methods to communicate these regions to inverters is not. It is proposed to implement this function using configurable arrays as with prior functions from this initiative’s work. The arrays of X-Y points allow the user to define a piece-wise linear “curve” which defines the desired behavior or operating bounds. For L/HFRT, it is proposed that two curves may be defined, creating three regions (above and below the 100% line), as illustrated in Figure 17-1, including:

- High Frequency Must Trip
- May Trip or Cease to Energize
- Low Frequency Must Trip

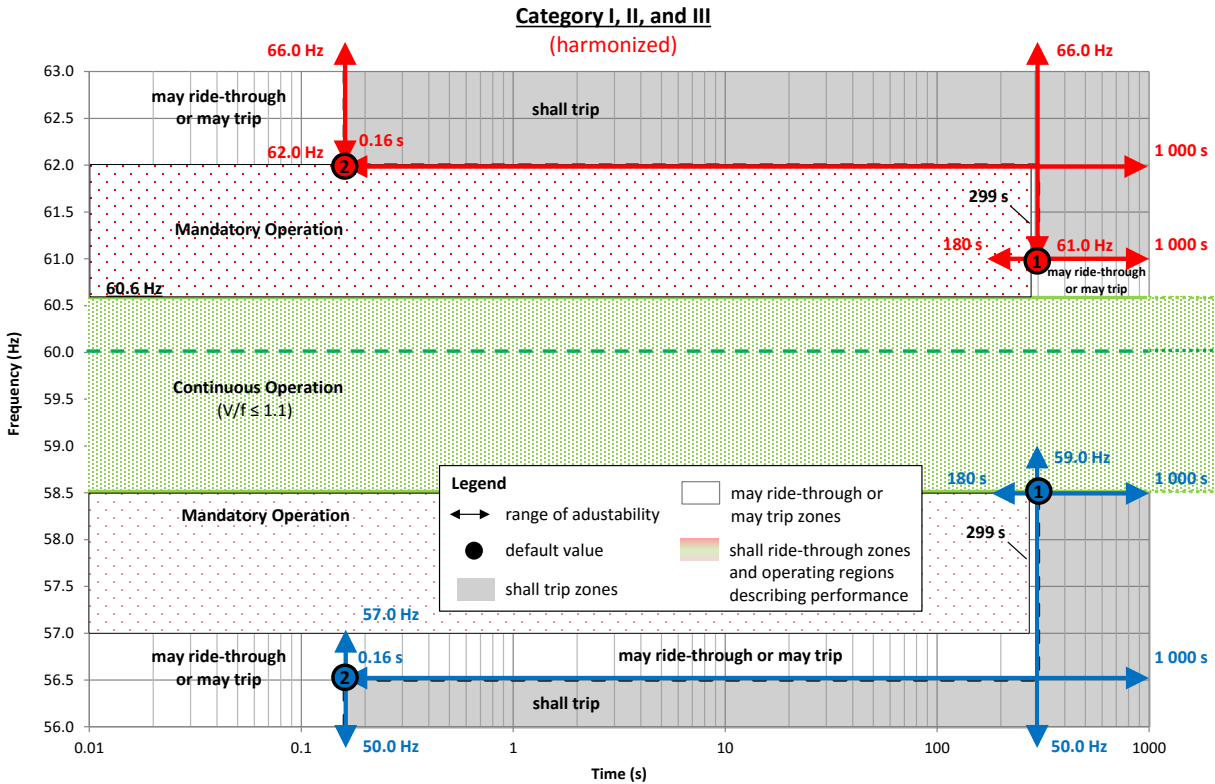

**Figure 17-1**  
**The example of the different zones.<sup>5</sup>**

Each curve can be defined using an array. An example is provided in Table 17-1 for the low and high frequency trip values. The arrays can be interpreted using two similar approaches.

**Table 17-1**  
**Example array for L/HFRT array**

Curve	Points
Low-Frequency Trip	(0, 56), (0, 56.6), (56.6, 180), (58.8, 180), (58.5, 100)
High-Frequency Trip	(0.63), (0, 63), (180, 62), (180, 61), (1000, 61)

The two arrays create three regions. Depending on what the inverter has observed on the grid it falls in one of the regions. If the inverter falls into the trip region it must trip offline.

<sup>5</sup> J.C. Boemer et al., “Status of Revision of IEEE Std 1547 and 1547.1: Informal report based on IEEE P1547/Draft 5.0 (August 2016).” Paper presented at the 6th International Workshop on Integration of Solar Power into Power Systems, Vienna, Austria, November 14-15, 2016 [Online] [http://integratedgrid.com/wp-content/uploads/2016/10/EPRI\\_IEEE-P1547-and-P1547.1-Overview-August-2016\\_v2.pdf](http://integratedgrid.com/wp-content/uploads/2016/10/EPRI_IEEE-P1547-and-P1547.1-Overview-August-2016_v2.pdf).

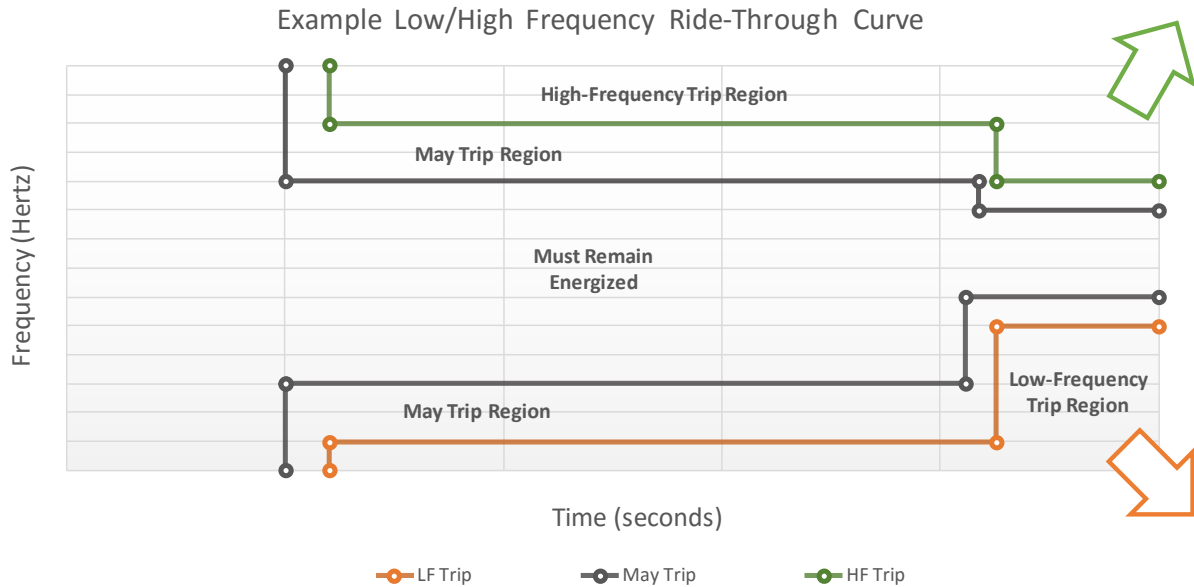

**Figure 17-2**  
**Example low/high voltage ride-through curve**

It should be noted that the arrays and regions are assumed to extend both vertically and horizontally forever. An example, in Figure 17-2 if an inverter observes grid frequency of 57 hertz for 1,005 seconds it would be expected to be in a tripped state. Another example, if an inverter observes grid frequency of 62.5 hertz for less than 0.1 seconds it would be expected to be tripped.

It is recognized that most DER will have significant limitations on the shape of the curves that can be supported. Many DER may only be able to support curves with vertical and horizontal curve segments within very specific ranges.

### ***Interpreting the Frequency-Time Curves***

As with prior industry discussions regarding VRT functionality, it was recognized that the boundaries created by curves such as that illustrated in Figure 17-1 require explanation in order to be consistently interpreted. In particular, certain frequency vs. time waveforms may be drawn in which the frequency rises and falls, potentially nearing or crossing over the set-boundaries one or more times, and it may not be evident how the DER is expected to respond. For example, what if the frequency drops below the curve, but then rises again to a higher level, then falls again below the curve?

Likewise, testing to determine conformance to a certain curve shape could be conducted in a number of ways, including simple square-pulse testing (step from nominal to a fixed amplitude for a fixed duration), or searching for boundaries, then stepping across for a given duration. The difference between such curve meanings and test methods could have a significant impact on inverter design.

The role of this document is only to provide a mechanism for the transfer of the data, and to do this in a way that is flexible enough to serve the wide range of needs that exist worldwide. It is the domain of grid-codes, interconnect standards, and compliance test specifications to define:

- Required LFRT / HFRT curve settings
- Ranges of configurability
- How curves are intended to be interpreted
- How testing will be carried out

The specific techniques by which smart inverters may filter, average, or otherwise respond to time-varying frequencies are also outside the scope of this communication specification. This is left to the manufacturer to determine, in accordance with the grid-codes and tests for which the product is intended to comply.

### ***Pre-Clearing Behavior During Frequency Events***

During high or low frequency events, before disconnecting (clearing) occurs, it is intended that devices will continue to operate, delivering (or receiving in the case of storage devices) real power and reactive power to the grid according to their configuration and to the best of their ability. Note that this L/HFRT function is accompanied by a “Frequency-Watt” function (documented separately) which, if used, may result in additional Watt support during low and high frequency events. It is acknowledged that solar and other variable sources are not predictable. It is also acknowledged that inverters and coupling transformers may have current limits, VA limits, or thermal limits that may prevent full power output at reduced or elevated frequency levels. Reductions in output in this regard are considered normal and acceptable, as long as devices continue to support the grid with real and reactive power as possible.

### ***Defining Parameters for Reconnect Behavior***

The settings defined above are intended to affect only the disconnect behavior of the DER. Reconnecting may be managed by the parameters listed in Table 17-1 and Table 17-2 and illustrated in Figure 17-2. This illustration shows all three timing control parameters being used together, although each is optional. Grid codes could require none or any combination of the three.

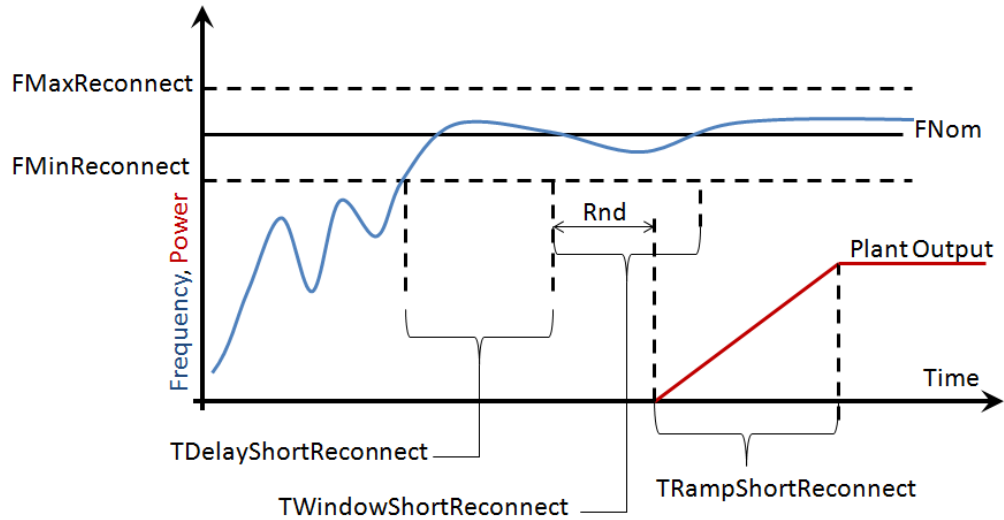

**Figure 17-3,**  
**Frequency event reconnection example, showing the use of all three optional parameters**

**Table 17-2**  
**Additional reconnect parameters involving frequency**

Name	Description
FMaxReconnect	The maximum level of the system frequency before reconnecting may occur. In other words, the system frequency must be below this level before the DER may reconnect.
FMinReconnect	The minimum level of the system frequency before reconnecting may occur. In other words, the system frequency must be above this level before the DER may reconnect.

In addition to these two frequency-specific settings, the reconnect behavior is further managed by the time-related parameters shown in Table 17-2 that are already defined in the L/HFRT Function:

**Table 17-3**  
**Related parameters already defined in the L/HVRT function**

Name	Description
TInterruptLimit	The maximum duration of what may be considered a short-term disturbance. Is also equal to the minimum duration of what may be considered a long-term disturbance.
<b>Short-Term Disturbance</b>	
TDelayShortReconnect	<p>Following a short-term disturbance, the minimum time delay before reconnection may occur, after the system voltage and frequency are within the reconnect ranges established by:</p> <ul style="list-style-type: none"> <li>• FMaxReconnect (defined above)</li> <li>• FMinReconnect (defined above)</li> <li>• VMaxReconnect (defined in the L/HVRT Function)</li> <li>• VMinReconnect (defined in the L/HVRT Function)</li> </ul> <p>Note: Use of this parameter is optional. For example, it may be set to zero such that there is no fixed delay period.</p>
TWindowShortReconnect	<p>A randomization window, after TDelayShortReconnect that is applied before reconnection occurs. In other words, after the system voltage and frequency are within the reconnect ranges identified above, the DER will wait TDelayShortReconnect + Rnd(TWindowShortReconnect) before reconnecting.</p> <p>Note: Use of this parameter is optional. For example, it may be set to zero such that there is no randomization window.</p>
TRampShortReconnect	<p>A time over which the inverter output (both real and reactive power) will linearly ramp back to full output after reconnecting. (See Figure 17-3)</p> <p>Note: Use of this parameter is optional. For example, it may be set to zero such that there is no ramp time.</p>
TRampShortReconnect_Cha	<p>A time over which the inverter input (both real and reactive power) will linearly ramp back to full input after reconnecting. (See Figure 17-2)</p> <p>Note: Use of this parameter is optional. For example, it may be set to zero such that there is no ramp time. Only used for energy storage systems.</p>
<b>Large-Term Disturbance</b>	
TDelayLongReconnect	<p>Following a long-term disturbance, the minimum time delay before reconnection may occur, after the system voltage and frequency are within the reconnect ranges established by:</p> <ul style="list-style-type: none"> <li>• FMaxReconnect (defined above)</li> <li>• FMinReconnect (defined above)</li> <li>• VMaxReconnect (defined in the L/HVRT Function)</li> <li>• VMinReconnect (defined in the L/HVRT Function)</li> </ul> <p>Note: Use of this parameter is optional. For example, it may be set to zero such that there is no fixed delay period.</p>

Name	Description
TWindowLongReconnect	<p>A randomization window, after TDelayLongReconnect that is applied before reconnection occurs. In other words, after the system voltage and frequency are within the reconnect ranges identified above, the DER will wait TDelayLongReconnect + Rnd(TWindowLongReconnect) before reconnecting.</p> <p>Note: Use of this parameter is optional. For example, it may be set to zero such that there is no randomization window.</p>
TRampLongReconnect	<p>A time over which the inverter output (both real and reactive power) will linearly ramp back to full output after reconnecting.</p> <p>Note: Use of this parameter is optional. For example, it may be set to zero such that there is no ramp time.</p>
TRampLongReconnect_Cha	<p>A time over which the inverter input (both real and reactive power) will linearly ramp back to full input after reconnecting.</p> <p>Note: Use of this parameter is optional. For example, it may be set to zero such that there is no ramp time. Only used for energy storage systems.</p>

***Special Watt Behaviors During High and Low Frequency Events***

As noted in the section above on “Pre Clearing Behavior”, these L/HFRT functions define only the connect/disconnect behavior relative to frequency deviations. Special Watt support during these deviations is also possible, by using the Frequency-Watt Function defined elsewhere in this specification.

# 18

## DYNAMIC REACTIVE-CURRENT SUPPORT FUNCTION

### Scope

This proposal is for the Phase 2 Smart Inverter Communication Project, for a Dynamic Reactive Current Function (an extension to agenda item 3). This initiative is defining a toolkit of functions that are being defined using a standardized model which can then be mapped into a variety of protocols.

This specification is intended to provide a flexible mechanism through which inverters may be configured to provide reactive current support in response to dynamic variations in voltage. This function is distinct from the existing steady-state Volt-Var function in that the controlling parameter is the change in voltage rather than the voltage level itself. In other words, the power system voltage may be above normal, resulting in a general need for inductive Vars, but if it is also falling rapidly, this function could produce capacitive reactive current to help counteract the dropping of the voltage.

### Requirements/Use Cases

This is a type of dynamic system stabilization function. Such functions create an effect that is in some ways similar to momentum or inertia, in that it resists rapid change in the controlling parameter. Two use cases can be distinguished:

1. Power quality in the distribution system, such as flicker, may be improved by the implementation of functions of this type and when implemented in fast-responding solid-state inverters, these functions may provide other (slower) grid equipment with time to respond.
2. With the objective of improving bulk power system stability, fault-induced delayed voltage recovery (FIDVR) caused by single-phase induction motors used in many air conditioning systems may be addressed by the implementation of functions of this type. Depending on the time performance of this function, stalling of these motors may be prevented overall or only the voltage recovery in the post-fault period may be improved. Functions of this type may also be able to keep other devices during and following voltage disturbances online, including loads and “legacy” DER that do not have L/HVRT.

### Prior Bodies of Work

The initial contribution to this function has come from the German grid codes as presented to IEC TC57, WG17. This group has been working to codify certain advanced inverter functions. This IEC work, when completed, will be documented as 61850-90-7 (not publicly available at the time of this writing).

## Proposal

It is proposed to provide support for a behavior as illustrated in Figure 18-1. This function provides dynamic reactive current support in response to a sudden rise or fall in the voltage at the Point of Common Coupling (PCC).

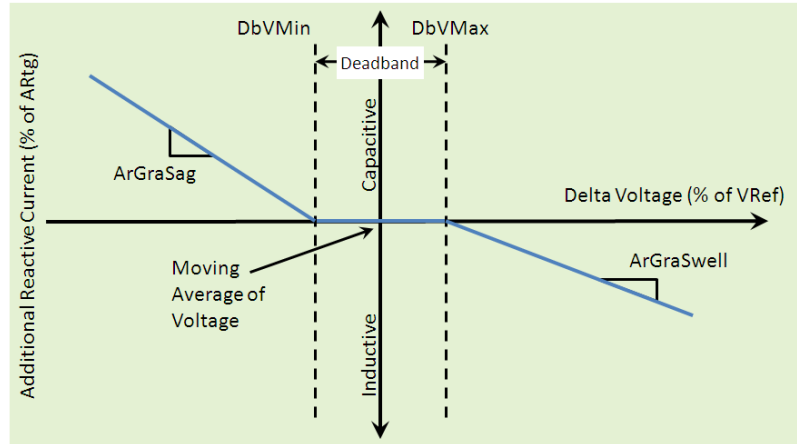
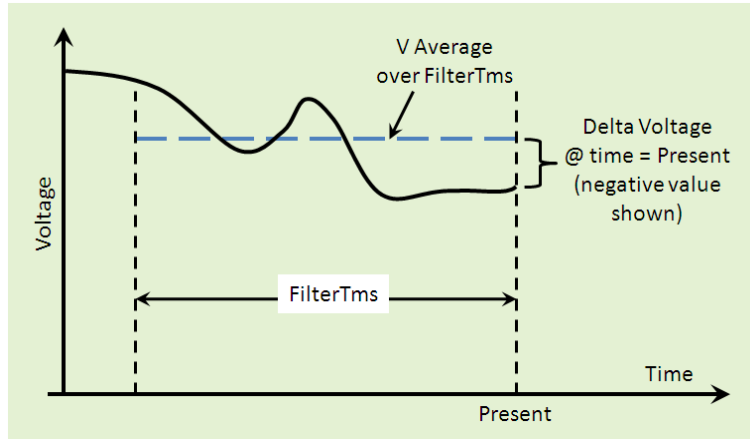

**Figure 18-1**  
**Dynamic reactive current support function, basic concept**

This function identifies “Delta Voltage” as the difference between the present voltage and the moving average of voltage, **VAverage** (a sliding linear calculation), over a preceding window of time specified by **FilterTms**. The calculation of Delta Voltage (**Delta Voltage = Present Voltage – Moving Average Voltage**, expressed as a percentage of **VRef**) is illustrated at time = “Present” in Figure 18-2.

The “present voltage” in this context refers to the present **ACRMS** voltage, which requires a certain period to calculate. For example, some inverters might recompute voltage every half-cycle of the AC waveform. It is outside the scope of this specification to define the method or timing of the **ACRMS** measurement.

Parameters **DbVMin** and **DbVMax** allow the optional creation of a dead band inside which zero dynamic current is generated. The separate **ArGraSag** and **ArGraSwell** parameters make it possible to independently define the rate that the magnitude of additional reactive current increases as delta-voltage increases or decreases, as illustrated.



**Figure 18-2**  
Delta-voltage calculation

### ***Event-Based Behavior***

This function includes an option to manage how the dynamic reactive current support function is managed, as indicated in Figure 18-3 and described below.

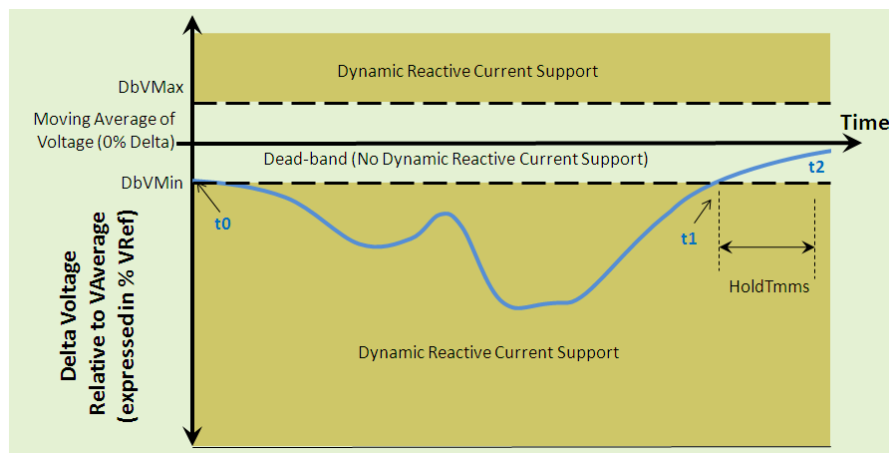

**Figure 18-3**  
Activation zones for reactive current support

Activation of this behavior allows for a voltage sag or swell to be thought of as an “event”. The event begins when the present voltage moves above the moving average voltage by **DbVMax** or below by **DbVMin**, as shown by the blue line in Figure 18-3 and labeled as **t0**.

In the example shown, reactive current support continues until a time **HoldTms** after the voltage returns above **DbVMin** as shown. In this example, this occurs at time **t1**, and this event continues to be considered active until time **t2** (which is **t1 + HoldTms**).

When this behavior is activated, the moving average voltage (**VAverage**) and any reactive current levels that might exist due to other functions (such as the static Volt-VAR function) are frozen at **t0** when the “event” begins and are not free to change again until **t2** when the event ends. The reactive current level specified by this function (Figure 18-1 or Figure 18-4) continues to vary throughout the event and be added to any frozen reactive current.

## Alternative Gradient Shape

This function includes the option of an alternative behavior to that shown in Figure 18-1. **ArGraMod** selects between the behavior of Figure 18-1 (gradients trend toward zero at the deadband edges) and that of Figure 18-4 (gradients trend toward zero at the center). In this alternative mode of behavior, the additional reactive current support begins with a step change when the “event” begins (at **DbVMin** for example), but then follows a gradient through the center until the event expires, **HoldTmms** after the voltage returns above the **DbVMin** level.

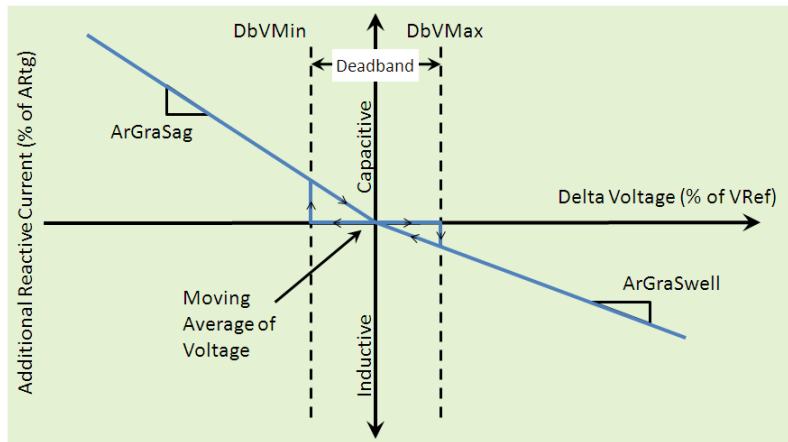
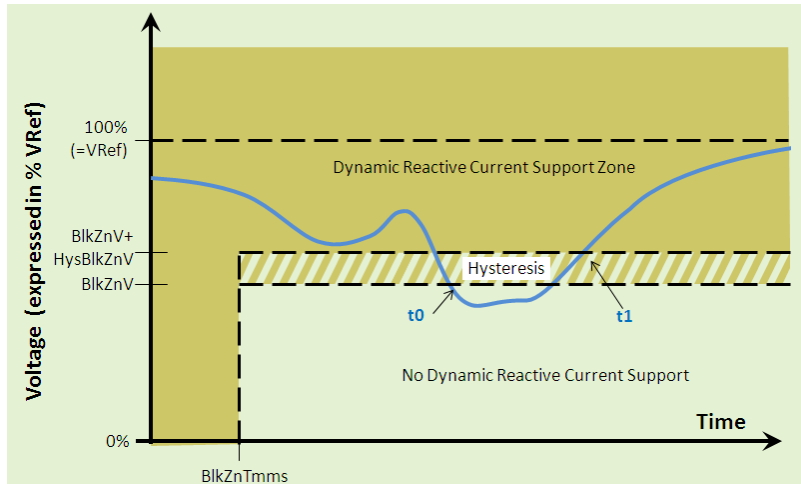

**Figure 18-4**  
Alternative gradient behavior, selected by **ArGraMod**

## Blocking Zones

This function also allows for the optional definition of a blocking zone, inside which additional reactive current support is not provided. This zone is defined by the three parameters **BlkZnTmms**, **BlkZnV**, and **HysBlkZnV**. It is understood that all inverters will have some self-imposed limit as to the depth and duration of sags which can be supported, but these settings allow for specific values to be set, as required by certain country grid codes.

As illustrated in Figure 18-5, at  $t_0$ , the voltage at the ECP falls to the level indicated by the **BlkZnV** setting and dynamic reactive current support stops. Current support does not resume until the voltage rises above **BlkZnV + HysBlkZnV** as shown at  $t_1$ . **BlkZnTmms** provides a time, in milliseconds, before which dynamic reactive current support continues, regardless of how low voltage may sag. **BlkZnTmms** is measured from the beginning of any sag “event” as described previously.



**Figure 18-5**  
**Settings to define a blocking zone**

***Relationship to the Static Volt-Var Function***

As indicated in Figure 18-1, the reactive current level indicated by this dynamic stabilization function is defined as “additional” Current. This means that it is added to the reactive current that might exist due to a static Volt-Var function or fixed power factor setting that is also currently active.

For example, a static volt-var configuration may involve a curve that, at the present operating voltage, results in Var generation of +1000[Vars]. At the same time, this function may be detecting a rising voltage level, and may be configured to produce a reactive current amounting to -300[Vars] in response. In this case, the total Var output would be +700[Vars].

Units may also be configured so that the Var level indicated by this dynamic Volt-Var function are the only Vars, by not activating other Var controls, such as the static Volt-Var modes or non-unity power factor settings.

***Dynamic Reactive Current Support Priority Relative to Watts***

Under certain operating conditions, the production of the additional reactive current specified by this function could imply a reduction in real-power levels based on the inverter’s limits. Such a reduction may or may not be beneficial in terms of providing optimal dynamic support to the grid.

To handle this possibility, an optional Boolean setting called “DynamicReactiveCurrentMode” is defined, with associated behaviors as identified in Table 18-1. Implementation and utilization of this Boolean is optional. If it is not used or supported, the default behavior is that real power levels (Watts) are curtailed as needed to support this function.

**Table 18-1**  
**Dynamic reactive current mode control**

Setting	Implication	Present Condition	Behavior of this Function
DynamicReactiveCurrentMode = 0	Reactive current is preferred over Watts	Inverter is Delivering Real Power, Voltage Sags	Dynamic reactive current takes priority over Watts

Setting	Implication	Present Condition	Behavior of this Function
(default)	for grid support		
		Inverter is Delivering Real Power, Voltage Swells	Dynamic reactive current takes priority over Watts
		Inverter is Absorbing Real Power, Voltage Sags	Dynamic reactive current takes priority over Watts
		Inverter is Absorbing Real Power, Voltage Swells	Dynamic reactive current takes priority over Watts
DynamicReactive CurrentMode = 1	Watts are preferred over reactive current for grid support	Inverter is Delivering Real Power, Voltage Sags	Watts take priority over dynamic reactive current
		Inverter is Delivering Real Power, Voltage Swells	Dynamic reactive current takes priority over Watts
		Inverter is Absorbing Real Power, Voltage Sags	Dynamic reactive current takes priority over Watts
		Inverter is Absorbing Real Power, Voltage Swells	Watts take priority over dynamic reactive current

### Settings to Manage This Function

As shown in the previous figures, the settings used to configure this function are:

**Table 18-2**  
**Settings for dynamic reactive current function**

Name	Description
Enable/Disable Dynamic Reactive Current Support Function	This is a Boolean that makes the dynamic reactive current support function active or inactive.
DbVMin	This is a voltage deviation relative to $V_{average}$ , expressed in terms of % of $V_{ref}$ (for example -10% $V_{ref}$ ). For negative voltage deviations (voltage below the moving average) that are smaller in amplitude than this amount, no additional dynamic reactive current is produced.
DbVMax	This is a voltage deviation relative to $V_{average}$ , expressed in terms of % of $V_{ref}$ (for example +10% $V_{ref}$ ). For positive voltage deviations (voltage above the moving average) that are smaller in amplitude than this amount, no additional dynamic reactive current is produced. Together, DbVMin and DbVMax allow for the creation of a dead-band, inside of which the system does not generate additional reactive current support.
ArGraSag	This is a gradient, expressed in unit-less terms of %/%, to establish the ratio by which Capacitive % VAR production is increased as %Delta-Voltage decreases below DbVMin. Note that the % Delta-Voltage may be calculated relative to Moving Average of Voltage + DbVMin (as shown in Figure 18-1) or relative to Moving Average of Voltage (as shown in Figure 18-4), according to the ArGraMod setting.
ArGraSwell	This is a gradient, expressed in unit-less terms of %/%, to establish the ratio by which Inductive % Var production is increased as %Delta-Voltage increases above DbVMax. Note that the % Delta-Voltage may be calculated relative to Moving Average of Voltage + DbVMax (as shown in Figure 18-1) or relative to Moving Average of Voltage (as shown in Figure 18-4), according to the ArGraMod setting.
FilterTms	This is the time, expressed in seconds, over which the moving linear average of voltage is calculated to determine the Delta-Voltage.

Name	Description
<b>Additional Settings (Optional)</b>	
ArGraMod	This is a select setting that identifies whether the dynamic reactive current support acts as shown in Figure 18-1 or Figure 18-4. (0 = Undefined, 1 = Basic Behavior (Figure 18-1), 2 = Alternative Behavior (Figure 18-4).
BlkZnV	This setting is a voltage limit, expressed in terms of % of Vref, used to define a lower voltage boundary, below which dynamic reactive current support is not active.
HysBlkZnV	This setting defines a hysteresis added to BlkZnV in order to create a hysteresis range, as shown in Figure 18-5, and is expressed in terms of % of VRef.
BlkZnTmms	This setting defines a time (in milliseconds), before which reactive current support remains active regardless of how deep the voltage sag. As shown in Figure 18-5.
Enable/Disable Event-Based Behavior	This is a Boolean that selects whether or not the event-based behavior is enabled.
Dynamic Reactive Current Mode	This is a Boolean that selects whether or not Watts should be curtailed in order to produce the reactive current required by this function.
HoldTmms	This setting defines a time (in milliseconds) that the delta-voltage must return into or across the dead-band (defined by DbVMin and DbVMax) before the dynamic reactive current support ends, frozen parameters are unfrozen, and a new event can begin.



# 19

## DYNAMIC REAL-POWER SUPPORT

### Scope of This Function

This proposal is for the Phase 2 Smart Inverter Communication Project, for a Real Power Smoothing Function. This function has initially been identified in relation to compensation for intermittent renewables and transient loads.

This specification is intended to provide a flexible mechanism through which inverters, such as those associated with energy storage systems, may be configured to provide a smoothing function for loads or generation. This function involves the dynamic dispatch of energy in order to compensate for variations in the power level a reference signal. With proper configuration, this function may be used to compensate for either variable load or variable generation.

### Requirements/Use Cases

This function was identified as a requirement by several utilities working together in EPRI's storage research program (P94). These utilities have developed a specification for a large scale Lithium Transportable Energy Storage System (Li-TESS) which includes a requirement for a Load/Generation Smoothing function.

### Prior Bodies of Work

None.

### Proposal

This proposal describes a method by which distributed energy resources (DER) may perform a load/generation smoothing function as described in the following subsections.

#### ***Real Power Smoothing***

This function provides settings by which a DER may dynamically absorb or produce additional Watts in response to a rise or fall in the power level of a reference point of load or generation. This function utilizes the same basic concepts and settings as the "Dynamic VAR Support Function" described separately.

The Watt levels indicated by this function are additive – meaning that they are in addition to whatever Watt level the DER might otherwise be producing. The dynamic nature of this function (being driven by the change ( $dW/dt$ ) in load or generation level as opposed to its absolute level makes it well suited for working in conjunction with other functions.

As illustrated in the left pane of Figure 19-1, this function allows the setting of a "Smoothing Gradient" which is a unit-less quantity (Watts produced per Watt-Delta). This is a signed quantity. The example in Figure 19-1 shows a negative slope. A value of -1.0 would absorb one additional Watt (or produce one less Watt) for each Delta Watt (Present Wattage – Moving Average) of the reference device. Negative settings would be a natural fit for smoothing variable

generation, where the DER would dynamically reduce power output (or absorb more) when the reference generation increased.

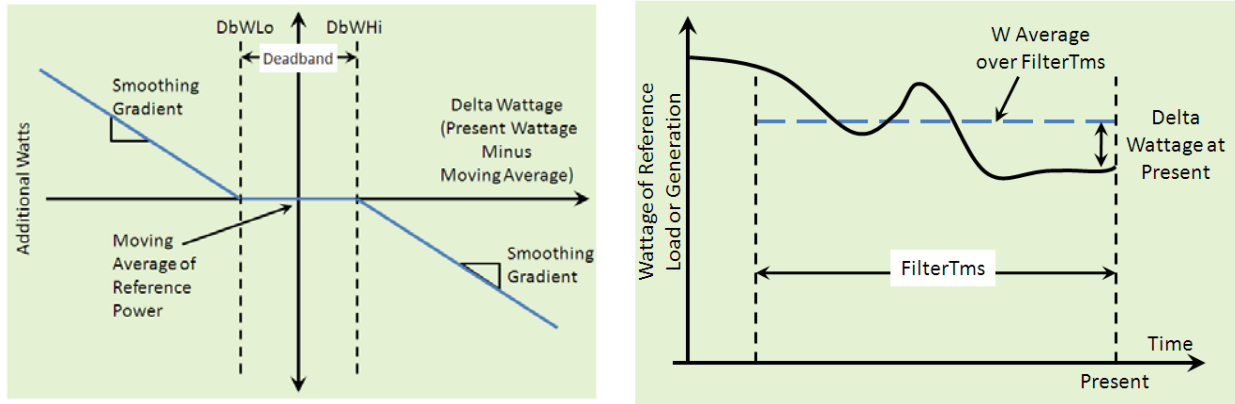

**Figure 19-1**  
**Smoothing function behavior**

Likewise, a gradient setting of +1.0 would generate one additional Watt (or absorb one less Watt) for each Delta Watt (Present Wattage – Moving Average) of the reference device. Positive settings would be a natural fit for smoothing variable load, where the DER would dynamically increase power output (or absorb less) when the reference load increased.

As illustrated in the right frame of Figure 19-1, The Delta Wattage is to be computed as Present Wattage – Moving Average, where the Moving Average is calculated as a sliding linear average over the previous “**FilterTms**” period. **FilterTms** is configurable.

**Limitations of the Function**

As with all functions, DER will operate within self-imposed limits and will protect their own components. These limits are acknowledged to vary, depending on many factors (e.g. state of maintenance, damage, temperature). In addition, it is acknowledged that the load/generation following and real power smoothing functions are limited by present device limit settings, such as WMax.

There are also practical limits to a DER system’s ability to provide load/generation following. For example, an energy storage system cannot follow load or generation indefinitely, and must at some point recharge or discharge in order to continue. Methods to handle this could include scheduling of the load/generation following modes so that regular charge/discharge commands are used at other times.

## Settings to Manage This Function

The following settings are defined to manage this function:

**Table 19-1**  
**Real power smoothing function settings**

Setting Name	Description
Enable/Disable Real Power Smoothing	This is a Boolean that makes the function active or inactive.
Smoothing Gradient	This is a signed quantity that establishes the ratio of smoothing Watts to the present delta-watts of the reference load or generation. Positive values are for following load (increased reference load results in a dynamic increase in DER output), and negative values are for following generation (increased reference generation results in a dynamic decrease in DER output).
FilterTms	This is a configurable setting that establishes the linear averaging time of the reference power (in Seconds).
DbWLo and DbWHi	These are optional settings, in Watts, that allow the creation of a dead-band inside which power smoothing does not occur.
Time Window	This is a window of time over which the inverter randomly delays before beginning execution of the command. For example, an inverter given a new smoothing configuration (or function activation) and a Time-Window of 60 seconds would wait a random time between 0 and 60 seconds before beginning to put the new settings into effect. The purpose of this parameter is to avoid large numbers of devices from simultaneously changing state if addressed in groups.
Ramp Times	<p>This is a fixed time in seconds, over which the inverter settings (Watts in this case) are to transition from their pre-setting level to their post-setting level. The purpose of this parameter is to prevent sudden changes in output as a result of the receipt of a new command or mode activation. Note: this setting does <u>not</u> impact the rate of change of Watt output during run-time as a result of power changes at the reference point.</p> <p>There are four individual ramp times for this function,</p> <ul style="list-style-type: none"> <li>• Ramp Time – Increasing</li> <li>• Ramp Time – Decreasing</li> <li>• Ramp Time_ - Increasing and Charging</li> <li>• Ramp Time – Decreasing and Charging</li> </ul>
Time-Out Window	This is a time after which the setting expires. A value of zero means to never expire. After expiration, the Power Smoothing settings would no longer be in effect.



# 20

## DYNAMIC VOLT-WATT FUNCTION

### Scope of This Function

This proposal is for the Phase 2 Smart Inverter Communication Project, for a Dynamic Volt-Watt Function. This function has initially been identified in relation to compensation for voltage variability that might result from intermittent renewables and other transient loads.

This specification is intended to provide a flexible mechanism through which inverters, such as those associated with energy storage systems, may be configured to dynamically provide a voltage stabilizing function. This function involves the dynamic absorption or production of real power (Watts) in order to resist fast variations in the local voltage at the ECP.

### Requirements/Use Cases

This function was identified as a requirement by several utilities working together in EPRI's storage research program (P94). These utilities have developed a specification for a large scale Lithium Transportable Energy Storage System (Li-TESS) which includes a requirement for a Load/Generation Smoothing function.

### Prior Bodies of Work

None.

### Proposal

This proposal describes a method by which distributed energy resources (DER) may perform a dynamic volt-watt function as described in the following subsections.

This function provides settings by which a DER may dynamically absorb or produce additional Watts in response to a rise or fall in the voltage level at the ECP. This function utilizes the same basic concepts and settings as the "Power Smoothing Function" described separately, except in this case the controlling parameter is the local voltage at the ECP rather than the power level of a remote reference point.

The Watt levels indicated by this function are additive – meaning that they are in addition to whatever Watt level the DER might otherwise be producing. The dynamic nature of this function (being driven by the change ( $dV/dt$ ) in local voltage level as opposed to its absolute level makes it well suited for working in conjunction with other functions.

As illustrated in the left pane of Figure 20-1, this function allows the setting of a "Dynamic Watt Gradient" which determines how aggressively additional Watts are produced relative to the amplitude of voltage deviation. This is a signed, unit-less quantity, expressed as a %/%, or more specifically, as Watts (%WMax) / Volts (%VRef). The example in Figure 20-1 shows a negative slope. A value of -1.0 would absorb one additional %WMax (or produce 1% less) for each 1% VRef increase in Delta Voltage (Present Voltage – Moving Average). Negative settings would be a natural fit for compensating for variable voltages caused by intermittent generation.

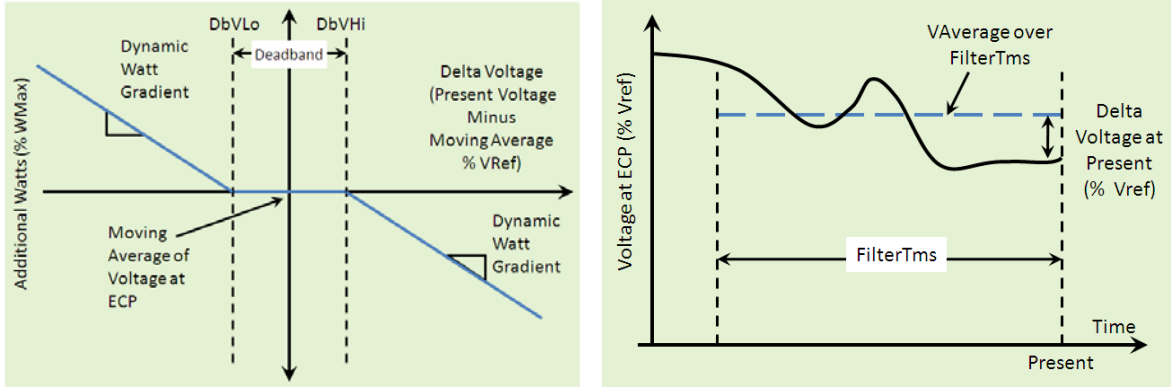

**Figure 20-1**  
**Dynamic volt-watt function behavior**

As illustrated in the right frame of Figure 20-1, The Delta Voltage is to be computed as Present Voltage – Moving Average, and expressed as a percent of VRef, where the Moving Average is calculated as a sliding linear average over the previous “FilterTms” period. **FilterTms** is configurable.

**Limitations of the Function**

As with all functions, DER will operate within self-imposed limits and will protect their own components. These limits are acknowledged to vary, depending on many factors (e.g. state of maintenance, damage, temperature). In addition, it is acknowledged that the dynamic Volt-Watt function is limited by present device limit settings, such as WMax, and physical limitations such as a PV-only system that has no additional Watts to offer.

**Settings to Manage This Function**

The following settings are defined to manage this function:

**Table 20-1**  
**Dynamic volt-watt function settings**

Setting Name	Description
Enable/Disable the Dynamic Volt-Watt Function	This is a Boolean that makes the function active or inactive.
Dynamic Watt Gradient	This is a signed unit-less quantity that establishes the ratio of dynamic Watts (expressed in terms of % WMax) to the present delta-voltage of the reference ECP (expressed as % VRef).
FilterTms	This is a configurable setting that establishes the linear averaging time of the ECP voltage (in Seconds).
DbVLo and DbVHi	These are optional settings, expressed in % VRef, that allow the creation of a dead-band inside which the dynamic volt-watt function does not produce any additional Watts.  For example, setting DbVLo = 10 and DbVHi = 10 results in a dead-band that is 20% of VRef wide.

Setting Name	Description
Time-Out Window	This is a time after which the setting expires. A value of zero means to never expire. After expiration, the Dynamic Volt-Watt settings would no longer be in effect.
Note that this function does not have a “Time Window” or “Ramp Time” parameter because the nature of the function starts out with no action upon activation.	



# 21

## PEAK POWER LIMITING FUNCTION

### Scope of this Function

This proposal is for the Phase 2 Smart Inverter Communication Project, for a Peak Power Limiting Function.

None of the functions being described through this initiative are necessarily “mandatory” from an implementation perspective – actually requiring certain functions to be implemented is the purview of regulators and of the purchasers of systems. The works into which this function will be added state that “if a function is to be implemented, then it should be implemented according to these specifications”.

This specification is intended to provide a flexible mechanism through which inverters, such as those associated with energy storage systems, may be configured to provide a peak-power limiting function. This function involves the variable dispatch of energy in order to prevent the power level at some point of reference from exceeding a given threshold.

### Requirements/Use Cases

Several energy storage system use cases have identified the requirement for this capability. For example:

- Work in the NIST PAP 07 identifies the need for peak power limiting as a use of storage systems.
- DTE Energy has developed a use case for a distributed energy storage system that identifies this function. This use case involves large-scale energy storage units that are strategically placed on distribution systems and designed to limit the power load on particular distribution system assets such as transformers. Such placement could be used to extend the useful life of products, or to defer investments in equipment upgrades.
- San Diego Gas and Electric identifies this function as a use for small pad-mount energy storage systems.
- The Li-TESS storage system specification being developed in EPRI’s Program 94 Storage research requires such a function.

### Prior Bodies of Work

The initial contribution to this function has been developed from the requirements of the SDG&E pad-mount energy storage unit and the generic specification for a transportable energy storage system developed by EPRI’s storage program.

### Proposal

This proposal describes a method by which distributed energy resources (DER) may perform peak load limiting, as illustrated in Figure 21-1.

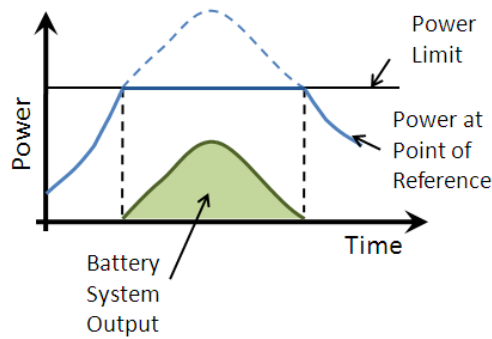

**Figure 21-1**  
**Example peak power limiting waveform**

In this illustration, the solid blue line represents the power measurement at the selected point of reference for the function. As discussed below, this point could be physically located anywhere. Without support from the peak-power limiting function, this hypothetical power measurement would have followed the blue dashed line.

The horizontal black line represents a peak-power limit setting established at the DER by the utility or other asset owner.

The green shaded area represents the power output of the DER. This output follows the part of the blue curve that would have been above the desired power limit. The result is that the power level at the point of reference is limited to (or near to) the power limit setting.

***Limitations of the Function***

As with all functions, DER will operate within self-imposed limits and will protect their own components. These limits are acknowledged to vary, depending on many factors (e.g. state of maintenance, damage, temperature). In addition, it is acknowledged that the peak-limiting function is limited by present device limit settings, such as WMax.

There are also practical limits to a DER system’s ability to provide peak-power limiting. Two common examples are the limitation of the power level that the DER can produce and the limitation on the total energy stored. As illustrated in Figure 21-2, these could result in failure to hold the power level at the reference point to the desired limit for the desired duration.

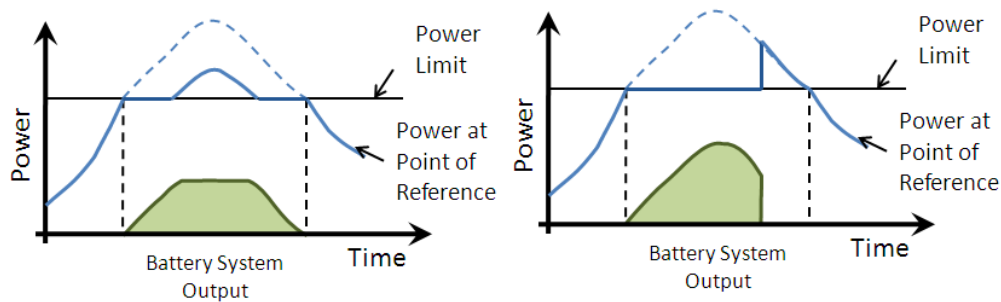

**Figure 21-2**  
**Examples of practical limitations – watt limit (left) and energy storage capacity limit (right)**

### ***Point of Reference for Power Limiting***

Several possibilities might exist for how a DER unit might receive the measurement data indicative of the power flow at the point of reference for the peak power limiting function. Figure 21-3 illustrates two such possibilities.

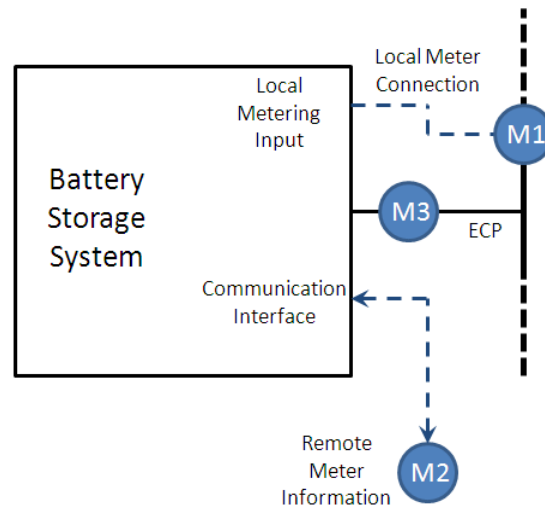

**Figure 21-3**  
**Example points of reference for power limiting**

In this illustration, measurement M1 represents the option of an internal or local measurement that is connected to the DER unit via a local port or analog connection of some kind. M2 represents a remote measurement that could be a great distance from the DER, and providing readings via a communication interface (could be the same interface through which the DER is connected to the utility or another interface). Note that both M1 and M2 indicate the total power flow somewhere on the utility system, not the power flow of the DER itself. This function assumes that increases in the power output of the DER (M3) serve to decrease the power flow at the point of reference (M1 or M2).

It is outside the scope of this specification to dictate to the DER how the measurement data from the point of reference is to be acquired. The idea is that when a peak-power limiting function is supported and enabled, the manufacturer will have built into the product the knowledge of the proper source for the reference data and the user will have set-up and configured the product properly. Examples include:

- A product might include a local measurement that is used for peak limiting.
- A product might use a local communication port to interface with a nearby reference measurement for peak limiting.
- A product might use a local analog input to represent the reference measurement.
- A product might be designed to receive (pulled or pushed) reference measurement from a remote system via the standard communication interface.

### ***Settings to Manage This Function***

The following settings are defined to manage this function:

**Table 21-1**  
**Peak power limiting function settings**

Setting Name	Description
Enable/Disable Peak Power Limit Mode	This is a Boolean that makes the peak power limiting mode active or inactive.
Peak Power Limit	This is the target power level limit, expressed in Watts.
Reference Point Power Level	This is the power measurement in Watts which the DER is using as the reference for peak power limiting. From the perspective of this function, this quantity is read-only. As discussed previously, it is the responsibility of the DER manufacturer and user to configure and establish how the DER acquires this measurement.
Time Window	This is a window of time over which the inverter randomly delays before beginning execution of the command. For example, an inverter given a new Peak Power Limit configuration and a Time-Window of 60 seconds would wait a random time between 0 and 60 seconds before beginning to put the new settings into effect. The purpose of this parameter is to avoid large numbers of devices from simultaneously changing state if addressed in groups.
Ramp Times	<p>This is a fixed time in seconds, over which the inverter settings (Watts in this case) are to transition from their pre-setting level to their post-setting level. The purpose of this parameter is to prevent sudden changes in output as a result of the receipt of a new command. Note: this setting does not impact the rate of change of Watt output during run-time as a result of power changes at the reference point.</p> <p>There are four individual ramp times for this function,</p> <ul style="list-style-type: none"> <li>• Ramp Time – Increasing</li> <li>• Ramp Time – Decreasing</li> <li>• Ramp Time_ - Increasing and Charging</li> <li>• Ramp Time – Decreasing and Charging</li> </ul>
Time-Out Window	This is a time after which the setting expires. A value of zero means to never expire. After expiration, the Peak-Power Limit settings would no longer be in effect.

***Difference between “Peak Power Limiting” and “Load And Generation Following Function”***

The “Peak Power Limiting” and “Load And Generation Following Function” are similar and often confused. “Load following” doesn’t include the effect of the inverter at the metering location while “Peak power limiting” does include the effect of the inverter at the metering location. This is an important distinction from a controls implementation perspective. Those implementing or applying these functions should consider the following two points.

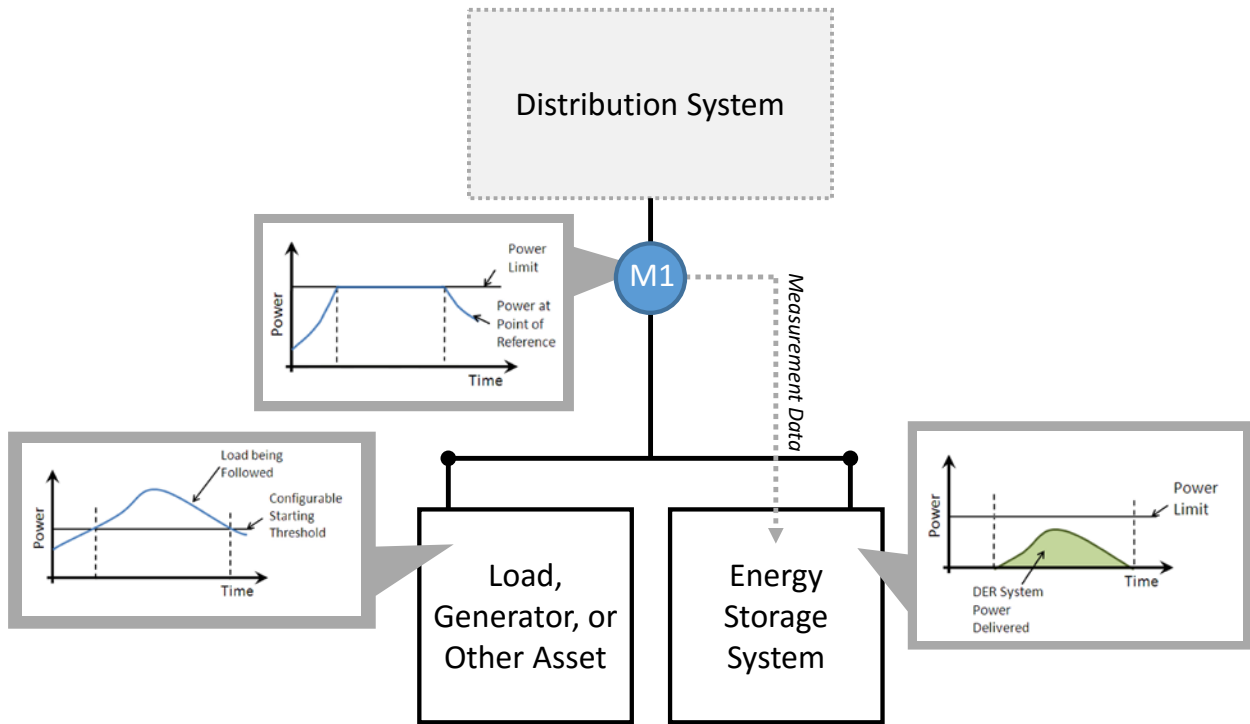

**Figure 21-4**  
**An example implementation of the peak power limiting function for an energy storage system.**

First, the function’s point of reference differs between the two functions. In “Peak Power Limiting” the inverter is provided data from upstream of itself and contains both the inverter’s input/output combined with other assets or loads that are electrically nearby. The inverter changes its output to prevent this measurement point from exceeding the setpoint. In “Load and Generation Following” the inverter is provided data from an asset or load somewhere else on the circuit. The inverter sets its output to match this measurement point to follow the load, generator, or other asset.

The connections are shown in Figure 21-4 for Peak Power Limiting and Figure 21-5 for Load and Generation Following. In Figure 21-4 both the load and the energy storage system are behind the same metering point such that an energy storage system can electrically cancel the load so that neither impacts the distribution system. Alternatively, in Figure 21-5 the two loads are connected by the distribution system but otherwise are not directly connected.

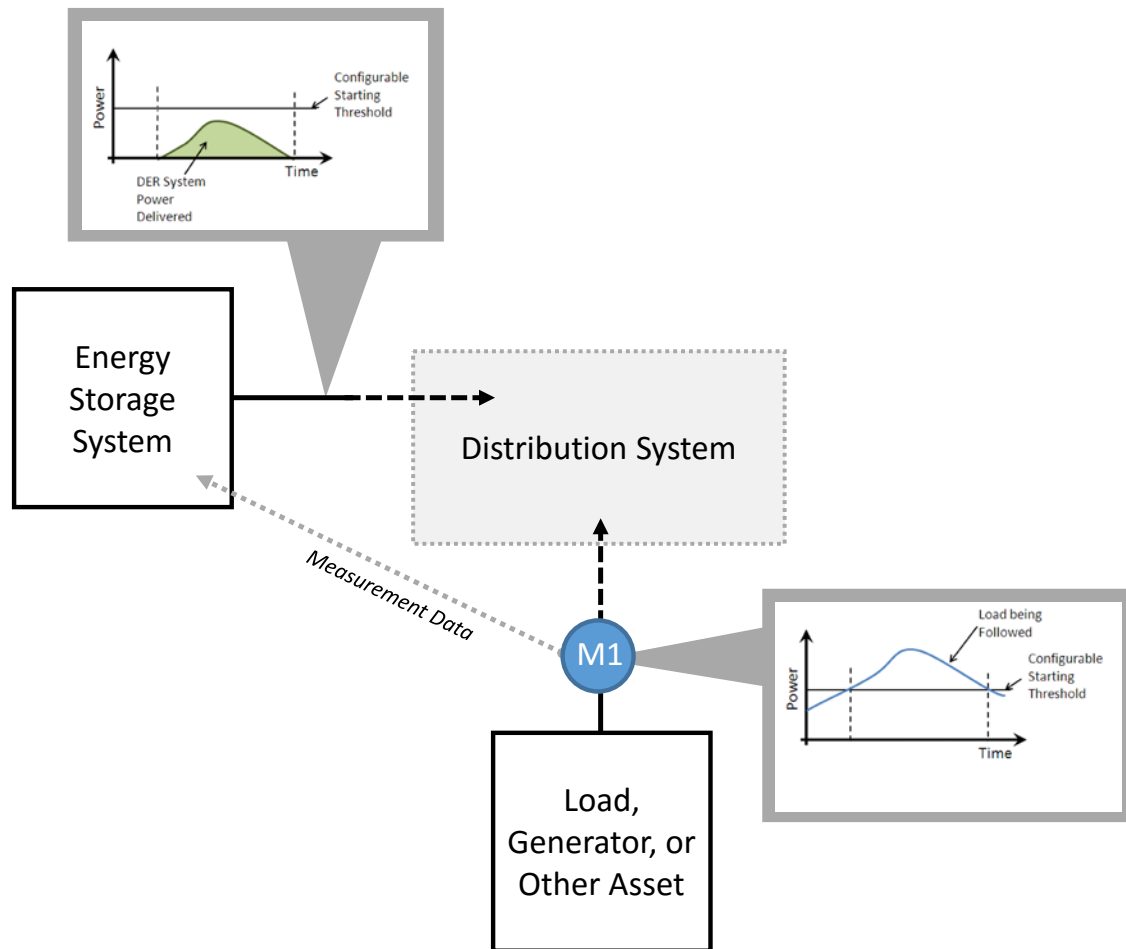

**Figure 21-5**  
**An example implementation of the load and generation following function for an energy storage system.**

Second, the result of the inverter’s response is different between the two functions. In “Peak Power Limiting” the inverter provides output as long and as quickly as it can to prevent the power from exceeding the setpoint. It does not know how much power it must contribute to cause the net power at the point of metering to stay below the setpoint so it must monitor and react to changes. In “Load and Generation Following” the inverter receives data and sets its output to match. Because the inverter is not behind the same metering point as the load/generator it is matching it does not know whether its contributions are actually cancelling the effects of the load/generator. This is why it is called load/generation following because it is following the instructions of the load/generator.

This is shown in Figure 21-4 for Peak Power Limiting and Figure 21-5 for Load and Generation Following. In Figure 21-4 an example is given for discharging an energy storage system. A profile is given for both the load and the energy storage system however the energy storage system only knows what its output is but does not directly know what the profile of the load looks like. The only other information available to it is the data from the meter that both the load and the storage system connect to. Alternatively, in Figure 21-5 the storage system has access to meter data from the load in addition to information about itself.

# 22

## LOAD AND GENERATION FOLLOWING FUNCTION

### Scope of This Function

This proposal is for the Phase 2 Smart Inverter Communication Project, for a Load & Generation Following Function.

This function has initially been identified in relation to distributed energy storage systems. This specification is intended to provide a flexible mechanism through which inverters, such as those associated with energy storage systems, may be configured to provide a following function for loads or generation. This function involves the variable dispatch of energy in order to maintain the power level at the DER output at a level that tracks the level of a reference signal. In the case of load following, the output of the DER power output rises as the consumption of the reference load rises. In the case of generation following, the DER power absorbed increases as the output of the reference generation increases.

### Requirements/Use Cases

Several energy storage system use cases have identified the requirement for this capability. For example:

- San Diego Gas and Electric (SDG&E), Sacramento Municipal Utility District (SMUD), and Southern Company have each independently identified the need for a load/source following function in their specifications for small pad-mount energy storage systems. In one use case, the function is used to have energy flow in/out of the energy system compensate for variability in the generation output of a PV system.
- Several utilities working together in EPRI's storage research program (P94) have developed a specification for a large scale Lithium Transportable Energy Storage System (Li-TESS). This specification includes a requirement for a Load Following function.
- Several use cases compiled in the NIST PAP07 process identified the need for settings that limit the ramp rate of power variations. Also, the PAP 07 use cases identified scheduling mechanisms for managing storage system charging and discharging, one type of "schedule" uses a reference signal rather than time as the controlling signal.

### Prior Bodies of Work

None.

### Proposal

This proposal describes a method by which distributed energy resources (DER) may perform the functions described in the following subsections:

#### ***Load Following***

Load following uses the DER to generate in order to follow the power consumption of a reference load. Figure 22-1 illustrates the concept.

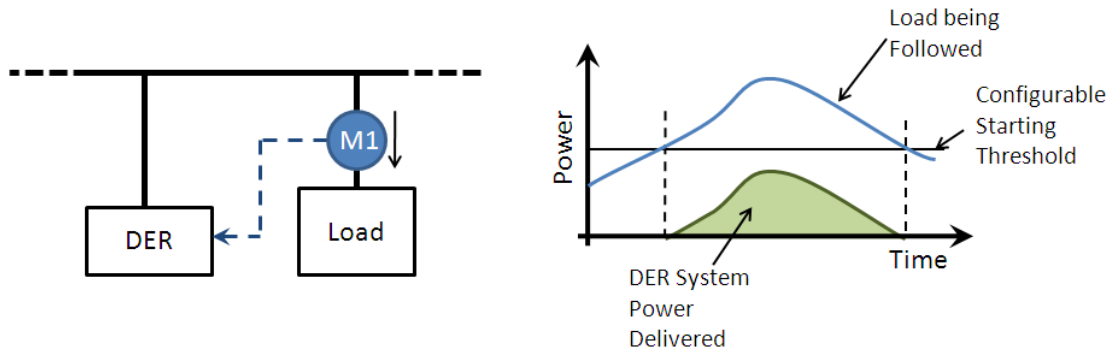

**Figure 22-1**  
**Example load following arrangement and waveform**

As shown in the waveform to the right, this function allows for the use of a “Configurable Starting Threshold”. The DER then produces a power output that is proportional to the level of power consumed by the reference load that is above this threshold.

As indicated in the diagram to the left, this function requires that the DER has access to an indicator of the power level consumed by the reference load. The polarity of this data/signal is such that a positive value indicates power absorbed by the load.

**Generation Following**

Generation following is handled by the same mechanism, with the direction of power flows reversed. Generation following uses the DER to absorb power in order to follow the output of a reference generation device. Figure 22-2 illustrates the concept.

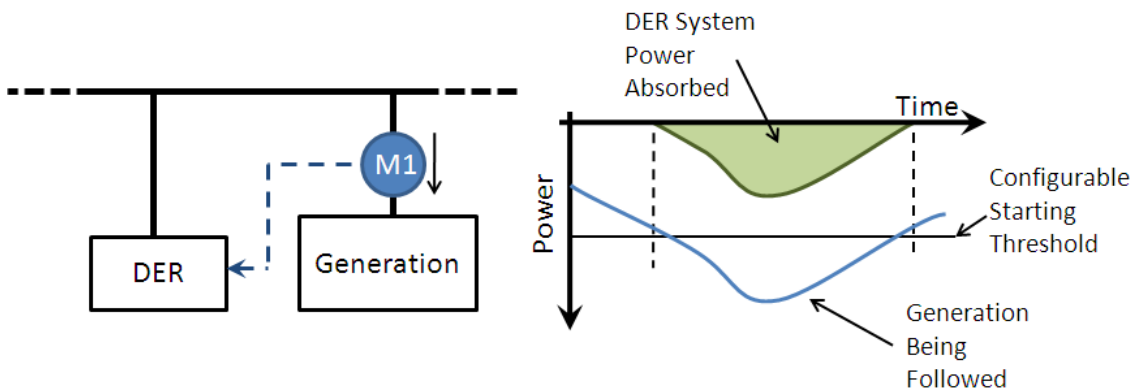

**Figure 22-2**  
**Example generation following arrangement and waveform**

As shown in the waveform to the right, this function uses the same “Configurable Starting Threshold”, but it is now set as a negative quantity to be consistent with the polarity of the signals. The DER then absorbs power at a level that is equal to the level of power output from the reference generator that is below this threshold.

As indicated in the diagram to the left, this function requires that the DER has access to an indicator of the power level produced by the reference generator. The polarity of this data/signal is such that a negative value indicates power produced by the generator.

### ***Allowing for Proportional Load/Generation Following***

The illustrations in Figure 22-1 and Figure 22-2 show the DER following 100% of the load/generation once its magnitude exceeds the configurable threshold. This function, however, allows the “following” to be set to any proportional level by way of a percentage setting. This allows for the possibility that several DER are used collectively to follow a given load.

### **Limitations of the Function**

As with all functions, DER will operate within self-imposed limits and will protect their own components. These limits are acknowledged to vary, depending on many factors (e.g. state of maintenance, damage, temperature). In addition, it is acknowledged that the load/generation following function is limited by present device limit settings, such as WMax.

There are also practical limits to a DER system’s ability to provide load/generation following. For example, an energy storage system cannot follow load or generation indefinitely, and must at some point recharge or discharge in order to continue. One way to handle this is to have other charge / discharge functions active in the background while the load/generation function is also enabled (i.e. they are not mutually exclusive). In this way, the background task could be actively managing the discharging or recharging of the storage device when the load/generation following function is idle due to the starting threshold.

Another method to handle this could include scheduling of the load/generation following modes so that regular charge/discharge commands are used at other times.

### ***Point of Reference for Load/Generation Following***

It is outside the scope of this specification to dictate to the DER how the measurement data from the point of reference is to be acquired. The idea is that when a load/generation following function is supported and enabled, the manufacturer will have built into the product the knowledge of the proper source(s) for the reference data and the user will have set-up and configured the product properly. Examples include:

- A product might include a local measurement that is used for load/generation following.
- A product might use a local communication port to interface with a nearby reference measurement for load/generation following.
- A product might use a local analog input to represent the reference measurement.
- A product might be designed to receive (pulled or pushed) reference measurement from a remote system via the standard communication interface.

## Settings to Manage This Function

The following settings are defined to manage this function:

**Table 22-1**  
**Settings for the load and generation following function**

Setting Name	Description
Enable/Disable Load/Generation Following Mode	This is a Boolean that makes the mode active or inactive.
Starting Watt Threshold	This is a configurable threshold, below which load following does not occur. In the case of generation, this is the threshold above which generation following does not occur. Expressed in Watts. The Starting Watt Threshold may be set to a positive value, a negative value, or zero.
Load/Generation Following Ratio	This is a configurable setting that controls the ratio by which the DER follows the load once the magnitude of the load exceeds the threshold. This setting is a unit-less percentage value.  As an example, consider a DER that is following load, with a present load level of 200KW, a threshold setting of 80kW and a following ratio setting of 25%. The amount of the load above the threshold is 120kW, and 25% of this is 30kW. So the output power of the DER would be 30kW.
Reference Point Power Level	This is the power measurement in Watts which the DER is using as the reference for load/generation following. From the perspective of this function, this quantity is read-only. As discussed previously, it is the responsibility of the DER manufacturer and user to configure and establish how the DER acquires this measurement.
Ramp Times	This is a fixed time in seconds, over which the inverter settings (Watts in this case) are to transition from their pre-setting level to their post-setting level. The purpose of this parameter is to prevent sudden changes in output as a result of the receipt of a new command. Note: this setting does not impact the rate of change of Watt output during run-time as a result of power changes at the reference point.  There are four individual ramp times for this function, <ul style="list-style-type: none"> <li>• Ramp Time – Increasing</li> <li>• Ramp Time – Decreasing</li> <li>• Ramp Time_ - Increasing and Charging</li> <li>• Ramp Time – Decreasing and Charging</li> </ul>
Time-Out Window	This is a time after which the setting expires. A value of zero means to never expire. After expiration, the Peak-Power Limit settings would no longer be in effect.

# 23

## DER SETTINGS TO MANAGE MULTIPLE GRID CONFIGURATIONS (INCLUDING ISLANDING)

### Definitions

Grid Configuration – this term is used to refer to the grid or power system into which the DER is connected. Specifically, it recognizes that this power system may change for a variety of reasons, including switch operations that might reconfigure the circuit (e.g. networked feeders), formation of large area or small area islands, alternate modes of grid operation, etc. These are referred-to as “Grid Configurations” herein.

### Scope of This Function

This proposal is for the Phase 2 Smart Inverter Communication Project, for the communications needed to provide DER with alternate settings that may be needed when the local grid configuration changes, such as islanding and circuit switching. This includes communications to help the DER understand when a change in the grid configuration has occurred and also the settings to define how the various functions of the inverter are to behave for each grid configuration.

As indicated in Figure 23-1, the scope of this document:

1. Is generally NOT intended to define the behaviors of an “island management system” such as would manage the local grid once islanded. The exception to this is the case of a PV or storage inverter that includes an integral islanding switch which separates the inverter and downstream loads from the utility grid.
2. Does NOT manage the settings or methods by which a PV or storage inverter determines that unintentional islanding has occurred (e.g. frequency change, impedance, various sensors)
3. Does NOT override or interfere with any protection functions such as low-voltage disconnect

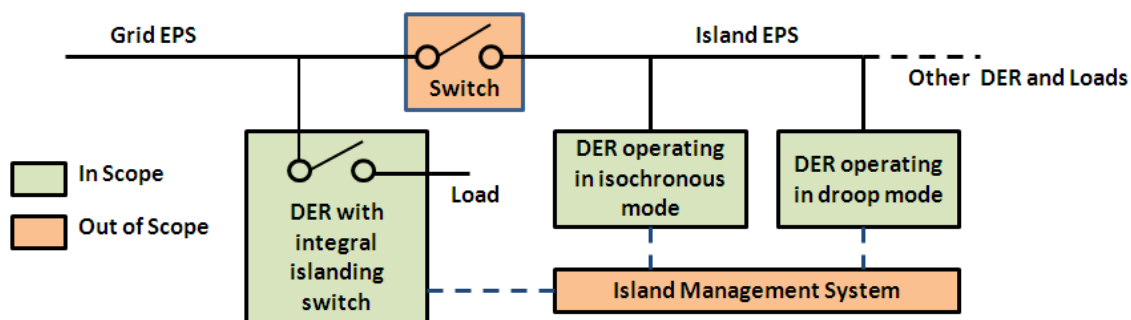

Figure 23-1  
Island diagram

## Requirements/Use Cases

From the perspective of a DER, this function may be associated with a number of use cases. The examples identified in Table 23-1 provide insight into the range of these uses and were considered in the development of this function description.

**Table 23-1**  
**Example use cases**

	Event Description	Single Device	Many devices
1	Uninterruptible Power Supply (UPS) function: Coasting into an island – catching the system before an outage occurs	Device is alone sustaining the island, or otherwise is operating in an isochronous mode	Device is one of many in an island, and is operating in a droop / following mode
2	Restarting in an island		
3	Pre-planned (scheduled) island formation		
4	Circuit reconfiguration (many types)		
5	Loss of communication		
6	Default settings (factory, initial install)		

This function serves the following specific uses:

1. Provides a communication mechanism through which settings may be provided to a PV or storage inverter to establish the desired behavior during a loss of communication
2. Provides a communication mechanism through which a PV or storage inverter can be informed that a change has occurred in the local grid configuration, such as intentional islanding or switching to an alternate substation
3. Provides a communication mechanism through which a PV or storage inverter can be set to either isochronous or droop mode to support various islanding conditions
4. Provides for communication of the range of settings needed to instruct the PV or storage inverter as to the desired behavior during the various alternative grid configurations, such as when islanded.
5. Provides a communication mechanism to instruct a PV or storage inverter to island, in the case that the inverter system includes an integral islanding switch.

## Prior Bodies of Work

IEEE 1547.4 presents the principles of DER Islanding in detail. These principles have been used as a guide to establish what needs to be communicated to a smart inverter in relation to intentional islanding.

## Proposal

This proposal recognizes that in tightly-coupled system architectures, the DER may be connected via a high-bandwidth, high-availability communication system. Through such a system, the DER might be uniquely reconfigured, near instantly, at the time of a grid reconfiguration such as islanding. In such a case, the DER may need only limited additional settings. In loosely-coupled architectures, however, system bandwidth and other factors may limit the ability to uniquely

modify settings in an individual DER, and more autonomous, distributed intelligence may be needed. It is intended that the settings put forth in this proposal will cover both cases.

### Multiple Settings Groups

As illustrated in Figure 23-2, it is proposed that inverters may have the ability to store multiple copies of the settings that manage their various functions. The IEC 61850 includes the idea of “Settings Groups” which contain a collection of individual settings. This concept is utilized here, with a complete copy of the inverters settings in each settings group. Although it may be argued that only a subset of the inverter’s settings need to be changed when the Grid Configuration changes, it is suggested here that it is simpler in the context of a communication specification to consider each setting group as a complete set, with each set being identical in structure. Manufacturers may, of course, limit which parameters are changeable through their configuration software tools and inverter design limitations and may store settings inside their products anyway they wish.

The rationale for this approach is based on inverter manufacturer input distinguishing between complexity and memory storage. It is suggested that inverter complexity is actually reduced if the content of each “Settings Group” are of identical structure. Programmers of the inverters behavior thus always have the same data structure (the same range of settings) to deal with.

In terms of the actual memory required to store these multiple settings groups, it is suggested that the total configuration data volume associated with these functions, including schedules, is small by present memory technology standards, and does not result in any significant burden, even for small residential inverters.

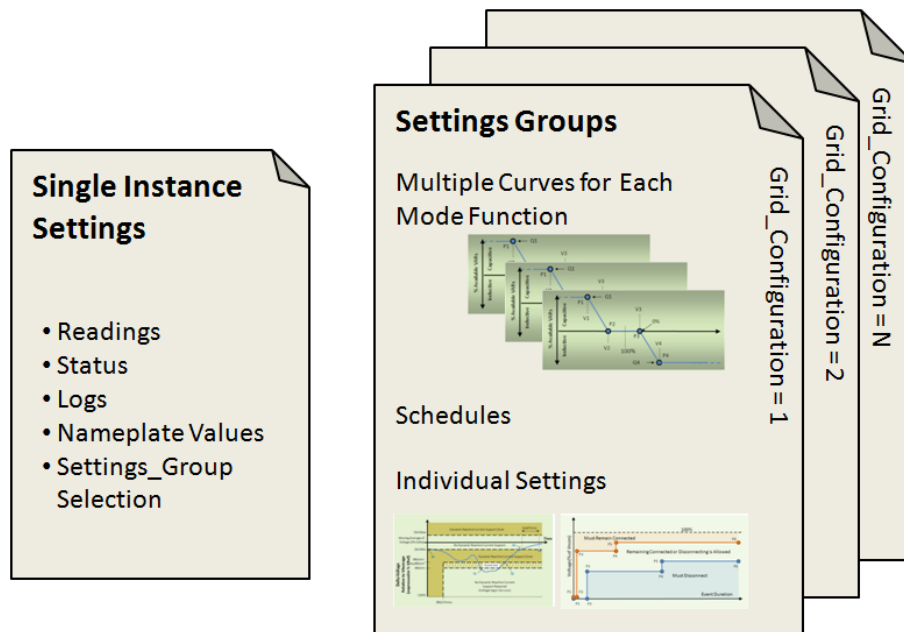

Figure 23-2  
Illustration of multiple settings groups

As illustrated to the left in Figure 23-2, there are a few readable and/or writeable parameters that cannot logically exist multiple times, and are set-aside as exceptions, kept out of the settings groups. Table 23-2 indicates which settings are NOT included in the multiple “Settings Groups” instances.

**Table 23-2**  
**Data excluded from settings groups**

Name	Description
Status Data	This data represents the present readable status and measurements of the local device that are not “Grid_Configuration” related, such as local voltage, frequency, hours of service, temperature, etc. Refer to IEC 61850-90-7 and the DNP3 application note for smart inverters.
Event Logs	This data represents the historical activity and event log for the inverter as specified in IEC 61850-90-7 and the DNP3 application note for smart inverters.
Nameplate Values	This data represents the device capability information that is generally static. Refer to IEC 61850-90-7 and the DNP3 application note for smart inverters.
Settings_Group Controls	The settings identified herein in Table 23-3 that manage the settings groups.

***Manufacturer Choice***

Just as manufacturers may choose which standard functions to support, it is suggested that they may also choose to limit which settings are actually different from one “Settings Group” to another.

For example, an inverter configuration software could present a user with an interface through which all the inverters configuration settings may be selected. This software could also associate these settings with a particular “Settings Group” such as “Normal Grid Connected Configuration”. When the user then continues to the next step, to create settings for an alternative “Settings Group” such as “Islanded”, it may be that only certain fields are changeable, with others being grayed-out and held constant with the settings of the normal grid configuration.

***Writing and Activating Settings Groups***

Figure 23-3 can be used to explain the proposal further, illustrating how individual settings groups can be written-to, read-back to verify and activated.

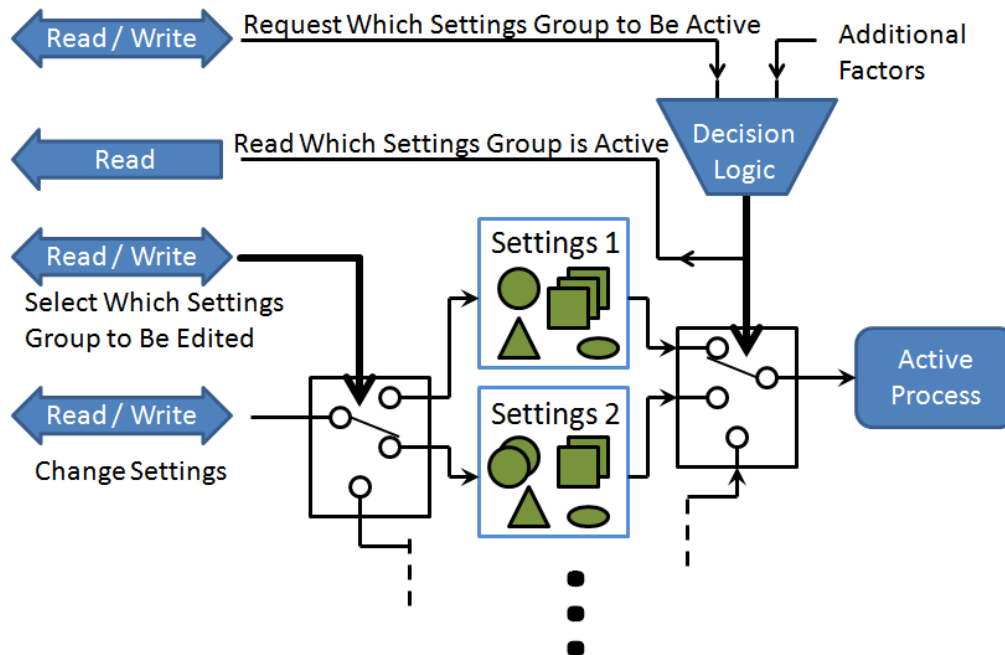

**Figure 23-3**  
**Reading, writing and activating settings groups**

The boxes in the center of the figure represent the various settings groups, with the green shapes inside each box representing the various settings, arrays, schedules, and other parameters that are included in each group.

The switch shown to the left provides a means by which a user can write-to a selected settings group. The group being written-to may or may not be presently active.

The switch shown to the right determines which settings group is presently active. As indicated by the “Decision Logic” block, the active settings group may be determined by whatever is presently requested via the communication channel, but may also be determined by a range of additional factors.

***Parameters to Manage This Function***

To support this capability, the following settings are proposed. Each enumerated value implies that the inverter should transition (or has transitioned) to an associated Settings Group:

**Table 23-3**  
**Settings for managing multiple grid configuration**

Name	Description
Requested_Settings_Group	<p>This is a readable/writeable enumeration that identifies the Settings Group that was most recently requested to be activated through a communication setting/request.</p> <ul style="list-style-type: none"> <li>0 = Not Used</li> <li>1 = Unspecified / Autonomously Determined*</li> <li>2 = Factory Configuration</li> <li>3 = Default Configuration / Communication Lost</li> <li>4 = Normal Grid-Connected Configuration</li> <li>5 = Islanded Condition 1 (small, local island)</li> <li>6 = Islanded Condition 2 (larger, area island)</li> <li>7 = Islanded Condition 3 (largest, regional island)</li> <li>8 = 1<sup>st</sup> Alternate Grid Connected Configuration</li> <li>9 = 2<sup>nd</sup> Alternate Grid Connected Configuration</li> <li>10 = 3<sup>rd</sup> Alternate Grid Connected Configuration</li> <li>11-255 = Reserved for future assignment</li> </ul> <p>*Note: Enumeration = 1 may only be set if Enable_Sensed_Grid_Config_Detection = 1</p>
Active_Settings_Group	<p>This is a read-only enumeration that identifies the Grid Configuration that is presently in effect.</p> <p>Note: This reading may differ from what was last set using the “Requested_Settings_Group” parameter, depending on a variety of circumstances and the manufacturer’s logic for responding to these circumstances as illustrated in Figure 23-4.</p> <ul style="list-style-type: none"> <li>0 = Not Used</li> <li>1 = Unspecified / Autonomously Determined*</li> <li>2 = Factory Configuration</li> <li>3 = Default Configuration / Communication Lost</li> <li>4 = Normal Grid-Connected Configuration</li> <li>5 = Islanded Condition 1 (small, local island)</li> <li>6 = Islanded Condition 2 (larger, area island)</li> <li>7 = Islanded Condition 3 (largest, regional island)</li> <li>8 = 1<sup>st</sup> Alternate Grid Connected Configuration</li> <li>9 = 2<sup>nd</sup> Alternate Grid Connected Configuration</li> <li>10 = 3<sup>rd</sup> Alternate Grid Connected Configuration</li> <li>11-255 = Reserved for future assignment</li> </ul>
Enable_Sensed_Grid_Config_Detection	<p>This is a readable/writeable Boolean that indicates whether or not inverter is to independently change its Active_Settings_Group based on a locally observed grid conditions.</p> <ul style="list-style-type: none"> <li>0 = No Autonomous detection. Inverter shall not consider local grid conditions (e.g. voltage, frequency) only.</li> <li>1 = Autonomous detection. Inverter’s “Active_Settings_Group” may differ from the “Requested_Settings_Group” if so detected.</li> </ul>

Name	Description
Settings_Group_Being_Edited	<p>This is a readable/writable enumeration that identifies the Settings Group whose associated settings group is presently selected for editing. All settings made for functions, schedules, etc will be directed to the settings group associated with this Grid Configuration.</p> <ul style="list-style-type: none"> <li>0 = Not Used</li> <li>1 = Unspecified / Autonomously Determined*</li> <li>2 = Factory Configuration</li> <li>3 = Default Configuration / Communication Lost</li> <li>4 = Normal Grid-Connected Configuration</li> <li>5 = Islanded Condition 1 (small, local island)</li> <li>6 = Islanded Condition 2 (larger, area island)</li> <li>7 = Islanded Condition 3 (largest, regional island)</li> <li>8 = 1<sup>st</sup> Alternate Grid Connected Configuration</li> <li>9 = 2<sup>nd</sup> Alternate Grid Connected Configuration</li> <li>10 = 3<sup>rd</sup> Alternate Grid Connected Configuration</li> <li>11-255 = Reserved for future assignment</li> </ul>

### Determining Active Settings Group

As indicated in Table 23-3, each settings group is associated with a specific condition, such as a grid configuration, loss of communication, factory default, etc. The inverter's Active\_Settings\_Group may differ from the Requested\_Settings\_Group. This difference may depend on a variety of factors, as illustrated in Figure 23-4.

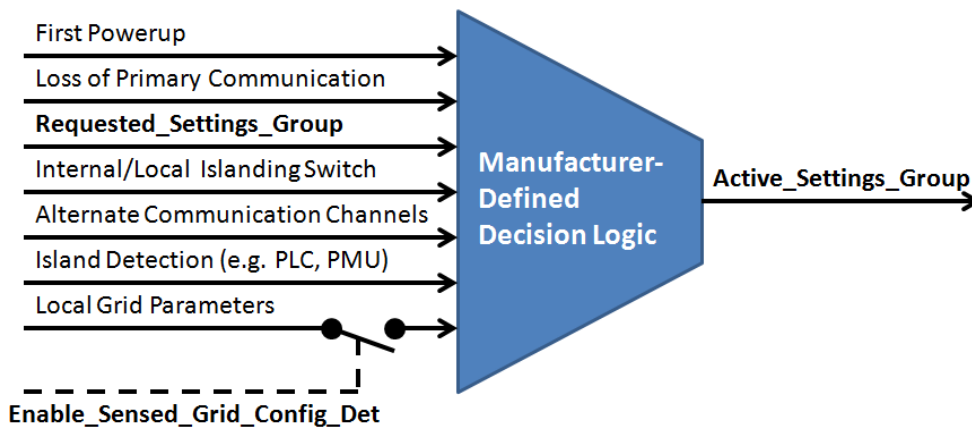

**Figure 23-4**  
Determining the active settings group

The decision logic by which a DER determines the currently active settings group is outside the scope of this specification. As indicated in bold on the left side of Figure 23-4, the settings defined herein, “**Requested\_Settings\_Group**” and “**Enable\_Sensed\_Grid\_Config\_Detect**”, are among the parameters that may factor into this logic.

## Examples of Active\_Grid\_Configuration Logic

For devices such as padmount energy storage that include an integral islanding switch, the settings identified in Table 23-2 may be used to manage the behavior of the islanding switch.

- The **Enable\_Sensed\_Grid\_Config\_Detection** setting may be used to determine whether the integral islanding switch operates only in response to received requests or also based on local conditions. For example, if it is desired that the system islands automatically to maintain power to customers during a grid outage, then the **Enable\_Sensed\_Grid\_Config\_Detection** setting shall be set to “1”.
- The **Requested\_Settings\_Group** setting may serve as the request mechanism to affect the state of the internal islanding switch remotely. For example, if a distribution management system wishes to intentionally island a padmount energy storage system, then the **Requested\_Settings\_Group** setting could be changed from its previous value (e.g. from a setting of 4 to 5).

If communications are determined to be lost, then the DER logic may set the **Active\_Settings\_Group** to 3 (Default Configuration / Communication Lost). The method of detection of communication loss is outside the scope of this specification. Depending on the nature of the communication system, momentary loss of communication may be normal, and DER action based on loss of communication may not take effect until after some unspecified period of time.

The communication interface provides one possible means through which a PV or Storage inverter may be informed (e.g. by the utility, local EMS, etc.) that the power system configuration has changed (e.g. an island has formed and it is now part of that island). This is represented in the **Requested\_Settings\_Group** parameter as defined in Table 23-2. It is also useful to be able to read-back this set value.

### ***Managing Isochronous/Droop Modes and Reconnection***

It is proposed that the DER can be provided with a setting, as shown in Table 23-4, that determines, in any islanded configuration, whether it is to operate in a voltage and frequency controlling mode (referred-to as “isochronous”) or a droop mode (referred-to as “droop”).

**Table 23-4**  
**Isochronous/droop setting**

Name	Description
Isochronous_Droop_Control	This is a Boolean setting: 0 = Isochronous 1 = Droop

Isochronous mode is intended to be something like a PID control mode in which the isochronous machine attempts to control to an absolute value of frequency and voltage, independent of Watt/VAR load, up to the limits of the machine’s capabilities. In isochronous mode, the previously-defined active smart inverter functions such as Volt/Var do not apply because the goal of exactly controlling the output voltage and frequency stipulates the machine’s behavior.

Devices in droop mode are intended to follow the isochronous device(s). They will do this by utilizing the previously defined Volt/VAR curve function and Frequency/Watt curve function, using the alternate settings as defined for the particular islanded condition, to achieve the desired droop characteristics. In effect, the isochronous machine operating in an islanded scenario assumes the role played by the utility in a non-islanded scenario.

Figure 23-5 and Figure 23-6 illustrate the behaviors of isochronous and droop machines.

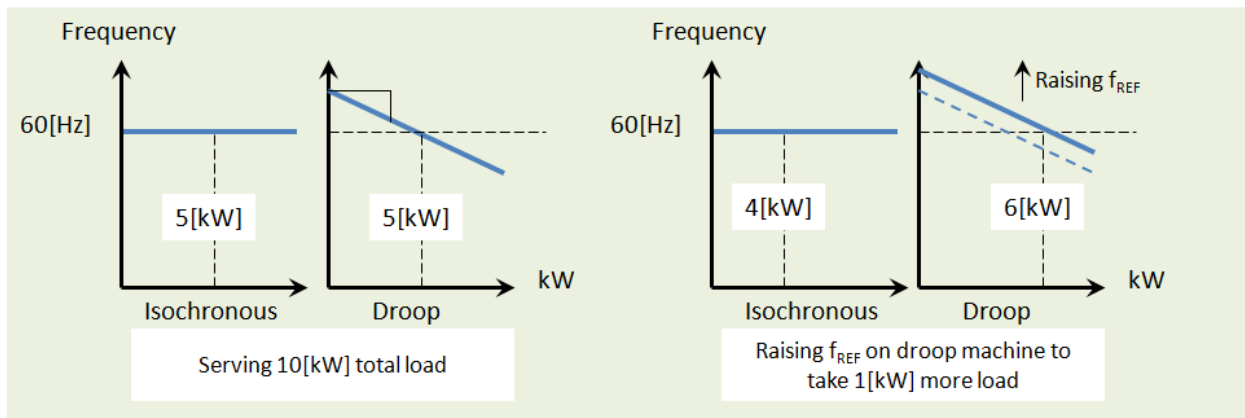

**Figure 23-5**  
**Isochronous vs. droop watt behaviors relative to frequency**

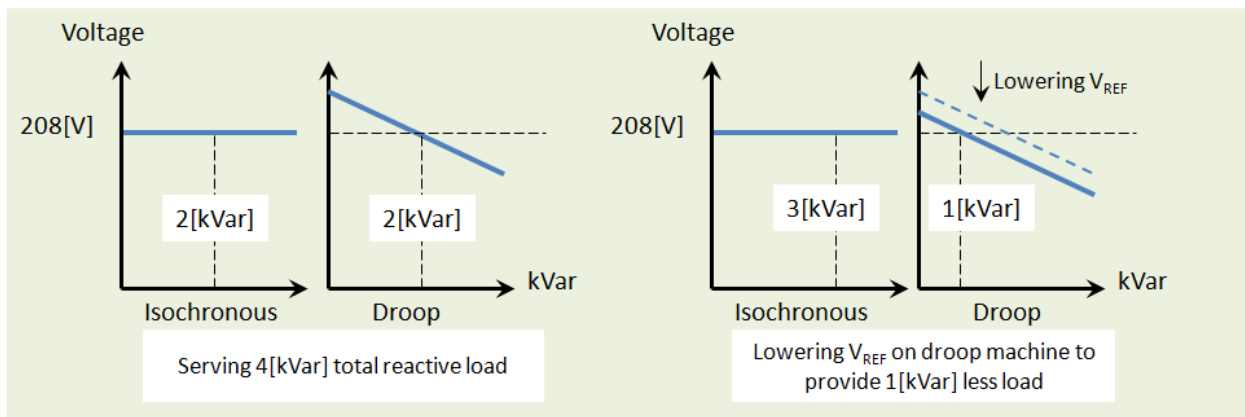

**Figure 23-6**  
**Isochronous vs. droop var behaviors relative to voltage**

As illustrated in these figures, machines operating in droop mode may shift their Watt output in response to frequency and may shift their Var output in response to Voltage. These characteristics are traditionally defined in terms of a “No Load Frequency” and “Frequency Droop Gradient” to establish the sloping lines shown in Figure 23-5, and similarly a “No-Load Voltage” and “Voltage Droop Gradient” to establish the sloping lines shown in Figure 23-6.

### Reuse of Existing Settings in Islanded, Isochronous & Droop Modes

When operating in islanded mode, several previously-defined parameters and functions are to be utilized to provide for the desired isochronous and droop behaviors. Specifically:

**Establishing the Isochronous Voltage Target:** When an inverter is in an islanded condition (Active\_Settings\_Group = 5, 6, or 7), AND in isochronous mode (Isochronous\_Droop\_Control = 0), then the previously-defined Vref setting becomes the indicator of voltage to which the isochronous machine controls using PID control mode.

**Establishing the Isochronous Frequency Target:** When an inverter is in an islanded condition (Active\_Settings\_Group = 5, 6, or 7), AND in isochronous mode (Isochronous\_Droop\_Control = 0), then the previously-defined Fnominal setting becomes the indicator of frequency to which the isochronous machine controls using PID control mode.

**Establishing the Droop No-Load Voltage:** When an inverter is in an islanded condition (Active\_Settings\_Group = 5, 6, or 7), AND in droop mode (Isochronous\_Droop\_Control = 1), the Droop No-Load Voltage is that voltage at which the capacitive VAR output is zero. This is to be established using the previously-defined Volt/VAR curve function, which is relative to the Vref setting.

**Establishing the Voltage Droop Percent Gradient:** When an inverter is in an islanded condition (Active\_Settings\_Group = 5, 6, or 7), AND in droop mode (Isochronous\_Droop\_Control = 1), the VAR output of the machine in droop mode varies from its output at Vref according to the Volt/VAR curve that is active for this islanded condition.

**Establishing the Droop No Load Frequency:** When an inverter is in an islanded condition (Active\_Settings\_Group = 5, 6, or 7), AND in droop mode (Isochronous\_Droop\_Control = 1), the Droop No-Load Frequency is that frequency at which the Watt output is zero. This is to be established using the previously-defined Frequency-Watt curve function, which is relative to Fnominal.

**Establishing the Frequency Droop Percent Gradient:** When an inverter is in an islanded condition (Active\_Settings\_Group = 5, 6, or 7), AND in droop mode (Isochronous\_Droop\_Control = 1), the Watt output of the machine in droop mode varies from its output at Fnominal according to the Frequency/Watt curve that is active for this islanded condition.

# 24

## WATT-VAR FUNCTION

### Scope of This Function

This function is intended to provide a flexible mechanism through which a general Watt-VAR function could be configured, if so desired. When in this mode, the DER shall actively control the reactive power output as a function of the real power output following a target real power – reactive power (Watt-Var or P-Q) curve. It is not intended to suggest that such a function is necessary or to specifically define how it should be configured if used.

### Requirements/Use Cases

This function under consideration by the working groups involved in the IEEE P1547 revision process.

### Prior Bodies of Work

None referenced.

### Proposal

It is proposed that a combination of a configurable array and individual parameters be used to control the Watt-VAR function. The approach for transmitting and storing arrays is not unique and applies to all curve based functions including Watt-PF, Volt-VAR, and Volt-Watt.

In these functions the array is a piece-wise linear “curve” that the inverter will follow. The real-power output will define the reactive power output of the inverter. Figure 24-1 demonstrates this concept. In this example, as the real power increases past 50% the VAR output increases. If the power drops the VAR input decreases. At 50% it stops generating VARs. As the active power goes up and down the VAR output changes following the curve.

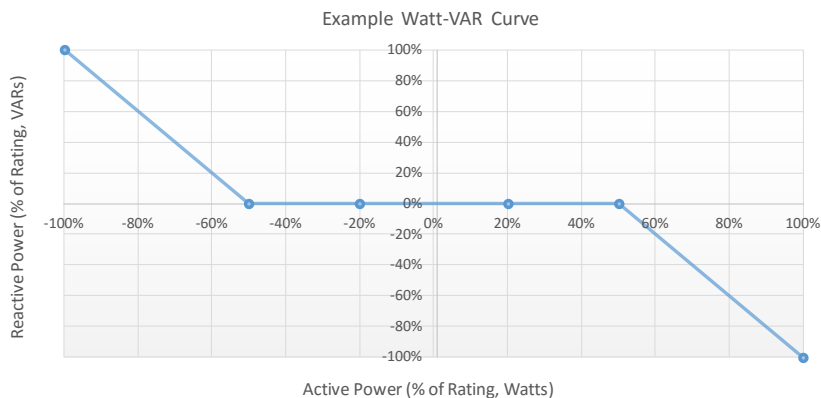

**Figure 24-1**  
Example watt-VAR array

Each array will have a variable number of points, which together define a piece-wise linear curve of the desired Watt-VAR behavior. In the example of Figure 24-1, there are 6 points. The configuration array will include for each point a wattage and a desired VAR level.

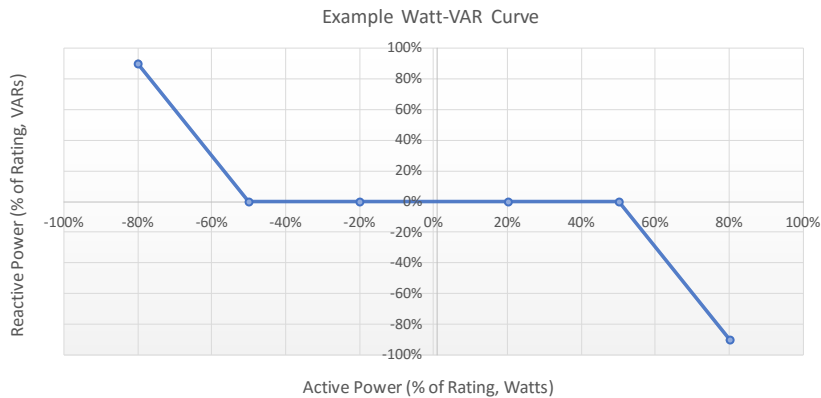

**Figure 24-2**  
**Example watt-VAR array where the curve does not extend the full width of the inverter’s active power operating range**

By definition, the desired VAR level is assumed to remain constant for above the highest wattage point or below the lowest wattage point. As shown, the first point in the Watt-VAR configuration is to be the lowest wattage point and the last the highest wattage, with the wattage increasing or holding the same for each successive point. An example of this is shown in Figure 24-2. The curve does not span the full range from 100% active power to -100% active power. The dotted line indicates the expected behavior for the portion not addressed by the user defined curve.

### Defining Valid Volt-Watt Configuration Arrays

Different protocol mappings and/or different products may have different limitations regarding Volt-Watt curve configurations. This may include the maximum number of points and maximum power (active and reactive). The minimum and maximum X and Y coordinates may also be defined by grid requirements and manufacturer constraints. It is the duty of purchasers to determine requirements and the duty of manufacturers to define the constraints for their products regarding what configurations are valid. Invalid configuration attempts may result in an error response.

### Defining Reactive Power, the Array Y-Values

The Y-values in the Watt-VAR settings are defined as percent of rated reactive power. Two modes are available for the y-axis.

### Percent of Maximum Rated Apparent (VA) Power

In the case where an inverter does not have a VAR rating the operator can use the rating on apparent power to determine 100% VARs. This is different than “Percent of Maximum Rated Reactive Power with VARs Precedence” because sometimes the manufacturers put limits on VARs that are smaller than VA. If Max VARs is equal to VA, then they are the same. Refer to the Volt-Var Function for more information.

## Percent of Maximum Rated Reactive Power with VARs Precedence

In this mode the y-axis is percent of the rating for reactive power. VARs precedence means that the function will sacrifice watts to provide the requested VARs if the VA limit of the inverter is exceeded. Refer to the Volt-Var Function for more information.

## Defining Active Power, the Array X-Values

The x-axis of the Watt-VAR curve is a percent of active power rating. Positive values correspond to WMax and negative values, WChaMax. WMax and WChaMax may not be equal. Refer to the Volt-Var Function for more information.

## Additional Parameters Affecting Watt-VAR

- **Timeout Window:** A time, after which the Watt-VAR mode is disabled. This timeout window begins when the mode becomes effective (as a result of a direct command or schedule). A value of zero shall be used to indicate that the setting does not expire.
- **Ramp Rates:** The maximum rate at which VAR output may transition from its prior value to its new target value when this mode first becomes effective. This setting does NOT affect the ramp rate of VAR output in response to varying voltage or varying availability of VARs (e.g. from a variable PV source). Similar to other functions, this includes four ramp rates depending on whether the system is charging or not and whether the change is an increase or decrease.
  - Ramp Rate – Increasing
  - Ramp Rate – Decreasing
  - Ramp Rate – Increasing, Charging
    - ESS Only
  - Ramp Rate – Decreasing, Charging
    - ESS Only

## Editor's Notes

Watt-VAR being considered for inclusion in IEEE 1547. At the time of publishing this report the function was still in development. The authors of this report believe that the function descriptions above may change once IEEE 1547 is updated and ratified however it is unlikely that the basic curve concept defined above will change.



# 25

## GUIDELINES FOR PRECEDENCE OF SETTINGS

This specification identifies several types of limits and intelligent control functions for distributed energy resources. Several of these will typically be in effect simultaneously and in many cases multiple limits or control functions that affect the same parameter, such as Watt or VAR output, may be active at the same time.

The purpose of this section is to specify the way these settings behave when simultaneously active and, where necessary, to establish an order of precedence.

As defined elsewhere in this document, the VA limit of an inverter links its real and reactive capabilities and the settings for VAR output when using Volt-VAR control can be with either Watt or Var precedence. This chapter adds to this, but providing specific guidance for precedence among the VAR-managing and Watt-managing functions.

### Settings Affecting Watt Output

The DER's Watt output may be affected by the settings identified in Table 25-1, according to order of precedence.

**Table 25-1**  
**Precedence of watt related functions**

Priority	Settings/Functions	Description
1 <sup>st</sup> (Fundamental Physical Limits)	Energy Source or Self-Imposed Limits (safety, etc.)	A system cannot produce power that it does not have available and may have other practical limits related to its present circumstances. Although these limitations do not show up as controls, they do establish the ultimate limits of the system. This would include any limits on Wattage that result from availability of solar resources or limits that an inverter imposes on itself, based on thermal conditions, errors, failures, etc. No other setting or condition may cause an inverter to violate these self-imposed limits.
2 <sup>nd</sup> (Nameplate and Device Limits Settings)	WMax Capability Setting WMaxCha Capability Setting	This is the configurable setting establishing the DER's maximum Wattage input / output at the Electrical Connection Point (ECP). This establishes the maximum allowed output from the DER at any time in terms of Watts. Higher or Lower priority settings may reduce the Wattage output below this value, but nothing may increase it above this value. Nameplate Watt rating is for informational purposes and has no direct effect on Watt output.
3 <sup>rd</sup> (Settings Actively Affecting Operating Boundaries)	Limit DER Power Output Function	These intelligent functions all serve to reduce maximum allowed Watt level to some percentage of its WMax Capability less than 100%. The information that cause these reductions to occur varies (e.g. undesirable voltage, undesirable frequency, utility command).
	Frequency-Watt Control	
	Frequency-Watt Control Function with Snapshot Capability	These functions may be simultaneously active. Their relative priority is equal. The one requiring the greatest reduction in Watts (lowest percent output at any time) takes precedence.
	Voltage-Watt Control	As functions intended to establish operating boundaries, these functions are higher priority than any of the dynamic (priority 4) of

Priority	Settings/Functions	Description
	Watt-Var Function	steady-state (priority 5) functions. Those functions may be active at the same time as these functions, but must operate (even dynamically) within the boundaries established by these functions.
4 <sup>th</sup> (Dynamic Functions: Transiently Active)	Dynamic Real-Power Support	These are dynamic functions, and produce “Additional” Watts that add-to or subtract-from whatever the present output power level may be based on unrestrained generation or one of the 5 <sup>th</sup> priority functions listed below.
	Dynamic Volt-Watt Function	These two functions are of equal priority, but are never in conflict because they produce <u>additive</u> Watts. Both can be simultaneously active, adding to whatever Watt levels might otherwise be produced.
5 <sup>th</sup> (Steady state functions managing Watt input/output)	Direct Charge/Discharge Storage Function	Each of these functions, when used, serve to manage the flow of real power into or out-of the DER.
	Pricing Signal Function	These four functions are mutually exclusive and cannot be active simultaneously.
	Peak Power Limiting Function	These functions have a lower order of priority than those above and may not, at any time, result in the prevention of the 4 <sup>th</sup> -priority dynamic functions to operate or in a violation of the Watts limits set by any of the Priority 3 Boundary-Setting Functions that are active.
	Load/Generation Following Function	For example, consider a device that is currently scheduled to discharge its battery at 80% of its max discharge rate, and this amounts to 3KW. If this same system has A WMax capacity setting of 5KW, but is currently under a 50% reduction limit due to a Watt-Voltage function, then total power out from the storage and any local PV may not exceed 2.5KW.
	Isochronous Mode (see Islanding Function)	

### Settings Affecting VAR Output

The DER’s VAR output may be affected by the settings identified in Table 25-2, according to order of precedence.

**Table 25-2  
Precedence of VAR Related Functions**

Priority	Settings/Functions	Description
1 <sup>st</sup> (Fundamental Physical Limits)	Self-Imposed Limits	A system may have practical limits related to its present circumstances that limit its ability to produce VARs. Although these limitations do not show up as controls, they do establish the ultimate limits of the system at any time. This would include any limits on VARs that an inverter imposes on itself, based on thermal conditions, errors, failures, etc. No other setting or condition may cause an inverter to violate these self-imposed limits.
2 <sup>nd</sup> (Nameplate and Device Limits Settings)	VARmax Capability Setting	This is the configurable setting establishing the DER’s maximum VAR output at the Electrical Connection Point (ECP). This establishes the maximum reactive power output from the DER at any time in terms of VARs. Higher or Lower priority settings may reduce the VAR output below this value, but nothing may increase it above this value. Nameplate VAR rating is for informational purposes and has no direct effect on VAR output.

Priority	Settings/Functions	Description
3 <sup>rd</sup> (Settings Actively Affecting Operating Boundaries)	None Defined for VARs at this Time	
4 <sup>th</sup> (Dynamic Functions: Transiently Active)	Dynamic Reactive Current Support Function	This is a dynamic function, and produces “Additional” reactive current that adds-to or subtracts-from whatever the present reactive current level may be based on one of the 5 <sup>th</sup> priority functions listed below.
5 <sup>th</sup> (Steady state functions managing VAR input/output)	Adjust Power Factor Function	<p>These functions instruct the DER as to the desired level of VARs to produce at any time. For each function (Power Factor, Volt-VAR Function, and Watt-VAR Function), the VAR level is indirectly related to the Watt output.</p> <p>These functions have equal priority, but are never in conflict because they are <u>mutually exclusive</u> and only one may be effective at any time.</p> <p>In the event of confusion where commands regarding both functions are being received by the DER, the most recent function to be made active by either direct command or by schedule shall take effect. For example, consider a DER that has a Volt-VAR schedule that specifies Volt-VAR Array Mode 1 from 4PM until 8PM, and Volt-VAR Array Mode 2 at all other times. If this system switched to Volt-VAR Array Mode 1 at 4PM, then at 5PM received an INV3 Power Factor setting, the Power Factor would take effect and remain in effect until 8PM when Volt-VAR Array Mode 2 would resume.</p>
	Volt-VAR Function	
	Watt-VAR Function	
	Watt - Power Factor Function	
	Isochronous Mode (see Islanding Function)	



# 26

## STATUS MONITORING POINTS

Many functions require the status of the inverter either periodically, on significant change of a value, or upon request. How different protocols may implement these reporting requirements is outside the scope of these specifications, but as a minimum, reporting status upon request is expected.

Throughout this document a variety of configuration settings and limits are identified. It is intended that each of these settable parameters can also be monitored or read back at any time.

This section identifies additional quantities (not identified elsewhere in this document) that may also be read from the device. Some of these may be writeable and others may be fixed by the manufacturer or set only with special or local access.

The following status points are defined:

**Table 26-1**  
**Status points**

Status Point	Description
<b>Primary Information</b>	
Connected time	Total time (since commissioning) that the DER has been connected to the power system
Operating time	Total time (since commissioning) that the DER has been operating
Connect/disconnect switch status	Whether or not the device is currently connected at its ECP
PV present	(Yes) This DER site includes PV / (No) It does not
Storage present	(Yes) This site includes storage / (No) It does not
VAR capability present	(Yes) This DER can provide reactive power / (No) It can not
Present Operating Mode	Identity of mode or function that the PV/Storage is in. (details according to the specific protocol used, for example, an enumeration with range reserved for vendor proprietary modes)
<b>Detailed Information</b>	
Inverter status	Inverter is switched on (operating), off (not able to operate), or in stand-by mode (capable of operating but presently not operating)
DC Voltage	Voltage on the DC source connected to the inverter. (Volts)
DC Current	Current to/from the DC source connected to the inverter. (Amps)
Local/Remote control mode	Indicates whether the inverter is controlled locally or remotely.
Reactive power setpoint	Value of the output reactive power setpoint. (VARs)
Power factor setpoint	Value of the power factor setpoint.
Nominal frequency setpoint	Value of the frequency setpoint. (Hertz)

Status Point	Description
Type of connection point	An enumeration – detailed by the particular protocol mapping. To include: unknown, DER to local load, DER to local EPS, local EPS with load to area EPS, local EPS w/o load to area EPS, other
Type of circuit phases	An enumeration – detailed by the particular protocol mapping. To include: unknown, single phase, 3-phase, delta, wye, wye-grounded, other
<b>Energy/Power Measurements</b>	
Inverter active power	Present real power (Watts). This is an instantaneous (minimal averaging) reading. A positive sign is power output which is the same as generating and also the same as the energy storage is discharging. A negative sign is power input which is the same as consuming (like a load) and also the same as the energy storage is charging.
Inverter reactive power	Present reactive power (VARs, leading or lagging). This is a signed quantity. Sign relates to inductive (lagging or negative) or capacitive (leading or positive) reactive power.
Power Factor	Power factor at the connection point.
Present line frequency	The present frequency of the power system. (Hertz)
Active power at the ECP	Active power at the PCC. (Watts)
Reactive power at the ECP	Reactive power at the PCC. (VARs)
Phase-to-ground voltages	Voltage values per phase. (Volts)
Voltage angles	Angle measurements of each phase. (Degrees)
Power factor and limits	Power factor value (including sign), plus high and low limits.
Real energy generated	Real energy supplied to grid (Watt-hours)
Real energy received	Real energy received (demanded) from grid (Watt-hours)
Reactive energy supplied	Reactive energy supplied to grid (VAR-hours)
Reactive energy received	Reactive energy received (demanded) from grid (VAR-hours)
DC inverter power input	Used for determining efficiency of inverter. (Watts)
<b>Energy Storage State of Charge</b>	
Actual Energy	The total energy the energy storage medium can deliver at a specified temperature. See Figure 26-1. (Watt-hours)
Maximum Usable State of Charge	The maximum usable state of charge is a parameter that defines the maximum permissible level a system can be charged to. See Figure 26-1. (% of Actual Energy)
Actual State of Charge	The actual state of the charge of the energy storage system is the percent of the total energy available. See Figure 26-1. (Watt-hrs)
Minimum Usable State of Charge	The minimum usable state of charge is a parameter that defines the minimum permissible level a system can be charged to. See Figure 26-1. (% of Actual Energy)
Usable Energy	The total energy that can be dispatched from the energy storage system. This is defined as the energy in between the Maximum Usable State of Charge and Minimum Usable State of Charge Parameters. See Figure 26-1. (Watt-hours)

Status Point	Description
Maximum Reserve Percentage	A reserve percentage that the user may define. The storage system will not charge above this amount until the reserve percentage is changed. See Figure 26-1. (% of Usable Energy)
Usable State of Charge	The state of charge of the system in comparison to the usable capacity – the total amount of watt-hrs available to the user. See Figure 26-1. (% of Usable Energy)
Minimum Reserve Percentage	A reserve percentage that the user may define if desired. The storage system will not discharge below this amount until the reserve percentage is changed. See Figure 26-1. (% of Usable Energy)
Maximum storage charge rate	The maximum rate of energy transfer into the storage device. (Watts) This establishes the reference for the charge percentage settings in function PC4a.
Maximum storage discharge rate	The maximum rate of energy transfer out of the storage device (Watts) This establishes the reference for the discharge percentage settings in function PC4a.
Inverter Input Voltage	Internal storage voltage (Volts)
<b>Nameplate and Settings Information</b>	
Manufacturer name	Text string
Model	Text string
Serial number	Text string
Inverter nameplate power rating	The continuous power output capability of the inverter (Watts)
Inverter nameplate VA rating	The continuous Volt-Amp capability of the inverter (VA)
Inverter nameplate VAR rating	Maximum continuous VAR capability of the inverter (VAR)
Time resolution	Time resolution and precision
Source of time synchronization	Text string

The retrieval of status items may be undertaken using various methods. These methods are highly dependent on the particular protocol mapping. Examples include:

- Single status values:
  - On-demand, request a single status value. That status value is then returned to the requester.
  - Upon a status value change or upon exceeding a dead-band or upon exceeding a limit (depending upon the type of status point), that status value will be transmitted
- Sets of status values:
  - During initialization of the DER system, sets of status values could be assigned to one or more “data sets”. These data sets could then be used in the following ways:
    - On-demand, request one of these data sets. All of the status values in the requested data set will be returned to the requester
    - Periodically, all of the status values in each data set will be transmitted
    - Upon change or upon exceeding a deadband or upon exceeding a limit of a status point in the data set, all of the status values in the affected data set will be transmitted

- After initialization, using the communications network, data sets could be created, modified, and/or deleted, and the reporting triggers can be established (e.g. upon demand, periodically, upon change).

Using an “on-demand” retrieval method, the following command and response actions could be included:

**1. “On-demand” request:**

- a. Status command
- b. Identity of which status value or which data set

**2. Response to an on-demand request:**

- c. Requested status value(s)
- d. Timestamp
- e. Quality of status value(s)
- f. Failed (plus reason : equipment not available, message error, security error)

For other retrieval methods, other “unsolicited” information could be transmitted, such as:

**Periodic, or upon change of a status value:**

- a. Status value(s)
- b. Timestamp
- c. Quality of status value(s)

**State of Charge (Energy Storage Systems)**

Energy storage systems are unique because their primary purpose is to provide energy flexibility on the grid. Operators manage this flexibility by raising and lowering the state of charge of the system, power, and rate of change of the system. There are two sets of state of charge parameters. Some are useful to communicate and others are likely only applicable within the energy storage system itself. Both will be explained below to highlight the differences.

To further break this down, two groups of stakeholders were identified; 1) installers, manufacturers, battery management systems and other internal components, and those involved in the procurement process, 2) operators of the system including utilities, aggregators, and Independent System Operators (ISO). Each has a unique set of parameters. Those in the first group tend to apply to the design parameters of the system. Those in the second group apply to the application of the system. This distinction is important. The parameters are broken into two groups, actual energy – the set of parameters most likely to be used by installers, manufacturers, battery management systems and other internal components, and those involved in the procurement process – and usable energy – the parameters most likely to be used by operators, utilities, aggregators, and others that control or dispatch the system. There are exceptions to this however it is expected this is typically the case.

The parameters vary by energy, power, and VARs.

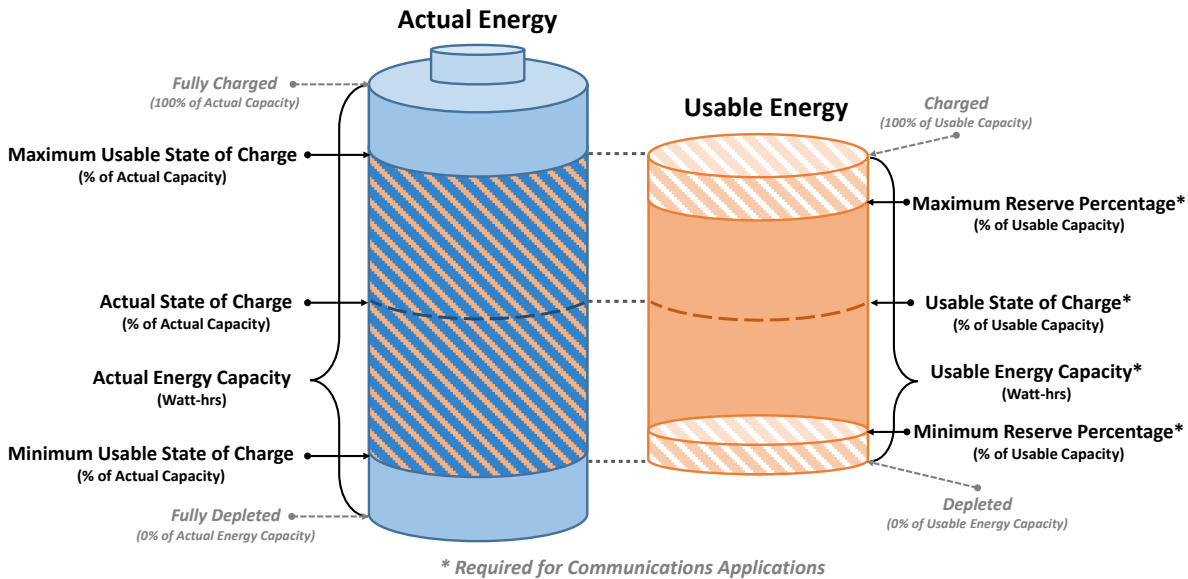

**Figure 26-1**  
**State of charge – actual and usable energy and their associated parameters**

The parameters for energy include:

### Actual Energy

- Actual Capacity (Watt-hrs)
  - The total Watt-hrs a system is able to store.
- Maximum Usable State of Charge (% of Actual Capacity)
  - The maximum usable state of charge is a parameter that defines the maximum permissible level a system can be charge to. This is based on system design. This defines the max charge for Usable Energy. It is possible that this parameter is equal to fully charged. (100% of actual capacity).
  - This parameter is optional.
- Minimum Usable State of Charge (% of Actual Capacity)
  - The minimum usable state of charge is a parameter that defines the maximum permissible level a system can be charged to. This is based on system design. This defines the minimum charge for Usable Energy. It is possible that this parameter is equal to fully depleted (0% of actual capacity).
  - This parameter is optional.
- Actual State of Charge (% of Actual Capacity)

The actual state of the charge of the energy storage system is the percentage of energy available at a specified temperature. This is used by the energy storage system components including the battery management system.

### Usable Energy

- Usable Capacity (Watt-hrs)
  - The amount of energy in Watt-hrs that can be delivered by the energy storage system. This is determined by the amount of energy between the maximum usable state of charge and the minimum usable state of charge.
- Usable State of Charge
  - The state of charge of the system in reference to the usable capacity – the total amount of Watt-hrs available to the user.

Note: This parameter different than Actual State of Charge because it references 0% Usable Energy Capacity as its minimum and 100% Usable Energy Capacity as its maximum. In comparison Actual State of Charge uses 0% Actual Energy Capacity and 100% Actual Energy Capacity. These can be different values but may not be.

- Maximum Reserve Percentage (% of Usable Capacity)
  - A reserve percentage that the user may define if desired. The storage system will not charge above this amount until the reserve percentage is changed.
- Minimum Reserve Percentage (% of Usable Capacity)
  - A reserve percentage that the user may define if desired. The storage system will not discharge below this amount until the reserve percentage is changed.

### ***Operation Regions for Energy Storage Systems***

Limits and their associated regions are also suggested during implementation. These parameters should be considered optional. These limits are applicable to the “actual” settings and provide guidance to operators and controllers and to provide greater flexibility in utilization of the ESS. Three regions are identified. It is understood that the rate at which energy is removed from the system can impact the life of the energy storage system’s elements, depending on the energy storage technology. It is also expected that the dispatcher has knowledge of the system that allows them to decide when it is appropriate to change the min and max usable state of charge to push the system into different operating regions when deemed appropriate including times of urgent need or favorable economics.

The following examples focus on energy (state of charge) but the concepts could apply to power (charge/discharge rate) which are not discussed here.

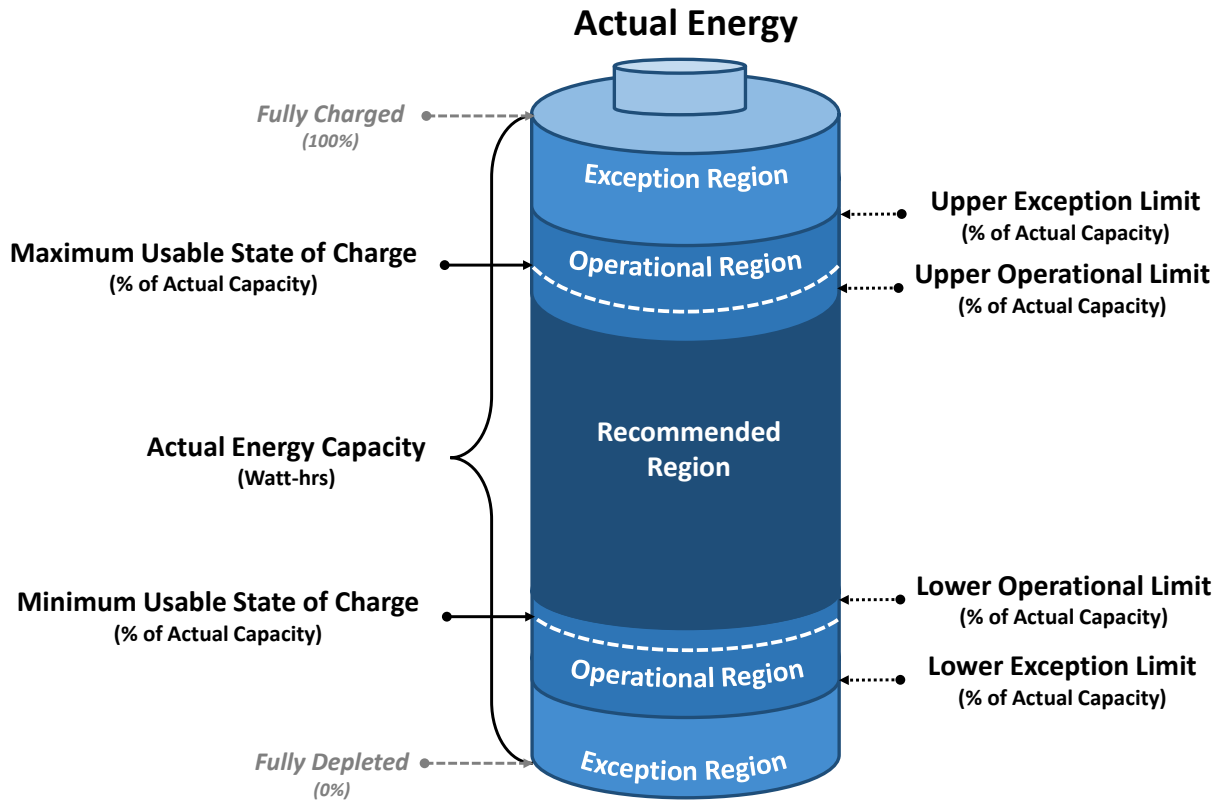

**Figure 26-2**  
**The different operating region for energy storage systems**

- **Exception Region**
  - The lower most charge limit and the upper most charge limit within the exception region. The operational limit for the Exception Region is an upper limit at which a system can be charged or the lower limit at which a system can be discharged but with some impact to lifetime or maintenance. This region will not be used intentionally but may be entered incidentally as the device changes operating modes.
- **Operational Region**
  - The lower most charge limit and upper most charge limit within the operational region. The operational limit is an upper limit at which a system can be charged or the lower limit at which a system can be discharged but with some impact to lifetime or maintenance. This region will be used in special situations as the discretion of the operator.
- **Recommended Region**
  - The recommended limit is the charge boundaries recommended by the manufacturer to meet lifetime and other build requirements set forth at or before commissioning of the system. This region is normal operation.

Each of these regions are defined by a limit. A limit is the easiest way to communicate the boundaries of a region. Figure 26-2 demonstrates the relationship of the regions and their associated limits.

- Upper Exception Limit (% of Actual Capacity) - Alarm
- Upper Operational Limit (% of Actual Capacity)
- Upper Recommended Limit (% of Actual Capacity) – Maximize life / recommendation – normal circumstances
- Lower Operational Limit (% of Actual Capacity)
- Lower Recommended Limit (% of Actual Capacity) – Maximize life / recommendation – normal circumstances
- Lower Exception Limit (% of Actual Capacity) - Alarm

### ***Applications for the Types of State of Charge***

This document does not define what must be considered for the reserve percentages or min/max state of charge. This document defines that their inclusion is helpful for making informed decisions about operation of the system.

The group identified a few examples of how to use the parameters and the regions they define described above. For example, the Minimum/Maximum state of charge can change because of factors including storage degradation, impacts from varying charge and discharge rates, ambient temperature, maintenance, and whether certain operating parameters must be obeyed to reach the advertised life. Some other examples of drivers that may cause an operator to change the system's minimum and maximum state of charge are given below.

### **Minimum/Maximum State of Charge**

- State of health
- Aggressiveness of charging/discharging
- Weather and climate considerations in design of the system.
- Number of cycles completed / Energy throughput
- Maintenance
- Warranty considerations

The reserve setpoints depend on the applications the storage system is used for including the following:

### **Minimum/Maximum Reserve Percentage**

- Backup Power / Micro-grid – likely a customer use case to maintain a commercial facility
- Arbitration on a Distribution Level
- Time dependent use-cases
- Reserve for bidding resources
- Bounding the abilities of automatic functions to reserve energy for other services

## **Editor's Notes**

State of Charge section was added because there was confusion on the terminology around state of charge. Depending on the user of the system these parameters had different meanings. It was concluded that the best approach was to give each a unique name and definition. By embracing the differences users of the system could be sure the parameter used matches the desired outcome.



# 27

## EVENT LOGGING AND REPORTING

### Scope

This proposal is for the Phase 1 Smart Inverter Communication Project, for an ability to perform event logging and reporting. This initiative is defining a toolkit of functions that are being defined using a standardized model which can then be mapped into a variety of protocols.

None of the functions being described through this initiative are necessarily “mandatory” from an implementation perspective – actually requiring certain functions to be implemented is the purview of regulators and of the purchasers of systems. The works into which this function will be added state that “if a function is to be implemented, then it should be implemented according to these specifications”.

This specification is intended to provide a common mechanism for inverters to log and report a standardized set of events.

### Requirements/Use Cases

The participants in this initiative indicated a high priority on the need for a common method for event logging and reporting. This was based on the sense that there are many uncertainties and unknowns regarding smart inverter functions, and that particularly in the early years, it is important to monitor the behaviors of inverters and to flag abnormal conditions and events.

Having at least a beginning set of uniform event codes and (through protocol mappings) a common way to log and report these events was considered a requirement.

### Proposal

All event log entries will contain (at least) the following 5 fields:

1. **Date and Time Stamp:** The accuracy of this timestamp will be determined by the frequency of time synchronization and the innate precision in keeping time of the PV system, and is therefore outside the scope of this specification. Zeros can be used to pad any timestamp if the accuracy does not match the format.
2. **Data Reference:** the reference to the data item that triggered the event log entry. For instance, if it is a voltage-related event, the Data reference will be to that data object. If it is a PV Mode event, the Data Reference will be to the PV Mode data object.
3. **Value:** Value field of the Data reference field that is triggering the event, including commands, state changes of monitored values, quality code changes, mode setting, etc. For instance, the request to go into a specific PV mode will be logged with the Value containing the PV mode identity.
4. **Event Code:** 4-part code to uniquely identify the type of event – see Table 24-1.
5. **Optional Text Field:** Text of supporting information. This text will not be standardized, but can be used to provide additional details about the event.

To enable the filtering of events so that different users can select different types of events to retrieve, event “codes” are established. These event codes are based on the IEC 61968-9 (CIM for distribution) event codes, with additions as necessary to address inverter events. The Event Code standard contains many codes, with only a small fraction relevant to PV/Storage systems. The more important ones (including additional ones) are described in Table 27-1 below, but different implementations may choose different sets of event types, including vendor-specific and/or implementation-specific event types.

The codes are built from 4 levels: Domain, Part, Type, and Attribute. In this Specification, four existing domains are used:

- Communications (for communication-related events)
- Grid power (for power system events)
- Device asset (for time and asset-related events)
- Security (for security-related events)

And two new domains are defined:

- PV system (for PV inverter events, as well as other PV events)
- Storage system (for storage inverter events, as well as other storage events)

In the table below, a Storage system, if separate from a PV System, would have the same event codes except for changing “PV System” to “Storage System” with a D# code of 22 instead of 21.

Various communication protocols (e.g. DNP3) approach event logging and reporting in different ways. This specification will employ those existing mechanisms, with details being identified in the protocol mapping documents.

Ideally, users will have the ability to filter requests for events from the logs by Domain, Part, Type and Attribute, so that only those events of interest may be collected. Also, it is envisioned that the communication protocols will provide for reading only new events, or those not previously reported.

Additional event log interactions could include:

- Notification if event log is almost full or completely full without having been retrieved
- Notification of an event log error

**Table 27-1**  
**Standard event codes**

Domain	D#	Part	P#	Type	T#	Attribute	A#	Description
Comms	01	Messaging	19	Status	17	Success	244	Request received successfully. Value field identifies the request as a "demand response"
Comms	01	Messaging	19	Status	17	Success	244	Command received successfully. Value field identifies the command as a "Direct command"
Comms	01	Messaging	19	Status	17	Acknowledged	3	Response – acknowledgment sent
Comms	01	Messaging	19	Alarm	1	Message failed	156	Response – alarm invalid message. Value field contains type of error.
Comms	01	Network interface	23	Alarm	1	Comm. failed	32	Alarm communications error. Value field contains type of error.
PV System	21	Inverter	51	Command	6	Success	244	Action taken successfully (details are provided in Mode and Command events)
PV System	21	Inverter	51	Command	6	Failed	85	Requested action failed. Value field contains type of error.
PV System	21	Inverter	51	Command	6	Deviation	65	Action taken is a deviation from the requested action. Data Reference and Value fields contain indication of this deviation
PV System	21	Mode	22	Status	17	PV Mode	302	Inverter is in one of the PV modes, as indicated in the Value field
PV System	21	Inverter	51	Command	6	PC Command	303	Inverter responded to one of the PC commands, as indicated in the Value field
PV System	21	Inverter	51	Status	17	Limit exceeded	139	Inverter status changed due to internal control threshold exceeded. Data Reference and Value fields provide details
PV System	21	Schedule	52	Schedule change	31	Success	244	Action was successfully taken in response to the scheduled requirement
PV System	21	Schedule	52	Schedule change	31	Failed	85	Action failed in response to the scheduled requirement. Value field indicates the type of error
PV System	21	Power	26	Status	17	Power out	185	Inverter power turned off
PV System	21	Power	26	Status	17	Power on	216	Inverter power turned on
PV System	21	Power	26	Alarm	1	Power out	185	Power tripped off due to internal situation
PV System	21	Power	26	Alarm	1	DC Voltage	301	Inadequate DC bus voltage, Value field provide measured value
PV System	21	Power	26	End alarm	9	DC Voltage	301	DC bus voltage within limits. Value field provide measured value
PV System	21	Temperature	35	Alarm	1	Limit exceeded	139	Temperature limit exceeded. Value field contains type of error.
PV System	21	Temperature	35	End alarm	9	Limit exceeded	139	Returned within temperature limit. Value field contains type of error.
Grid Power	6	ECP Switch	31	Status	17	Connected	42	Switch at the ECP between inverter and the grid is connected

Domain	D#	Part	P#	Type	T#	Attribute	A#	Description
Grid Power	6	ECP Switch	31	Status	17	Disconnected	68	Switch at the ECP between inverter and the grid is connected
Grid Power	6	Voltage	38	Alarm	1	Limit exceeded	139	Voltage limit exceeded. Value field contains voltage measurement.
Grid Power	6	Voltage	38	End alarm	9	Limit exceeded	139	Returned within voltage limit. Value field contains voltage measurement.
Grid Power	6	Voltage	38	Alarm	1	Limit exceeded	139	Voltage distortion limit exceeded. Value field contains voltage distortion.
Grid Power	6	Voltage	38	End alarm	9	Limit exceeded	139	Returned within voltage distortion limit. Value field contains voltage distortion.
Grid Power	6	Current	6	Alarm	1	Limit exceeded	139	Current limit exceeded. Value field contains current measurement.
Grid Power	6	Current	6	End alarm	9	Limit exceeded	139	Returned within current limit. Value field contains current measurement.
Grid Power	6	Power quality	28	Alarm	1	Limit exceeded	139	Harmonic limit exceeded. Value field contains harmonic measurement.
Grid Power	6	Power quality	28	End alarm	9	Limit exceeded	139	Returned within harmonic limit. Value field contains harmonic measurement.
Grid Power	6	Other 1547 parameters? ?		Alarm	1	Limit exceeded	139	?? limit exceeded
Grid Power	6	Other 1547 parameters? ?		End alarm	9	Limit exceeded	139	Returned within ?? limit
Device asset	2	Logs	17	Status	17	Almost full	8	Log is almost full. Value contains percentage full.
Device asset	2	Logs	17	Alarm	1	Full	304	Log full: new events to overwrite unread events
Device asset	2	Time	36	Alarm	1	Clock failed	29	Clock failure. Value contains error information.
Device asset	2	Time	36	Alarm	1	Synch failed	252	Synchronization failed. Value contains error information
Device asset	2	Time	36	Setting	16	Synchronized	254	Synchronized. Value contains delta between new time and old time
Device asset	2	Time	36	Setting	16	Daylight adjust	254	Daylight time or Standard time adjustment. Value indicates Daylight of Standard
Device asset	2	Firmware	11	Alarm	1	Data error	52	Data error detected in firmware. Value indicates type of error

# 28

## TIME ADJUSTMENT FUNCTION

The ability to set the time in the DER device was deemed a requirement, in order to support the scheduling of functions, and the time-stamping and logging of events.

Research indicated that time-adjustment is generally already supported by the specific communication protocols into which these functions will be mapped. In view of this, the recommended approach for time-adjustment for distributed smart inverters is to utilize the native time –adjustment mechanism of the specific communication protocol being applied. For example, the DNP3 protocol and the ZigBee Smart Energy Profile 1.0 protocol have defined time-setting mechanisms that may be used for synchronizing smart inverter devices.

Details to be included in individual protocol–mapping documents.



# 29

## CONCLUSIONS

The Smart Inverter Communication Initiative engaged more than 500 individuals representing inverter manufacturers, system & solution providers, utilities, universities and both private and public research organizations worldwide. The effort began in 2009, Phase 2 work was completed in August of 2012, and additions/corrections were made in 2013. At this time, the participants concluded that a next-phase effort should be delayed and will be best informed by vendor implementation and field experimentation, and that the present list of functions is complete enough at this time.

A significant number of volunteers from this initiative have met weekly/biweekly over the last four years to select and define a common way that each function might be implemented. This document presents the results of this effort. This work has been adopted by standards organizations and has been used to support a wide range of standardization and design activities worldwide.

EPRI has turned attention to smart inverter field demonstrations, including a supplemental smart inverter demonstration project and a Department of Energy award on the same topic. It is anticipated that the process of field demonstration will provide insights into the errors and ambiguities in the existing function descriptions. It is also expected that this and related processes will help to identify those functions that are of greater market interest. In parallel with these field activities, EPRI is starting a project that looks at the enterprise interactions (software to software) that are needed to support DER integration with other utility systems such as Distribution Management Systems (DMS), Geospatial Information Systems (GIS), and Meter Data Management Systems (MDMS).

Both utilities and manufacturers of smart, inverter-based systems are encouraged to employ these functions in their planning and specifications. As additional functional needs are identified, and as gaps and ambiguities in these functions are identified, users are encouraged to bring those insights back into the standardization process so that these methods can be improved.

A next-phase initiative is envisioned once sufficient experimentation and learning has come from work with the present materials. The plan for the next phase is to focus first on corrections/revisions to the present set of functions, then on any new functions for which a need has been identified.

Until a common set of functions are identified and adopted, it is not possible to create open communication standards. And without communication standards, there is no interoperability. In order for the full potential of distributed PV and storage systems to be realized, standards will be required that enable a wide range of device types, sizes and brands to operate together, providing uniform services in response to uniform controls. This initiative and this body of work are a contribution toward this cause.



# A

## **FUTURE TOPICS FOR DISCUSSION**

Often during meetings, calls, and working groups topics are brought up that are not settled. It may be because of limited time, waiting for action from other stakeholder groups, or disagreement across stakeholders. Regardless of the reason, these topics are important for the industry. This section is a reference for future revisions and serves to acknowledge the rapidly changing landscape for smart inverters. Some of these topics may be included in this report in the future and others may be left to both grid code and communications standards to decide.

### **Accuracy and Sampling Rate**

How do users know the precision and sampling rate of time for outputs of functions? Is it needed and if so how should it be captured?

### **Access Permissions**

How do system owners control which users are permitted to view data, issue settings and control commands? Is this impacted by operational states (e.g. normal, lockout, maintenance)?

### **Reconnection Process**

Inverters can be disconnected from the grid but continue to run to provide energy to local loads. This may require additional attention on the reconnection process both at the device level and group level functions. Connect/disconnect functions existing but it is less clear whether resynchronization must occur before reconnection for systems.

### **Addition of Alarms**

There has been advancement in alarms in the industry. An opportunity exists for a group to focus on updating the alarms, the impact they have on currently enabled functions, and how the alarms should be handled.

### **Scheduling of Functionality for Storage Systems**

Scheduling exists for the “Energy Storage: Coordinated Charge / Discharge Management Function” but scheduling is lacking in other functions.

### **Ramp Times and Ramp Rates**

Historically both ramp times and ramp rates have been used. This document acknowledges both but times are used for some functions and rates on others.

### **Referenced ECP**

Referenced ECP is the concept of changing the reference point of functions from the default value (ECP for most functions) to a remote monitoring point. Advocates of the concept say that it will provide additional flexibility in functionality and help inverters to be aware of other devices within the same plant. More information is needed about how changing the reference

point of these functions impacts their design and whether instead of adding capabilities to reference external measurement points, new functions should be added that are dedicated to the task.

### **Constant VARs Function**

The Fixed Power Factor Function allows users to change the power factor of an inverter. It was mentioned that it would be helpful to set the reactive power output of the inverter as another mode to the Fixed Power Factor Function.



## **Export Control Restrictions**

Access to and use of EPRI Intellectual Property is granted with the specific understanding and requirement that responsibility for ensuring full compliance with all applicable U.S. and foreign export laws and regulations is being undertaken by you and your company. This includes an obligation to ensure that any individual receiving access hereunder who is not a U.S. citizen or permanent U.S. resident is permitted access under applicable U.S. and foreign export laws and regulations. In the event you are uncertain whether you or your company may lawfully obtain access to this EPRI Intellectual Property, you acknowledge that it is your obligation to consult with your company's legal counsel to determine whether this access is lawful. Although EPRI may make available on a case-by-case basis an informal assessment of the applicable U.S. export classification for specific EPRI Intellectual Property, you and your company acknowledge that this assessment is solely for informational purposes and not for reliance purposes. You and your company acknowledge that it is still the obligation of you and your company to make your own assessment of the applicable U.S. export classification and ensure compliance accordingly. You and your company understand and acknowledge your obligations to make a prompt report to EPRI and the appropriate authorities regarding any access to or use of EPRI Intellectual Property hereunder that may be in violation of applicable U.S. or foreign export laws or regulations.

**The Electric Power Research Institute, Inc.** (EPRI, [www.epri.com](http://www.epri.com)) conducts research and development relating to the generation, delivery and use of electricity for the benefit of the public. An independent, nonprofit organization, EPRI brings together its scientists and engineers as well as experts from academia and industry to help address challenges in electricity, including reliability, efficiency, affordability, health, safety and the environment. EPRI members represent 90% of the electric utility revenue in the United States with international participation in 35 countries. EPRI's principal offices and laboratories are located in Palo Alto, Calif.; Charlotte, N.C.; Knoxville, Tenn.; and Lenox, Mass.

Together...Shaping the Future of Electricity

© 2016 Electric Power Research Institute (EPRI), Inc. All rights reserved.  
Electric Power Research Institute, EPRI, and TOGETHER...SHAPING THE  
FUTURE OF ELECTRICITY are registered service marks of the Electric  
Power Research Institute, Inc.

3002008217